

**O‘ZBEKISTON RESPUBLIKASI OLIY VA O‘RTA MAXSUS
TA‘LIM VAZIRLIGI**

**ABU RAYXON NOMLI TOSHKENT DAVLAT TEXNIKA
UNIVERSITETI**

Nizamov O.X.

GIDROTURBINALAR VA GIDROELEKTROSTANSIYALAR

fanidan kurs loyihasini bajarish uchun

USLUBIY KO‘RSATMA

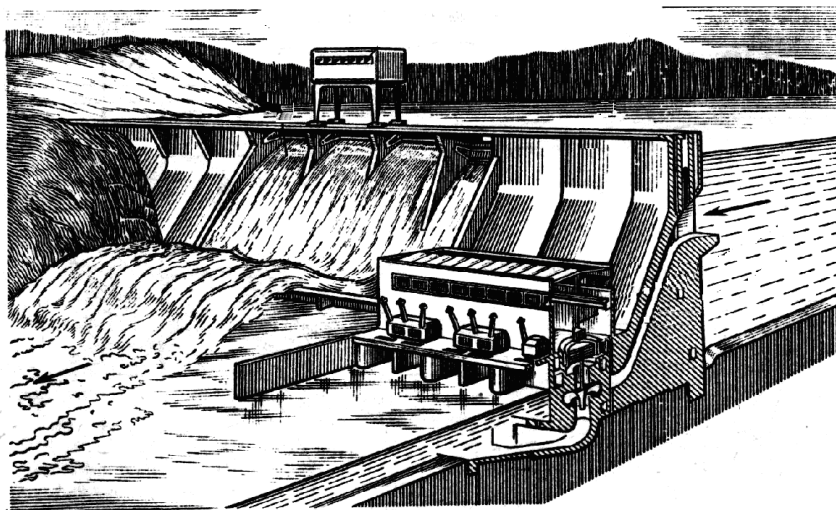

Toshkent- 2015

Mualif: Nizamov O.X.

«Gidroturbinalar va gidroelektrostansiyalar» fanidan kurs loyihasi uslubiy ko'rsatma. Toshkent, ToshDTU, 2015.

Ushbu kurs loyiha ko'rsatmasi 5310100 –Energetika (gidroenergetika) yo'nalishi ta'lim olayotgan bakalavriat talabalariga, shuningdek malakaviy ishni bitiruvchilariga mo'ljallangan bo'lib, davlat standarti asosida tayyorlangan. Unda «Gidroturbinalar va gidroelektrostansiyalar» fanidan olingan nazariy bilimlar asosida amalda gidroelektrostansiyalarni loyihalash uchun kerak bo'ladigan asosiy va yordamchi jihozlarni, ya'ni radial-o'qli va o'qiy turbinalarni, gidrogeneratorlarni hisoblash va tanlash, agregat valini, spiral kamerasini parmetrlarini hisoblash, ishchi va har xil xarakteristikalarini qurish, gidroelektrostansiyalarni loyihalashda mashina zali binosini va agregatni yig'ish maydonchasini tavsiya qilingan o'lchamlar asosida qurish to'g'risida ma'lumotlar berilgan.

Uslubiy ko'rsatmadan 5A310101 – «Gidroelektrostansiyalar va qayta tiklanuvchi energiya manbalari» yo'nalishidagi magistratura mutaxassisligida taxsil olayotgan magistrlar ham foydalanishlari mumkin.

Fanning uslubiy ko'rsatmasi Toshkent davlat texnika universiteti
Ilmiy-metodik kengashini qaroriga binoan nashr qilinmoqda.

Taqrizchilar: Muxammadiev M.M.-ToshDTU «Gidravlika va gidroenergetika» kafedra mudiri, professor, t.f.d.

Fayziev X. -TAQI «Gidrotexnik inshootlar zamini va poydevori» kaf. dotsenti, t.f.n.

© Toshkent davlat texnika universiteti, 2015

MUNDARIJA

KIRISH	4
1 GIDROTURBINA VA GIDROELEKTRO-STANSIYANI LOYIHALASH BOSQICHLARI	6
2 KURS LOYIHASINING TARKIBI VA TUZILISH	7
3 HISOBLAR TARKIBI.....	8
3.1. Gidroturbina parametrlari: H_{\max} , H_{\min} , N , D_1 , Q_1 , n_{si} , η_t , n_s , H_s aniqlash va H_{\max} napor asosida gidroturbina turini tanlash.....	8
3.2. Gidroturbina ekspluatatsiya xarakteristikasini qurish	14
3.3. O'qiy kuchlanishni hisoblash.....	18
3.4. So'rish balandligi H_s ni hisoblash.....	19
3.5. Yo'naltiruvchi apparat kurakchalari ochilish kattaligani hisoblash.....	21
36. Metall spiral kamerani hisoblash.....	22
3.7. Gidroturbina valini hisoblash.....	24
4 Berilgan napor kattaligi bo'yicha gidroelektrstansiya binosi va to'g'on turini tanlash.....	29
5 Gidroturbina suv o'tkazgichini gidravlik hisoblash.....	30
6 So'rish quvurini hisoblash.....	32
7 Hidrogeneratorning asosiy pavrametrlarini aniqlash.....	34
8 GES binosini kompanovka qilish, montaj va ta'mirlash ishlari.....	42
Ilovalar:	
1-ilova	45
2-ilova	48
3-ilova	69
Adabiyotlar	71

KIRISH

Qadimdan odomzod daryolardan energetik man'ba sifatida foydalanishga etibor berib kelgan. Bu energiyadan foydalanish uchun odamlar suv g'ildiraklarini yasashni o'rganishdi, bu g'ildiraklar oqar suv kuchidan foydalanib harakatga keltirilgan.

Bizga yetib kelgan tarixiy hujjatlarga asosan bundan 3000 yil muqaddam madaniyati ilgarilagan Xitoy, Hindiston, Misr, Suriya va Falastinda suv g'ildiraklari sug'orish kanallariga suv ko'tarib berishda va tegirmon toshlarini harakatga keltirishda qo'llanilgan. O'sha zamonlarda shunday ishchi g'ildiroaklarni-charxpalaklarni dehqonchilik rivojlangan boshqa hududlarda, jumladan qadimgi O'zbekistonda ham uchratish mumkin bo'lgan.

Gidroenergoresurslardan foydalanishning yangi imkoniyatlarni yaratishda XIX asrda gidroturbinalar ixtiro qilindi. Elektr moshinalar ixtiro qilinishi va uni uzoq masofalarga uzatish uslublari imkoni yaratilishi bilan gidroelektrostansiyalarda (GES) suv energiyasini elektr energiyasiga aylantirish yo'li o'rganila boshlandi va ular xozirgi kunda rivojlanib ketdi.

GESlarda qo'llaniladigan gidromashinalar turkimiga gidroturbinalar kirib, ular ishlash jarayoniga qarab ikki sinfga bo'linadi:

a) aktiv, unda oqimning faqat kinetik energiya foydalaniladi, suv ishchi g'ildirakka oqim ko'rinishda yuboriladi;

b) reaktiv, kinetik energiyani hamda potensial energiyani boshqa turga aylantiradi, ishchi g'ildirak suyuqlik oqimiga ichida bo'ladi.

Reaktiv turbinalar ishchi g'ildirakdan suv oqimini xarakat qilishiga qarab tizimlarga bo'linadi. Har bir tizim asosiy qo'shimcha ko'rinishlari bilan xarakterlanadi.

Reaktiv turbinalarni asosiy ko'rinishlariga qarab uchta tizimi farqlanadi o'qiy, diagonal va radial-o'qli.

O'qiy turbina tizimi ikkita qo'shimcha ko'rinishi farqlanadi:

a) vertikal propellerli va burama-kurakli;

b) gorizontal kapsulali.

Radial-o'qli tizimining farqlanishi esa quyidagicha:

a) vertikal;

b) gorizontal.

Har bir tizim birnecha tur (seriya) tizimini o'z ichiga oladi, ular suv o'tkazuvchi qismini geometrik o'xshashlik va bir xil nisbiy gidravlik yo'qotish bilan xarakterlanadi.

Aktiv turbinalardan jahon gidroenergetikasida faqat bitta tizim qo'llaniladigan cho'michli turbinalar kiradi.

Gidravlik turbinalarni asosiy elementlariga: ishchi g'ildirak, yo'naltiruvchi apparat, suvni olib keluvchi va olib ketuvchi qurilmalar, ishchi g'ildirak kamerasi, ishchi g'ildirakni generator rotori bilan birlashtiruvchi turbina vali kiradi.

Tanlangan turbina turi va unga xizmat qiluvchi spiral kamera, so'rish quvuri va tok manbasini yaratuvchi gidrogenator hamda hisoblar asosida olingan boshqa jixozlar yordamida GES binosi loyiha qilishda suv tashlagich inshootidan o'tadigan suv sarfiga qarab, stansiya binosining suv osti qismini konstruktiv tuzilishi aniqlanadi.

Stansiya binosini mashina zali, gidroagregatni konstruksiyasi hamda montaj maydonchasi parametrlari asosida quriladi.

GES binosining birdan-bir tabiiy faktorlarining biriga napor va uni hosil qilish usuli kiradi.

Napor hosil qilish bo'yicha GESlar to'g'onli va derevatsiyali bo'ladi. Foydalanadigan naporga qarab to'g'onli gidroelektrstansiyalar quyidagilarga bo'linadi [1]:

- $N \leq 30$ m (ba'zida 40 metrgacha) past naporli bo'lsa, o'zanli GES;

- $N=30-150$ m naporli bo'lsa, to'g'on orti o'rta GES;

- $N > 150$ m bo'lsa, to'g'on orti kata naporli GES bo'ladi.

Derevatsiyali sxemadagi qurilmalarning o'rtacha naporlisini napori 30-300 m.gacha bo'lib, yuqori naporlisini napori 300 metrdan yuqori bo'ladi.

Oxirgi vaqtlarda to'g'onli – derevatsiyali (aralash) sxemalar ishlatilib, daryo o'zani baland to'g'on bilan to'siladi.

GES binosining turi naporni ta'sir qilish xarakteriga qarab quyidagi uchta asosiy turga bo'linadi:

1.To'g'onli sxemaga:

a).O'zanli GES - stansiya binosi to'g'on bilan inshoot tarkibiga kirib, yuqori befdagi suvning gidrostatik ta'siri ostida bo'ladi.

b).Agar stansiya binosi to'g'ondan keyin joylashsa, u to'g'on orti GES deyiladi va suv bosimi ta'sirida bo'lmaydi; suv naporli quvurlar

orqali betonli to'g'onning ichidan yoki ustidan, tuproqli to'g'on bo'lsa, uning ostidan yoki to'g'onni chetlab o'tgan tunnellar orqali keltiriladi.

2. Derevatsiya GES sxemasida to'g'on balandligi uncha katta bo'lmasdan suvni daryodan derevatsiya kanal (tunnel) orqali stansiya binosiga uzatiladi, hosil bo'lgan napor daryo bilan derevatsiya hisobiga bo'ladi.

3. To'g'onli-derevatsiyali sxemada, oldingi ikkita sxemaning qulay hususiyatidan foydalaniladi, ya'ni suv ombori bo'lib, to'g'onning pastki tomonida daryoni og'ishidan hosil bo'lgan suv energiyasidan foydalanish mumkin.

Bu uslubiy ko'rsatmada, talaba gidravlik mashinalarning sinfini va tizimini, gidroelektrostansiyalar turini bilishi va ularni ishlash prinsipi va konstruksiyasi bo'yicha farqlashni, spiral kameralari, so'rish quvurlari va valni parmetrlarini hisoblash, ishchi va turbinaning ekspluatatsiya xarakteristikalarini qurish uslublari bilishi kerak va h.k.

Ushbu kurs loyihasi uslubiy qo'llanmasida, bir-biriga bog'liq bo'lgan kompleks masalalarni yechish, bakalavr-talabalarning o'quv jarayonida olgan nazariy bilimlarini amaliyotda GES binosining loyiha qilishdagi asosiy bosqichlarini o'zlashtirishga tadbiq qilish maqsad qilib qo'yilgan.

«Gidromashinalar va gidroelektrostansiyalar» fani bo'yicha tuzilgan ushbu kurs loyihasining uslubiy qo'llanmasi, davlat standartiga mos ravishda 5310100 –Energetika (gidroenergetika) yo'nalishi ta'lim olayotgan bakalavrlarni tayyorlash uchun tuzilgan.

1. GIDROTURBINA VA GIDROELEKTROSTANSIYANI LOYIHALASH BOSQICHLARI

- 1).Gidroturbina parametrlarini: H_{\max} , H_{\min} , N , D_1 , Q'_1 , n_{si} , η_t , n_s , H_s aniqlash va H_{\max} napor asosida gidroturbina turini tanlash .
- 2).Gidroturbina ekspluatatsiya xarakteristikasini qurish.
- 3).O'qiy kuchlanishni hisoblash
- 4). So'rish balandligi H_s ni hisoblash
- 5).Yo'naltiruvchi apparat kurakchalari ochilish kattaligani hisoblash.
- 6).Metall spiral kamerani hisoblash
- 7).Gidroturbina valini hisoblash
- 8).Berilgan napor asosida gidroelektrostansiya binosi va to'g'on

- turini tanlash;
- 9).Gidroturbina suv o'tkazgichini hisoblash;
 - 10).So'rish quvurini hisoblash,
 - 11).Gidrogeneratorning asosiy parametrlari:
 - a). Zontli tipdagi gidrogeneratorning asosiy o'lchamlarni hisoblash.
 - b). Osma gidrogeneratorning asosiy o'lchamlarini hisoblash.
 - 12)O'rnatilgan ishchi –g'ildirak balandlik belgisini aniqlash
 - 13)GES binosini kompanovkasi, montaj va ta'mirlash ishlari.

2.KURS LOYIHASINING TARKIBI VA TUZILISHI

Kurs loyihasi tushintirish xatidan tashkil topib, u quyidagilarni o'z ichiga oladi::

- titul varag'i;
- mundarija
- kirish so'zi;
- kurs loyihani bajarish uchun topshiriq (variant asosida);
- tekst qismi;
- ilovalar;
- foydangan adabiyotlar ro'yxati;

Kurs loyahasining hisoblash-yozuv qismi

- Umumiy qism,
- Hisobiy kism,
- Xulosa.

Loyihaning tushintirish xati va grafik-hisoblash qismi yuqorida ko'rsatilgan tartibda A-4 formatli oq qozg'ozda sharikli ruchka bilan rasmiylatiriladi yoki kompyutorda bajariladi.

Gidroenergetik inshootini loyihalash murakkabligiga qarab rahbar tomonidan tekst qismini hajmi belgilanadi.

Tushintirish xatini tuzilishi

Kurs loyahasini tushintirish xatida, tanlab olingan variantni hisoblar va xullosalar bilan kerakli asoslab, foydalanilgan

adabiyotlarni ko'rsatish talab qilinadi.

Grafik qismini tuzilishi

A-4 formatli millimetr qog'ozda esa spiral kamera, H_{max}, H_{min} va H_h naporlarga bog'liq bo'lgan $\eta=f(N), N=f(Q'_1), \eta=f(H), a_o=f(N), H_s=f(N)$ va $\sigma=f(N)$ xarakteristikalar hamda $N=f(N)$ ekspluatatsiya xarakteristikasi qalamda yoki kompyutorda bajariladi.

GES binosini chizmasi A-1 formatli vatmanga (yoki millimetr qog'ozga) uchta proeksiyada bajariladi, ya'ni vertikal, gorizonta va profil ko'rinishda, A-4 formatda esa millimetr qog'ozga: generator, so'rish quvuri va yuk ko'taruvchi-tashuvchi mexanizmni qalamda yoki kompyutorda bajariladi. Chizma ustidagi yozuvlar standart chizma hariflar bilan bajariladi.

3.HISOBLAR TARTIBI

3.1. Gidroturbina parametrlarini: $H_{max}, H_{min}, N, D_1, Q'_1, n_{si}, \eta_t, n_s, H_s$ aniqlash va H_{max} napor asosida gidroturbina turini tanlash.

Har bir talaba 1-jadvalning variantlari asosida H_{max}, H_{min} , bo'yicha gidroturbinaning turi, quvvati va boshqa kattaliklarni aniqlaydi.

1) Gidroturbina turini tanlash uchun quyidagi H_{max}, H_{min} , parametrlar aniqlanadi:

$$H_{max} = \nabla YUB_{max} - \nabla PB_{max} - h_w ;$$

$$H_{min} = \nabla YUB_{min} - \nabla PB_{max} - h_w.$$

1-jadval

Variantlar	$\nabla YUB_{max}, m$	$\nabla YUB_{min}, m$	$\nabla PB_{min}, m$	H_h, m	$\nabla PB_{max}, m$	h_w, m	$\nabla PB, m$	$Q_s, m^3/s$	L, M
1	580	575	505	70	511	0.6	495	40	80
2	608	600	500	102	504	1.0	493	50	120
3	460	452	420	33	424	0.5	412	45	45
4	590	583	547	37	550	0.8	542	50	50
5	720	714	695	20	698	0.5	688	30	25
6	830	826	770	54	778	0.7	820	50	65
7	350	347	238	105	247	1.2	233	70	120
8	540	534	491	44	497	0.4	485	40	55

1-jadval davomi

9	960	955	855	100	865	1.1	850	65	115
10	840	836	775	61	780	0.6	769	50	72
11	750	744	687	57	694	0.6	680	45	65
12	770	766	703	63	710	0.7	695	55	73
13	490	484	386	98	396	1.0	379	65	113
14	560	550	532	24	530	0.4	525	50	32
15	670	666	601	63	608	0.6	595	45	74
16	700	694	636	58	642	0.5	630	50	68
17	1000	996	845	148	856	1.3	838	60	160
18	1100	1093	992	104	996	1.0	985	70	120
19	950	945	910	35	915	0.5	902	40	45
20	1050	1046	982	63	988	0.6	975	55	72
21	1200	1193	1130	65	1136	0.7	1123	52	75
22	1250	1245	1212	33	1220	0.4	1206	35	43
23	1300	1293	1110	184	1115	1.4	1104	74	215
24	1350	1343	1314	32	1319	0.4	1307	25	42
25	1240	1230	1208	28	1210	0.4	1201	25	36
26	1150	1143	1050	94	1053	0.9	1043	64	112
27	920	924	902	15	906	0.4	895	30	-
28	830	824	786	39	792	0.5	778	35	48
29	710	705	669	37	673	0.5	661	35	46
30	820	818	794	22	800	0.4	788	25	27
31	580	575	503	70	513	0.6	420	45	85
32	608	600	500	102	504	1.0	560	53	117
33	460	455	417	39	420	0.5	355	48	48
34	590	583	547	37	553	0.8	500	57	45
35	720	714	610	105	614	1,2	700	78	120
36	830	826	770	54	778	0.7	720	54	64
37	350	347	238	105	247	1.2	210	76	122
38	540	534	491	44	497	0.4	430	48	53
39	960	955	855	100	865	1.1	850	67	120
40	840	836	775	61	780	0.6	582	56	70
41	750	744	687	57	694	0.6	590	48	65
42	770	766	703	63	710	0.7	650	58	70
43	490	484	386	98	396	1.0	380	69	108
44	580	570	523	53	522	0.4	500	59	62
45	670	666	601	63	608	0.6	590	49	71
46	700	694	636	58	642	0.5	580	55	67
47	1000	994	836	158	846	1.2	800	67	170
48	1100	1093	992	104	996	1.0	880	75	121
49	950	945	907	39	909	0.5	890	49	48
50	1050	1046	982	63	988	0.6	900	65	71
51	1200	1193	1130	65	1136	0.7	1000	58	73
52	1250	1245	1082	163	1086	1,2	1100	69	173
53	1300	1293	1110	184	1115	1.4	1100	84	205

54	1350	1343	1312	40	1307	0.4	1200	66	50
55	1240	1230	1167	68	1166	0.5	1090	56	78
56	1150	1143	1050	94	1053	0.9	900	67	104
57	920	924	848	65	864	0.4	800	60	74
58	830	824	786	39	792	0.5	710	57	48
59	710	705	669	37	673	0.5	660	78	43
60	820	818	750	66	756	0.4	580	65	74

Radial- o'qli gidroturbinaning ishchi g'ildiragi asosiy gidravlik ko'rsatkichi va konstruktiv parametrlari

2-jadval

Parametrlar	Ishchi g'ildirak								
	RO' 45	RO' 75	RO' 115	RO' 170	RO' 230	RO' 310	RO' 400	RO' 500	
Yo'naltiruvchi apparatning balandligi $\underline{b}=b_o/D_1$	0,35	0,30	0,25	0,20	0,16	0,12	0,1	0,08	
H_{max}, H_{min} naporlar chegarasi, m	30-45	40-75	70-115	110-170	160-230	220-310	290-400	380-500	
Q^1_{lmax} , keltirilgan suv sarfi, l/s	1400-1370	1370-1250	1250-1030	1030-650	650-420	420-280	280-200	200-150	
Keltirilgan ayl. soni, n^1_{lop} n^1_{this} , ayl/min	78 78	73 77	70 74	68 71	65 68	60 65	58 62	58 59.5	
Kavitatsiya koef-fitsienti, σ	0,27-0,23	0,243-0,16	0,168-0,097	0,1-0,06	0,065-0,047	0,048-0,04	0,042-0,035	0,036-0,03	

2). H_{max} naporga asosan 2 va 3 – jadval orqali gidrotur-bina turi tanlanadi va bosh universal xarakteristikasi (BUXi 2-ilovadan) olinadi [2].

3). Hisobiy napor asosida gidroturbinaning taxminiy quvvati N hisoblanadi:

$$N=9.81QH\eta_m, \text{ kVt}$$

bu erda η_i gidroturbananing bosh universal xarakteristikasidan olinadi.

4). Ishchi g'ildirak diametri quyidagi formuladan aniqlanadi:

$$D_1 = \sqrt{\frac{N}{9,81Q^1 H_h \sqrt{H_h \eta_m}}}, \text{ m};$$

Topilgan diametrga yaqin bo'lgan standart D_{1st} diametr kattaligini 4-jadvaldan olamiz, sm.

Burama kurakli gidroturbinaning ishchi g'ildiragi asosiy gidravlik ko'rsatkichi va konstruktiv parametrlari

3-jadval

Parametrlar	Ishchi g'ildirak								
	BK-10	BK-15	BK-20	BK-30	BK-40	BK-50	BK-60	BK-70	BK-80
Yo'naltiruvchi apparatning balandligi $b=b_0/D_1$	0,33	0,35	0,37	0,41	0,43-0,45	0,47-0,49	0,51-0,54	0,57	0,6
H_{max}, H_{min} naporlar chegarasi,	2-10	5-15	10-20	15-30	20-40	30-50	40-60	45-70	50-80
Q^1_{lmax} , keltirilgan suv sarfi, l/s	2250	2130	2040	1940	1880	1810	1690	1600	1520
Keltirilgan ayl. soni, n^1_{lop} , n^1_{this} , ayl/min	165 200	150 180	138 160	125 140	115 130	106 120	100 110	100 110	100 110
Z_1 - ishchi g'ildirak kuraklar soni	4	4	4	4	5	6	7	8	8
Kavitatsiya koef. σ	1,4	1,0-0,84	0,835-0,68	0,745-0,505	0,68-0,4	0,505-0,325	0,4-0,27	0,36-0,23	0,325-0,205

4- jadval

D_1 diametrni normal qatori, sm						
180	200	225	250	280	320	360
400	450	500	550	600	650	700
750	800	850	900	950	1000	1050

5) Standart diametr bo'yicha keltirilgan suv sarfi Q^1 ni tekshiramiz

$$Q^1_1 = \frac{N}{9.81 D^2_{1st} H_h \sqrt{H \eta_m}}, \text{ m}^3/\text{s};$$

6) Quyidagi formula orqali gidroturbinaning f.i.k. aniqlanadi:

$$\eta_{TMAX} = 1 - (1 - \eta_{MMAX}) \left(0,25 + 0,75 \sqrt[5]{\frac{Re_M}{Re_T}}\right)$$

bu yerda η_{MMAX} gidroturbinani bosh universal xarakteristikasi (BUX) dan aniqlanadi, unda quyidagi ko'rsatkichni $\sqrt[5]{\frac{Re_M}{Re_T}}$ aniqlash uchun

quyidagi tenglamadan $\frac{Re_M}{Re_T} = \frac{D_{1M} \sqrt{H_M}}{D_{1CT} \sqrt{H_h}}$ yechiladi va topilgan

kattalik bo'yicha 1-rasmdan [2] $\sqrt[5]{\frac{Re_M}{Re_T}}$ qiymati topiladi; bu erda

D_{1M} va H_M -gidroturbina modelining diametri - 0.46 m va napori - 4 m ; H_h -haqiqiy turbinaning hisobiy napori

7) Topilgan η_{TMAX} orqali gidroturbinani haqiqiy quvvati

aniqlanadi $N = 9.81QH\eta_{TMAX}$, kVt

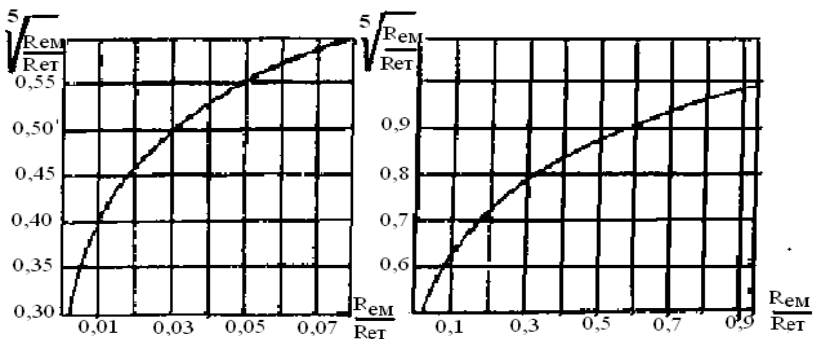

1-rasm. $\sqrt[5]{\frac{Re_M}{Re_T}}$ bog'liklik grafigi

8) Normal aylanishlar soni aniqlash uchun aylanishlar sonini tuzatish koeffitsienti topiladi:

$$\Delta n_1^1 = n_{1.m.op}^1 \left(\sqrt[5]{\frac{\eta_{TMAX}}{\eta_{MMAX}}} - 1 \right)$$

Bu formuladagi $\eta_{T.MAX}$ haqiqiy turbina f.i.k., $\eta_{M.MAX}$ -turbina modeli

f.i.k., $n_{M.OP}$ -optimal keltirilgan aylanish soni esa 2 yoki 3 –jadvaldan aniqlanadi.

Tuzatish koeffitsienti turbinaning hamma ishlash rejimi uchun bir xil qabul qilinadi, ya'ni n_1^1 va Q_1^1 kooordinatalardagi jarakteristikalarning hamma nuqtalari uchun bir xil bo'ladi.

Har doim $n_{1T}^1 > n_{1M.OII}^1$;

yoki $n_{1T}^1 = n_{1M.OII}^1 + \Delta n_1^1$ bo'ladi va oxirgi tenglikdan n_{1T}^1 ni topib, quyidagi tenglamaga qo'yib gidroagregatni normal aylanish sonini aniqlaymiz:

$$n = \frac{n_{1T}^1 \sqrt{H_h}}{D_{1cm}}, \text{ ayl/min};$$

Topilgan aylanishlar soni n ga yaqin bo'lgan 5 jadval asosida gidrogeneratorni sinxron aylanish soni n_{si} bilan almashtiramiz

Gidroturbinaning sinxron n_{si} aylanish soni tezligi

5 -jadval

Rotorning juft qu-vubllari	Sinxron aylanishlar tezligi, ayl/min	Rotorning juft quvtubla-ri	Sinxron aylanishlar tezligi, ayl/min	Rotorning juft qu-tublari	Sinxron aylanishlar tezligi, ayl/min
12	500	48	125	88	68,2
14	428,6	52	115,4	90	66,7
16	375	56	107,1	92	65,2
18	333,3	60	100	96	62,5
20	300	64	93,8	100	60
24	250	66	90,9	102	58,8
26	230,8	68	88,2	104	57,4
28	214,3	70	85,7	108	55,6
30	200	72	83,3	110	54,6
32	187,5	76	78,9	112	53,6
36	166,7	78	76,9	114	52,6
40	150	80	75	116	51,8
44	136,4	84	71,4	120	50

a) sinxron aylanishlar soni orqali hisobiy napor uchun aylanishlar sonini tekshiramiz:

$$n_1^1 = \frac{n_{SI} D_{1ST}}{\sqrt{H_h}} - \Delta n_1^1 ; \quad \text{ayl/ min}$$

b) D_{1ST} va n_{SI} larni to'g'ri topilganini N_{MAX} va N_{MIN} larning keltirilgan aylanishlar soni orqali tekshiramiz:

$$n_{1MAX}^1 = \frac{n_{SI} D_{1ST}}{\sqrt{H_{min}}} - \Delta n_1^1 ; \quad \text{ayl./ min}$$

$$n_{1min}^1 = \frac{n_{SI} D_{1ST}}{\sqrt{H_{max}}} - \Delta n_1^1, \quad \text{ayl./ min}$$

9) Gidroturbinaning so'rish balandligi balandligini aniqlanadi

$$H_S = 10 - \frac{\nabla}{900} - k_\sigma \sigma H_h$$

Aniqlangan so'rish balandligi qiymati orqali gidroturbina o'qining ∇PB ga nisbatan joylashishi topiladi.

3.2. Gidroturbina ekspluatatsiya xarakteristikasini qurish

Ekspluatatsiya vaqtida gidroturbina ishchi rejimi har xil bo'ladi. H va N o'zgarish bilan Q_i^1, η va kavitatsiya koeffitsienti σ co'rish balandligi H_S ham o'zgaradi va bir xil aylanishlar sonini ushlab turishga xarakat qilinadi. Gidroturbinani to'g'ri ekspluatatsiya qilish uchun yuqorida keltirilgan kattaliklar orasidagi bog'lanishni bilish kerak. Shu maqsadda aniqlangan n_{SI}, D_{1st} lar orqali ekspluatatsiya xarakteristikasi quriladi. Har xil H_{max}, H_h, H_{min} naporlar uchun BUXga aniqlangan $n_{li}^1 = const$ kattaliklar bo'yicha Q_{li}^1 o'qiga parallel chiziqlar o'tkazilib $\eta = const$ ($\varphi = const$) egri chiziq bilan kesishgan nuqtalarda η va Q_{li}^1 qiymatlar olinadi va gidroturbina foydali ish koeffitsienti chiziqlarini qurish uchun hisobiy ishlar jadval asosida olib boriladi.

6 – jadval

RO' turbina ishchi g'ildiragi kattaliklari: $D_{1st} = \dots, m$; $n_{si} = \dots, \text{ayl/min}$; $H_{\max} = \dots, m$; $\Delta\eta = \eta_{T.MAX} - \eta_{M.MAX} = \dots, \%$;					
№ K-k	$\eta_{mi},$ %	$Q_{li}^1,$ m^3/s	$\eta_{Ti} = \eta_{Mi} + \Delta\eta$	N_i, kVt	Ilova
1					$H_{\max} \sqrt{I_{i\Delta\delta}} = \dots, m$; $n_{1,min}^1 = \dots, \text{ayl/min}$ $N_i = 9.81 \cdot Q_{li}^1 \cdot D_{1CT}^2 \cdot$ $H_{\max} \sqrt{I_{i\Delta\delta}} \cdot \eta_{Ti} =$ $= A \cdot Q_{li}^1 \cdot \eta_{Ti} = \dots, \text{kVt}$
2					
3					
...					

7 – jadval

RO' turbina ishchi g'ildiragi kattaliklari: $D_{1st} = \dots, m$; $H_h = \dots, m$; $n_{si} = \dots, \text{ayl/min}$; $\Delta\eta = \eta_{T.MAX} - \eta_{M.MAX} = \dots, \%$;					
K-k №	$\eta_{mi},$ %	$Q_{li}^1,$ $m^3/s,$	$\eta_{Ti} = \eta_{Mi} + \Delta\eta$	$N_i = \dots, \text{kVt}$	Ilova
1					$H_h \sqrt{I_h} = \dots, m$; $n_1^1 = \dots, \text{ayl/min}$; $N_i = 9.81 \cdot Q_{li}^1 \cdot D_{1CT}^2 \cdot$ $H_h \sqrt{I_h} \cdot \eta_{Ti} =$ $= A \cdot Q_{li}^1 \cdot \eta_{Ti} = \dots, \text{kVt}$
2					
3					
...					

8-jadval

RO' turbina ishchi g'ildiragi kattaliklari: $D_{1st} = \dots, m$; $H_{min} = \dots, m$; $n_{si} = \dots, ayl/min$; $\Delta\eta = \eta_{T.MAX} - \eta_{M.MAX} = \dots, \%$;					
K-k №	η_{mi} , %	Q_{li}^1 , m^3/s	$\eta_{Ti} = \eta_{Mi} + \Delta\eta$	N_i , kVt	Ilova
1					$H_{min} \sqrt{I_{min}} = \dots, m$; $n_{1MAX}^1 = \dots$ ayl/min; $N_i = 9.81 \cdot Q_{li}^1 \cdot D_{1CT}^2 \cdot H_{min}$ $\sqrt{I_{min}} \cdot \eta_{Ti} = A \cdot Q_{li}^1 \cdot \eta_{Ti} = \dots, kVt$
2					
3					
...					

9-jadval

BK turbina ishchi g'ildiragi kattaliklari: $D_{1st} = \dots, m$; $H_{max} = \dots, m$; $n_{si} = \dots, ayl/min$; $\Delta\eta = \eta_{T.MAX} - \eta_{M.MAX} = \dots, \%$;						
K-k №	φ_{ib} , %	η_{mi} , %	Q_{li}^1 , m^3/s	$\eta_{Ti} = \eta_{Mi} + \Delta\eta$	N_i , kVt	Ilova
1						$H_{max} \sqrt{H_{max}} = \dots, m$; $n_{1Min}^1 = \dots, ayl/min$; $N = 9.81 \cdot Q_{li}^1 \cdot D_{1CT}^2 \cdot H_{max}$ $\sqrt{H_{max}} \cdot \eta_{Ti} = A \cdot Q_{li}^1 \cdot \eta_{Ti} = \dots, kVt$
2						
3						
...						

10-jadval

BK turbina ishchi g'ildiragi kattaliklari: $D_{1st} = \dots, m$; $n_{si} = \dots, \text{ayl/min}$; $H_h = \dots, m$; $\Delta\eta = \eta_{T.MAX} - \eta_{M.MAX} = \dots, \%$						
K-k №	$\varphi_i, \%$	$\eta_{mi}, \%$	$Q_{li}^1, m^3/s$	$\eta_{Ti} = \eta_{Mi} + \Delta\eta$	N, kVt	Ilova
1						$H_h \sqrt{I_h} = \dots, m$; $n_1^1 = \dots, \text{ayl/min}$;
2						$N = 9.81 \cdot Q_{li}^1 \cdot D_{ICT}^2$
3						$H_h \sqrt{I_h} \eta_T =$ $= A \cdot Q_{li}^1 \cdot \eta_{Ti} = \dots, \text{kVt}$
...						

11-jadval

BK turbina ishchi g'ildiragi kattaliklari: $D_{1st} = \dots, m$; $n_{si} = \dots, \text{ayl/min}$; $H_{min} = \dots, m$; $\Delta\eta = \eta_{T.MAX} - \eta_{M.MAX} = \dots, \%$						
K-k №	$\varphi_i, \%$	$\eta_{mi}, \%$	$Q_{li}^1, m^3/s$	$\eta_{Ti} = \eta_{Mi} + \Delta\eta$	N _i , kVt	Ilova
1						$H_{min} \sqrt{H_{min}} = \dots, m$;
2						$n_{1MAX}^1 = \dots, \text{ayl/min}$; $N = 9.81 \cdot Q_{li}^1 \cdot D_{ICT}^2 *$
3						$H_{min} \sqrt{H_{min}} \cdot \eta_{Ti} =$ $= A \cdot Q_{li}^1 \cdot \eta_{Ti} = \dots, \text{kVt}$
...						

6,7,8-jadvallarda H_{max}, H_h, H_{min} - naporlar uchun aniqlangan η_T va N qiymatlari orqali radial o'qli turbinaning $\eta_T = f(N)$ xarakteristikasi va $N = f(Q^1_i)$, $\eta_{max} = f(N_i)$ yordamchi grafiklari quriladi (1-ilova; 1,2,3 - rasmlar); 9,10,11 – jadvallar qiymatlari orqali ham burama kurakli turbinani radial o'qnikiga o'xshash grafiklari quriladi

3.3.O'qiy kuchlanishni hisoblash

Gidroturbina valini va vertikal gidroagregatini ushlab turuvchi podpyatnikni hisoblashda va loyihalashda o'qiy yo'nalishda ta'sir qilayotgan $P_{o'q}$ kuchlanishni aniqlash quyidagacha bajariladi.

$$P_{o'q} = P_{o'q,g} + 1,1 (G_{ig'} + G_{tv} + G_{gr} + G_{rv}), \text{ kN}$$

bu yerda $R_{o'q}$ - o'qiy yo'nalishdagi kuchlanishni gidravlik tashkil etuvchisi

$$P_{o'q,g} = K_{o'q} \cdot D_{1st}^2 \cdot H_{max} = \dots\dots\dots, \text{ kNm.}$$

bu yerda $K_{o'q}$ - RO' yoki BK gidroturbina uchun 5- jadvaldan olinadi, kN/m^2 .

$$G_{ig'} = K \cdot D_{1st}^3 = \dots\dots\dots, \text{ kN.},$$

bu yerda K- koefitsient 12-jadvaldan olinadi, kNm

$K_{O'Q}$ – turbina sinfi va ishchi g'ildirak turiga qarab taxminan aniqlovchi o'qiy koefitsient

12-jadval

BK gidrotur- binalar	Ishch g'ildirak turi uchun $K_{o'q}$ qiymati					
	BK 15., BK 20		BK 30		BK 40	BK 80
	6,5		6,9		7,2	
RO' gidrotur- binalar	Ishch g'ildirak turi uchun $K_{o'q}$ qiymati					
	RO' 45	RO' 75	RO' 115	RO' 170	RO' 230	RO' 310
	4,1.	3,4	2,8	2,6	1,4	1,2

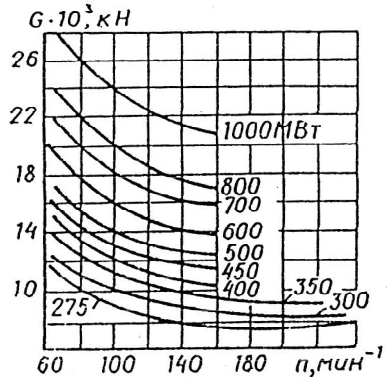
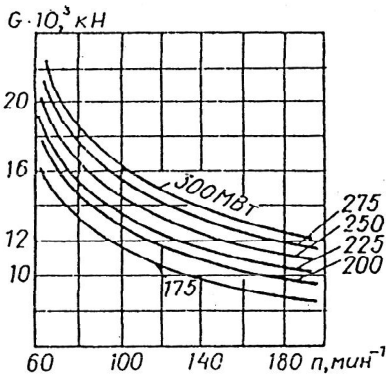

2-rasm. Generator rotori va vali og'irligini rotor aylanishlar soniga qarab aniqlash

Gidroturbina vali og'irligi

$$G_{tv}=(0,6-1,3)G_{ig'} = \dots, \text{ kN.}$$

Generator rotorini va valini og'irligi uning umumiy og'irligi G ning 0,5 - 0,55 qismini tashkil qiladi. U, 2 - rasmdan generator quvvati va rotorning aylanishi soniga qarab tanlanadi.

$$G_{gr} + G_{rv} = \dots, \text{ kN.}$$

To'liq o'qiy kuchlanish hisoblanadi:

$$P_{o'q} = P_{o'q,g} + 1,1 (G_{ig'} + G_{tv} + G_{gr} + G_{rv}) = \dots, \text{ kN.}$$

3.4. So'rish balandligi H_s ni hisoblash

Bosh universal xarakteristika (BUX) da keltirilgan ma'lum n_1^1, Q_1^1 va σ kattaliklar orqali quyidagi formuladan so'rish H_s balandligini aniqlaymiz.

$$H_s = 10 - \frac{\nabla}{900} - K_\sigma \cdot \sigma \cdot H$$

bu yerda ∇ - stansiya binosining dengaz satxiga nisbatan joylashish balandligi, m.

K_σ - kavitatsiya koeffitsienti σ ni zaxirasi bo'lib uning qiymati $K_\sigma = 1,05-1,1$ ga teng bo'ladi.

σ - kavitatsiya koeffitsienti hisoblar uchun BUXdan olinadi

$$(\sigma = \sigma_t)$$

$$\frac{D_a}{\rho g} = 10,2 - 10,3; \quad 10 = \frac{D_a - D_a}{\rho g} \quad \text{dengaz satxidagi atmosfera}$$

bosimi.

$$\frac{P_a}{\rho g} \quad 0,2 \div 0,3 - (288 \div 298) \hat{E} \quad \text{haroratda yuzaga keladigan bug'}$$

bosimi.

So'rish balandligini hisoblashni jadval usulida olib boramiz. Buning uchun BUXda har xil H_{max}, H_h, H_{min} naporlar uchun topilgan $n_{1i}^1 = const$ kattaligi bo'yicha Q_1^1 o'qiga parallel chiziqlar o'tkazilib $\sigma = const$ egri chiziqlar bilan kesishgan nuqtalarda σ va Q_1^1 qiymatlar olinadi va H_{max}, H_h, H_{min} naporlar uchun so'rish balandligi H_s ni aniqlash hisoblari quyidagi jadvallarda kiritiladi (13,14, va 15 - jadvallar). Hisoblarda $\eta_{T,MAX}$ o'zgarmas bo'ladi.

13 – jadval

T/r	σ_i	$K_\sigma \sigma_i H_{\max}$	H_{SI}, m	$Q_{li}^1, m^3/s$	N_b, kVt	Ilova
1.						$\nabla = \dots, m;$ $H_{\max} = \dots, m;$
2.						$n'_{\min} = \dots, ayl/min;$
3.						$N_i = 9.81 \cdot Q_{li}^1 \cdot D^2_{ICT} \cdot *$ $H_{\max} \sqrt{H_{\max}} \cdot \eta_{T,MAX} =$
....						$= A \cdot Q_{li}^1 = \dots, kVt;$ $\eta_{T,MAX} = \dots,$

14 – jadval

T/r	σ_i	$K_\sigma \sigma_i H_h$	H_{SI}, m	$Q_{li}^1, m^3/s$	N_b, kVt	Ilova
1.						$\nabla = \dots, m;$ $H_h = \dots, m;$
2.						$n'_1 = \dots, ayl/min;$
3.						$N = 9.81 \cdot Q_{li}^1 \cdot D^2_{ICT} \cdot *$ $H_h \sqrt{H_h} \cdot \eta_{T,MAX} =$
....						$= A \cdot Q_{li}^1 = \dots, kVt;$ $\eta_{T,MAX} = \dots,$

15-jadval

T/r	σ_i	$K_\sigma \sigma_i H_{\min}$	H_{SI}, m	$Q_{li}^1, m^3/s$	N_b, kVt	Ilova
1.						$\nabla = \dots, m; H_{\min} = \dots, m;$ $n'_{1\max} = \dots, ayl/min$
2.						$N = 9.81 \cdot Q_{li}^1 \cdot D^2_{ICT}$
3.						$* H_{\min} \sqrt{H_{\min}} \cdot \eta_{T,MAX} =$
....						$= A \cdot Q_{li}^1 = \dots, kVt$ $\eta_{T,MAX} = \dots,$

13,14 ,15- jadvallarda berilgan kattaliklar asosida H_i -naporlar

uchun yordamchi $H_s = f(N)$, $\sigma = f(N)$ grafiklari quriladi. (1-ilova: 4,5, 6- rasmlar)

3.5.Yo‘naltiruvchi apparat kurakchalari ochilish kattaligani hisoblash

Yo‘naltiruvchi apparat kurakchalari ochilish kattaligini quyidagi formula bo‘yicha xisoblanadi:

$$a_o = a_{om} \cdot D_1 / D_{1m} \cdot Z_{om} / Z_o$$

bu yerda a_{om} va a_o turbina modeli va haqiqiysining yo‘naltiruvchi apparat kurakchalarini ochilish kattaligi, mm.,

D_{1m} va D_1 - turbina modeli va haqiqiysining ishchi g‘ildiraklari diametrlari, mm.,

Z_{om} va Z_o turbina modeli va haqiqiysining yo‘naltiruvchi apparat kurakchalari sonlari ($Z_{om} = Z_o$).

Bosh universal xarakteristikada $a_{om} = const$ chiziqlarini $n'_{li} = const$ chiziqlari bilan kesishgan nuqtalariga to‘g‘ri kelgan Q'_1 kattaliklar aniqlanadi va hisob jadval asosida olib boriladi.

16-jadval

$H_{max} = \dots, m; \quad n'_{lmin} = \dots, ayl/min, \quad \eta_{T.MAX} = \dots, \%$					
T/r	a_{om}	a_{ot}	Q'_{li}	N	Ilova
	mm	mm	m ³ /s	kVt	
1.					$a_o = a_{om} \cdot D_1 / D_{1m} =$ $N = 9.81 \cdot Q'_{li} \cdot D^2_{ICT} \cdot H_{max} \sqrt{H_{max}}$ $\eta_{T.MAX} = A \cdot Q'_{li} = \dots, kVt;$
2.					
3.					
...					

17-jadval

$H_h = \dots, m; \quad n'_l = \dots, \text{ayl/min}, \quad \eta_{T,MAX} = \dots, \%$					
T/r	a_{om}	a_{ot}	Q_{li}^1	N	Ilova
	mm	mm	m^3/s	kVt	
1.					$a_o = a_{om} \cdot D_l / D_{lm} =$ $N = 9.81 \cdot Q_{li}^1 \cdot D_{ICT}^2 \cdot$ $\cdot H_h \sqrt{H_h} \cdot \eta_{T,MAX} =$ $= A \cdot Q_{li}^1 = \dots, kVt;$
2.					
3.					
...					

18-jadval

$H_{min} = \dots, m; \quad n'_{lmax} = \dots, \text{ayl/min}, \quad \eta_{T,MAX} = \dots, \%$					
T/r	a_{om}	a_{ot}	Q_{li}^1	N	Ilova
	mm	mm	m^3/s	kVt	
1.					$a_o = a_{om} \cdot D_l / D_{lm} =$ $N = 9.81 \cdot Q_{li}^1 \cdot D_{ICT}^2 \cdot H_{min} \sqrt{H_{min}} \cdot$ $\cdot \eta_{T,MAX} =$ $= A \cdot Q_{li}^1 = \dots, kVt$
2.					
3.					
...					

16,17,18 - jadvallarda H_i -naporlar uchun aniqlangan haqiqiy turbina yo'naltiruvchi apparat kurakchalari ochilish kattaligi a_0 uchun yordamchi $a_0 = f(N)$ egri chiziqlari quriladi (1-ilova : 6-rasm)

3.6. Metall spiral kamerani hisoblash

1. Spiral kamerani o'rab olish burchagini $\varphi = 345^\circ$ olamiz va D_{ICT} diametr va xisobiy napor uchun quyidagilarni $D_a = \dots, mm, D_b = \dots, mm,$ 19-jadvalidan aniqlaymiz

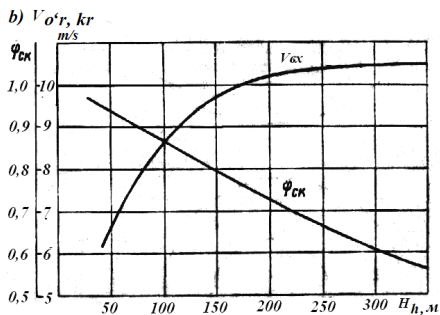
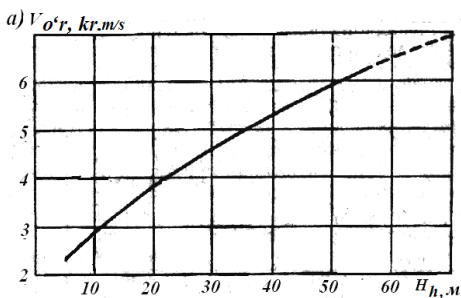

3-rasm. Spiral kameralarning kirish kesimidagi v_{kr} tezligi: a – betonli va b - metalli spiral kameralar uchun; φ_{sk} – kirishdagi tezlik koeffitsienti

2. Hisobiy napor H_h asosida kirishdagi tezlikni ($V_{kr} = \dots$, m/s) 3 - rasmdan aniqlaymiz.

3.Spiral kamera ga kirishdagi Q_{kr} suv sarfi quyidagi formuladan aniqlanadi:

$$Q_{kr} = \frac{Q \cdot \varphi}{360^\circ} = \dots, \text{M}^3 / \text{s}$$

Betonli va metalli spiral kameralarning standart o'lchamlar D_0, D_a, D_b
19-jadval

Ishli g'ildirak diametri, mm	Diametrlar, mm		Betonli spiral kamera								Metalli spiral kamera				
			D_a		D_b										
			$H < 40 \text{ M}$	$H = 40-80 \text{ M}$	$H < 170 \text{ M}$	$H = 170 \text{ M}$	$H < 75 \text{ M}$	$H = 75-115 \text{ M}$	$H = 115-170 \text{ M}$	$H = 170-230 \text{ M}$					
1	2	3	4	5	6	7	8	9	10	11					
1800	220	2430	-	2850	-	2600	-	-	-	-	3200				
2000	2400	2700	-	3130	2850	2850	3400	3400	3400	3400	3500				
2500	2900	3400	-	4000	3400	3550	4050	4100	4100	4100	4350				
2800	3250	3850	4450	4500	3850	3950	4600	4600	4600	4650	4850				
3200	3750	4250	4900	4950	4300	4450	5100	5150	5200	5200	5400				
3600	4200	4800	5500	5550	4800	4950	5700	5750	5800	5800	6000				
4000	4800	5400	6200	6250	5300	5500	6250	6300	6350	6350	6650				
4500	5250	6000	6900	6950	6000	6150	7100	7150	7200	7200	7450				
5000	6000	6600	7550	7600	6600	6850	7750	7800	7850	7850	8200				
5500	6720	7400	8200	8600	7400	7650	8650	8750	8800	8800	9150				
6500	8040	8850	10000	10150	8850	9150	10350	110450	9550	9850	9850				
7000	8520	9400	10800	10950	9400	9700	11000	11100	10550	11000	11000				
7500	9000	10000	11400	11500	10000	-	11700	11800	11200	11650	-				
8000	9600	10400	11900	12000	10400	-	12150	12250	-	-	-				
8500	10200	11050	12600	12700	11050	-	11900	13000	-	-	-				
9000	10800	11800	13500	13600	11800	-	13800	13900	-	-	-				
9600	11400	12350	14100	-	12350	-	14450	14550	-	-	-				
10000	12000	12900	14700	-	12900	-	15000	15100	-	-	-				

4. Spiralar kameraga kirish qirqim radiusi quyidagicha aniqlanadi:

$$\rho_{kp} = \sqrt{\frac{Q_{kp}}{\pi v_{kp}}} = \dots, M$$

5. Spiralar kameraning doimiylik koeffitsientini quyidagi formuladan topiladi:

$$K = \frac{\varphi}{r_a + \rho_{kp} - \sqrt{r_a(r_a + 2\rho_{kp})}},$$

bu yerda $r_a = \frac{D_a}{2}$; $r_b = \frac{D_b}{2}$.

6. Hisoblar jadval asosida φ° burchak oraliqini 15° o'zgartirib boriladi va ρ_i va R_i kattaliklari aniqlanadi va 20 - jadval to'ldiriladi.

20 - jadval

№ K-k	φ_i°	$\frac{\varphi_i^\circ}{K}$	$2r_a \frac{\varphi_i^\circ}{K}$	$\sqrt{2r_a \frac{\varphi_i^\circ}{K}}$	$\rho_i = \frac{\varphi_i^\circ}{K} + \sqrt{2r_a \frac{\varphi_i^\circ}{K}}$	$2\rho_i$	$R_i = 2\rho_i + r_a$
-	-	-	m	m	m	m	m
1	2	3	4	5	6	7	8
1							
2							
3							
....							

Ilova: 20-jadvalning 2 va 8 ustunlaridagi kattaliklar asosida spiralar kamera plani chiziladi (1-Ilova: 7-rasm).

3.7. Hidroturbina valini hisoblash

Val odatda 40 yoki 20 GS po'lotdan qilingan silindirik ichi g'avvak va oxirida flanslardan tashkil topgan. Valni uzunligi gidroagregatni umumiy kompanovkasi orqali olinadi [3].

Vallar bir butun (nisbatan kichik o'lechlarda) hamda bir necha bo'lakli tayyor qisimlarni payvandlash yo'li bilan tayyorlanadi. Valni

qabul qilingan tayyorlash texnologiya jarayoni texnik-iqtisodiy hisoblar orqali aniqlanadi.

Burama-kurakli turbinalarning pastki flansi shunday tayyorlanadiki u bir vaqtini o'zida turbina qopqog'ini bir bo'lagi bo'lib xizmat qiladi. (5 - rasm). Bunday qarorga ma'lum tokor stanogini imkoniyatiga qarab qabul qilinib, konstruksiyaning bu tugunini osonlashtiradi.

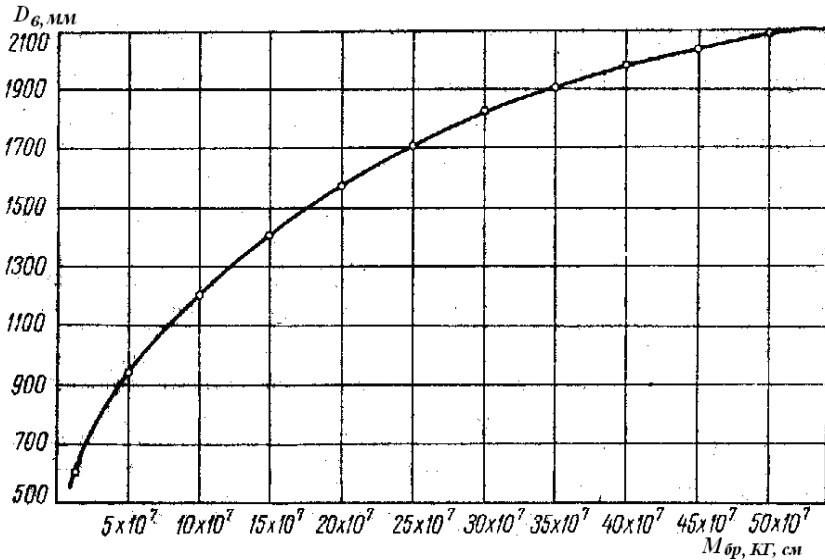

4 - rasm. Valning tashqi diametrini burovchi momentga bog'liqligi

BK turbina valining markaziy teshigida shtanga joylashib, u orqali bosim ostida moy qabul qilgichdan ishchi g'ildirak servomotoriga moy keladi va u ishchi g'ildirak zolotnigini servomotor bilan aksincha bog'lanishini amalga oshadi.

RO' turbina ishchi g'ildiragi orqasida oqimni ba'zi bir rejimda pulsatsiyalanishni kamaytirish maqsadida validagi markaziy teshikdan ishchi g'ildirak tagiga atmosfera bosimli havoni uzatiladi (4 - rasm)

Vertikal valni normallashtirilgan tashqi diametri D_v burovchi M_{br} moment kattaligiga qarab 4 - rasmning egri chizig'i bilan kesishgan nuqta mos bo'lgan kattalik aniqlanadi va 20 - jadvaldan topilgan qiymatga yaqin bo'lgan kichik o'lchami olinadi [2].

Burovchi moment teng bo'ladi:

$$M_{br} = 97400 N / n_{si}, \text{ kG.sm}$$

bu yerda N -val orqali uzatiladigan quvvat, kVt da;

n_{si} – valni aylanish tezligi ayl/min da.

Valning ichki diametri

$$d_{ich} = \sqrt[4]{D_v^4 - \frac{496102 * N * D_v}{\tau * n_{si}}}, \text{ sm.}$$

bu yerda D_v valning tashqi diametri, sm da; $\tau_{max} = 450 \text{ kG/sm}^2 \pm 10\%$ - maksimal yo‘l qo‘yilgan kuchlanish. Formula orqali topilgan ichki diametr quyidagi normallashtirilgan ichki diametrlar qatori kattaligi bo‘yicha yaxlitlanadi, (mm)da: 400; 420; 450; 480; 500; 530; 560; 600; 630; 670; 710; 750; 800; 850; 900; 950; 1000; 1050; 1100; 1200.

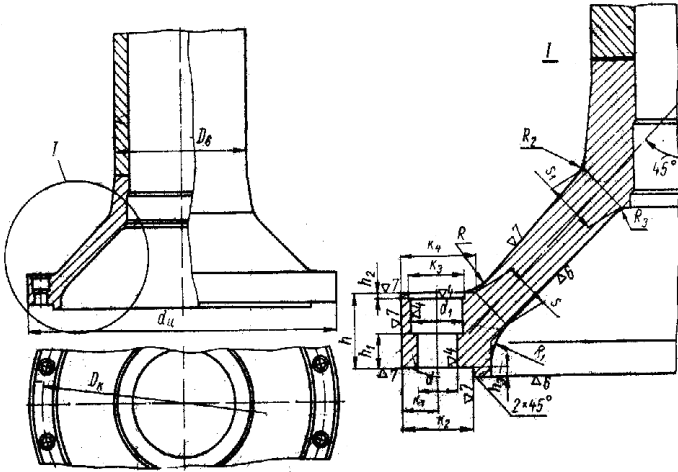

5 – rasm. Ishchi g‘idirak qopqog‘i bilan biriktirilgan buram-kurakli turbina vali

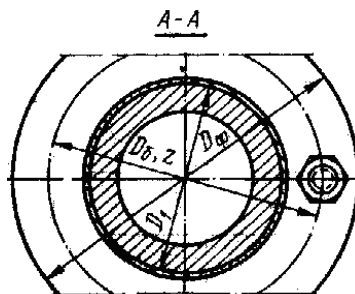
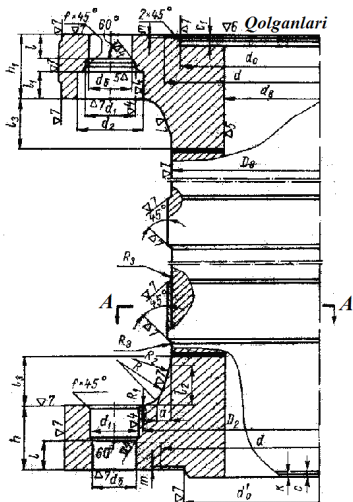

6 - rasm. Radial-o'qli turbina vali

Radial-o'qli turbina valning normallashtirilgan o'lchamlari, (v mm) da

21 -jadval

D _v	D ₁	D _f	h	h ₁	D _b	b _b	Bolt	Vint
600	605 _{-0,5}	1000 _{-0,5}	150	180	820	85A	M80x4	M16
650	655 _{-0,5}	1050 _{-0,6}	150	180	870	85A	M80x4	
700	705 _{-0,5}	1100 _{-0,6}	160	190	920	85A	M80x4	
750	755 _{-0,5}	1150 _{-0,6}	160	190	970	85A	M80x4	
800	805 _{-0,5}	1230 _{-0,6}	170	200	1045	85A	M80x4	
850	855 _{-0,5}	1300 _{-0,7}	170	200	1110	90A	M85x4	
900	905 _{-0,5}	1360 _{-0,7}	180	210	1165	95A	M90x4	M20
950	955 _{-0,5}	1490 _{-0,7}	195	230	1280	100A	M95x4	
1000	1005 _{-0,6}	1570 _{-0,7}	210	250	1350	105A	M100x4	
1100	1105 _{-0,6}	1660 _{-0,7}	225	260	1425	115A	M110x4	
1200	1205 _{-0,6}	1830 _{-0,7}	240	270	1575	125A	M120x4	M24
1300	1305 _{-0,6}	1940 _{-0,7}	250	280	1675	135A	M130x4	
1400	1405 _{-0,6}	2070 _{-0,8}	260	290	1800	145A	M140x4	
1500	1505 _{-0,6}	2160 _{-0,9}	270	300	1900	150A	M140x4	
1600	1605 _{-0,6}	2330 _{-0,9}	280	320	2030	170A	M160x4	M30
1700	1705 _{-0,6}	2450 _{-0,9}	290	330	2140	175A	M170x4	
1800	1805 _{-0,6}	2600 ₋₁	300	340	2280	185A	M180x4	
1900	1905 _{-0,6}	2710 ₋₁	310	350	2390	190A	M180x4	
2000	2005 _{-0,6}	2860 ₋₁	320	360	2515	195A	M190x4	
2100	2105 _{-0,6}	3015 ₋₁	330	370	2670	195A	M190x4	
2200	2205 _{-0,6}	3065 ₋₁	330	370	2720	195A	M190x4	
2300	2305 _{-0,6}	3245 ₋₁	340	380	2900	195A	M190x4	

21-jadvalning davomi

D_v	z	D_2	D_o	d_o	d	d_1	d_2	l	l_1	R
600	12	675	580 ^{+0,05}	580 _{-0,06}	—	87	122	40	55	100
650	16	725	640 ^{+0,05}	640 _{-0,06}	—	87	122	40	55	100
700	16	775	670 ^{+0,05}	670 _{-0,06}	—	87	122	40	55	100
750	18	825	740 ^{+0,05}	740 _{-0,06}	—	87	122	40	55	100
800	20	900	800 ^{+0,05}	800 _{-0,06}	—	87	122	40	55	100
850	20	950	850 ^{+0,05}	850 _{-0,06}	—	92	132	45	60	100
900	20	1000	900 ^{+0,06}	900 _{-0,06}	—	97	142	45	65	100
950	20	1100	900 ^{+0,06}	900 _{-0,06}	1050	102	153	50	65	120
1000	20	1160	950 ^{+0,06}	950 _{-0,06}	1100	108	158	50	70	120
1100	20	1220	1000 ^{+0,06}	1000 _{-0,06}	1200	118	173	50	75	120
1200	20	1350	1100 ^{+0,06}	1100 _{-0,06}	1300	130	188	60	85	120
1300	20	1440	1200 ^{+0,06}	1200 _{-0,06}	1400	140	203	60	90	120
1400	20	1560	1300 ^{+0,06}	1300 _{-0,06}	1500	150	218	60	100	120
1500	20	1660	1350 ^{+0,07}	1350 _{-0,07}	1600	153	230	70	100	120
1600	20	1760	1450 ^{+0,07}	1450 _{-0,07}	1700	174	255	80	110	125
1700	20	1860	1500 ^{+0,07}	1500 _{-0,07}	1800	180	260	80	120	125
1800	20	1990	1600 ^{+0,07}	1600 _{-0,07}	1950	190	265	85	125	125
1900	20	2100	1700 ^{+0,07}	1700 _{-0,07}	2050	190	270	90	125	125
2000	20	2200	1800 ^{+0,07}	1800 _{-0,07}	2150	200	285	90	135	125
2100	24	2355	1900 ^{+0,08}	1900 _{-0,08}	2250	200	285	95	135	140
2200	24	2405	2000 ^{+0,08}	2000 _{-0,08}	2350	200	285	95	135	150
2300	28	2585	2100 ^{+0,08}	2100 _{-0,08}	2450	200	285	100	135	160

Ishchi g'ildirakni qopqog'i bilan birlashtirilgan burama kurakli turbina valining o'lchamlari, mm.

22-jadval

d_g	d_s	D_v	z	d	d_1	k_1	k_2	k_3
M60	910-1200	350-500	16	65	88	55	110	94
M68	1225-1400	500-600	20	72	96	60	120	102
M76	1440-1600	600-750	24	80	110	70	140	115
M90	1625-1800	700-850	24	95	128	85	170	134
	1825-1900	800-850	28	95	128	85	170	134
M100	1950-2200	800-1000	28	105	145	95	190	150
M110	2225-2325	950-1100	28	115	155	100	200	160
M120	2400-2500	1000-1200	28	125	170	110	220	175
M130	2550-2675	1100-1300	28	135	185	115	230	190
	2725-2900	1200-1400	32	135	185	115	230	190
M140	2950-3250	1300-1500	32	145	200	125	250	205

k_4	h	h_1	h_2	h_3	s	S_1	$R=R_2$	R_1	R_3
120	110	42	10	15	70	95	80	100	40
130	120	42	10	15	80	100	80	100	40
142	130	42	10	15	85	105	80	100	40
185	160	70	10	20	90	110	100	120	50
185	160	70	10	20	100	120	100	120	50
205	180	75	15	20	100	135	100	120	50
220	200	85	15	25	110	140	100	150	50
240	220	95	15	25	110	140	120	150	60
255	240	105	15	30	130	155	120	180	60
255	250	115	15	30	140	165	120	180	60
280	260	120	15	30	160	195	130	200	60

4. Berilgan napor kattaligi bo'yicha gidroelektrstansiya binosi va to'g'on turini tanlash

O'zining tarkibida gidroelektrstansiya binosi bo'lgan gidrouzellar quyidagi bir qator belgilariga qarab tavsiflanadi [1]:

Naporni xosil qilish bo'yicha uchta sxemani ajratish mumkin:

- a) to'g'onli;
- b) derevatsiyali;
- v) to'g'onli-derevatsiyali (aralash).

Maqsadi bo'yicha:

- a) bir maqsadli;
- b) kompleksli.

Naporni hosil qilish va GES binosini to'g'onga nisbatan joylashishi bo'yicha:

- a) o'zanli;
- b) to'g'on orti;
- v) derevatsiyali.

Er ustiga nisbatan joylashishi bo'yicha:

- a) yer ustida;
- b) yarim yer ostida;
- i) yer ostida.

GES binosidan suvni tashlash bo'yicha:

- a) suv tashlagich bilan birikmagan (несовмещенные);
- b) suv tashlagich bilan birikkan (совмещенные) [1].

5. Gidroturbina suv o'tkazgichini hisoblash

Gidroturbina suv o'tkazgichini hisoblashda quvur diametri, mahalliy joylardagi va quvur uzunligidagi naporning yo'qolishi aniqlanadi. Buning uchun quyidagi amallar bajariladi:

a) Gidroturbina suv o'tkazgichini gidravlik hisoblash

GES binosiga keltiriladigan suv naporli quvurlar (daryodan, suv omboridan yoki derevatsiya kanali) orqali olib kelinadi

Bitta quvur orqali o'tadigan suv sarfi:

$$Q_{quv.} = \frac{N}{9,81 \cdot H_h \cdot \eta} \quad \text{yoki} \quad Q_{quv.} = Q_{ges}/n, \quad (m^3/s)$$

bu yerda n – quvurlar soni (maksimal 3 tagacha olish mumkin).

Iqtisodiy nuqatai nazardan eng qulay quvur diametrini tanlash quyidagi formuladan aniqlanadi;

$$D_{quv.} = 0,9 \cdot Q_{quv.}^{0,4}, \quad (m)$$

Aniqlangan quvur diametrini standart kattaligi tanlanadi [2].

Quvurdagi suv tezligi aniqlanadi: $v = Q_{quv.}/\omega$, (m/s)

bu yerda quvurni kesim yuzasi bo'ladi: $\omega = \pi D_{quv.}^2/4$ (m²).

Metalli yoki betonli quvurdan o'tayotgan suvni yo'l qo'yilgan tezligi v ni hisobiy napor H bo'yicha 2- rasmdan aniqlanadi [3].

b) Quvurda yo'qolgan napor kattaliklarini aniqlash

Quvurda yo'qotilgan napor, uni uzunligi va mahalliy qarshilikdagi yo'qotilgan naporlar yig'indisi orqali topiladi [8].

1) Quvurning uzunligi bo'yicha yo'qotilgan napor

Darsi – Veysbax formulasi orqali topiladi:

$$h_l = \lambda(l/d)(V^2/2g), \quad (m).$$

bu yerda l – quvur uzunligi, m;

d – quvur diametri, m;

λ - quvurni uzunligi bo'yicha gidravlik ishqalanish koeffitsienti ;

V – o'rtacha tezlik, m/s;

$$g=9.8 \text{ m/s}^2$$

B.L.SHifrensonni formulasi bo'yicha kvadrat qarshilik zonasi uchun $Re \geq 500$ d/Δ_e bo'lganda[9]:

$$\lambda = 0,11(\Delta_e/d)^{0.25}$$

Bu yerda Δ_e – ekvivalent g'adir-budurlik koeffitsienti (ilova 8.1.-8.5) [9].

Masalan:

- Yangi, choksiz yaxshi tayyorlangan quvurlar uchun $\Delta_e=0,025$;

-Yangi, toza va ichki tomoni zavoda bitum qoplangan $\Delta_e=0,016$;

- Eski, ozgina zanglagan, toza quvurlar uchun $\Delta_e=0,2$ va x.o.

2) Mahalliy qarshilikdagi naporni yo'qolishi qarshilikni turiga va soniga bog'liq bo'lib quyidagi formula orqali topiladi:

$$h_M = \xi(v^2/2g), \quad (m)$$

bu yerda ξ - maxalliy qarshilik koeffitsienti

Mahalliy qarshilik turlari:

1). Oqib kelayotgan suvdagi suzuvchi jisimlarni ushlab uchun uni yo'nalishiga to'g'ri qo'yilgan panjaradagi qarshilik [8].

$$\xi_{resh.} = \beta \cdot (S/b)^{1/3} \sin\alpha;$$

bu yerda β - sterjen formasiga bog'liq bo'lgan koeffitsient

2). Quvurga kirish :

a) silliq kirishda $\xi = 0,20$;

b) o'tkir qirrali kirishda $\xi = 0,50$.

3).Doirali quvurni α burchakka burilishidagi qarshilik koeffitsienti ξ .

Aniqlangan hamma mahalliy qarshiliklar koeffitsienti yig'indisi orqali yo'qotilgan napor hisoblanadi.

Quvurning uzunligi va mahalliy qarshiligida topilgan naporlar yig'indisi quyidagi formuladan aniqlash mumkin.

$$h_w = h_l + h_M = (\lambda \cdot l/d + \sum \xi) v^2/2g, \quad (m).$$

6. So‘rish quvurini hisoblash

Burama kurakli (PL) va radial o‘qli (RO) gidroturbinalarning ishchi g‘ildiragini diametri $D_1 = 1,0$ m bo‘lgan, so‘rish quvuri va seriyasi №4 bo‘lgan tirsakning o‘lchamlari 23-24-jadvallarda berilgan, hamda ularni qurish yo‘li 7-9 – rasmlarda ko‘rsatilgan. Gidroturbinaning turiga qarab so‘rish quvuri turi tanlanadi va uni chizmasi millimetr qog‘oziga chiziladi [6].

Turbina ishchi g‘ildiragining diametri $D_1=1,0$ m bo‘lgan, seriyasi №4 li so‘rish quvuri tirsagining asosiy o‘lchamlari

23-jadval

So‘rish quvuri turlari	So‘rish quvuri tirsagining o‘lchamlari										
	D_4	h_4	B_4	L_1	h_6	a	R_6	a_1	R_7	a_2	R_8
4A	1,10	1,1	2,2	1,417	0,55	0,395	0,94	1,205	0,660	0,087	0,634
4C yoki 4D	1,17	1,17	2,38	1,50	0,584	0,422	1,00	1,275	0,703	0,0934	0,677
4H	1,352	1,352	2,74	1,75	0,670	0,487	1,16	1,478	0,815	0,107	0,782
20	1,04	0,04	2,17	1,41	0,510	0,369	0,879	1,135	0,640	0,0803	0,59

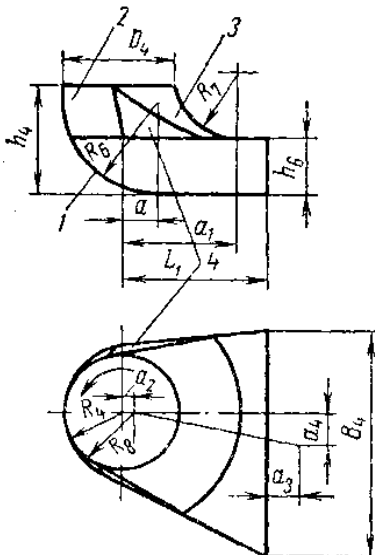

7 – rasm. Seriyasi № 4 bo‘lgan so‘rish quvurining tirsagini geometrik formasi va asosiy o‘lchamlarini belgilanishi: 1 – silindrlı sirt; 2 – konussimon sirt; 3 – torning sirti; 4 – qiyali tekislik

Turbina ishchi g'ildiragining diametri $D_1=1,0$ m bo'lgan, seriyasi №4 tirsakli so'rish quvurining asosiy o'lchamlari

24 - jadval

So'rish quvurining turlari	So'rish quvurining o'lchamlari									Ishlatish soxalari misoli
	h: D_1	h	L	B_5	D_4	h_4	h_6	L_1	h_5	
4A		1,915	3,50-4,5	2,20	1,10	1,10	0,55	1,417	0,95-1,03	PL20/ 510; PL20/661
4C yoki 4D	2,3	2,3	4,5	2,38-2,6	1,17	1,17	0,585	1,5	1,20-1,0	PL20/510; PL20/661; PL30/587; PL40-80/642
4H	2,5; 2,6; 2,7	2,5; 2,6; 2,7	4,5	2,4	1,352	1,352	0,67	1,75	1,23	PL10/592; PL15; PL20/510; RO45/123; RO75/702; RO115/697; RO170; RO170/638; RO230
20	2,3	2,8	3,50	2,170	1,04	1,04	0,510	1,410	0,94	RO310-500

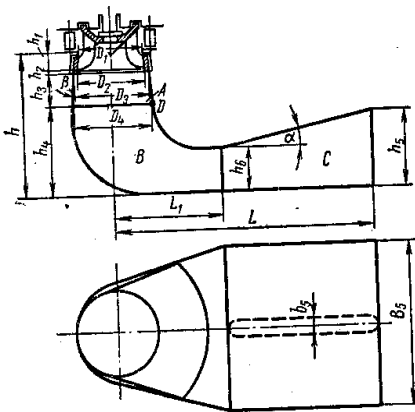

a)

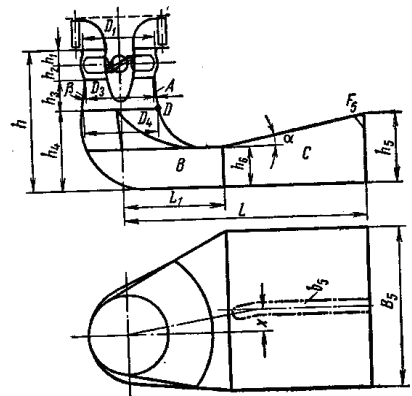

b)

8 - rasm. Seriyasi № 4 bo'lgan so'rish quvurlari: a) radial va b) burama kurakli gidroturbinaning egilgan so'rish quvuri

7. Hidrogeneratorning asosiy parametrlarini aniqlash

Gidrogeneratorning asosiy parametrlarini aniqlashda quyidagi birlamchi kattaliklar hisoblanadi: gidroturbinaning nominal quvvati N_T , uni nominal aylanish soni n , turbina turi va uni ishchi g'ildiraging diametri D_1 .

Gidroturbinaning nominal quvvati N_T , generatorning foydali ish ko'effitsienti η_{gen} , va quvvat ko'effitsienti $\cos\varphi$ orqali to'la quvvat S va aktiv quvvat N_{gen} aniqlanadi

$$N_{gen} = N_T \cdot \eta_{gen}.$$

$$S = N_{gen} / \cos\varphi;$$

GOST 5616-81 bo'yicha sinxron gidrogeneratorlarda yo'qolishlar qattiq chegaralangan bo'lib, nominal quvvatning ko'effitsienti $\cos\varphi$ gidrogenerator quvvati kattaligi orqali aniqlanadi.

25-jadval

$S_{gen}, MV \cdot A$	125 gacha	126-360	360dan ortiq
$\cos\varphi$.	0,8	0,85	0,9

Gidrogeneratorning taxminiy foydali ish ko'effitsientini 26-jadvaldan aniqlash mumkin.

26jadval

	n, ayl/min, aylanish soni			
	51,8-100	100-187,5	187,5-300	300-500
$S, MV \cdot A$	$\eta_{gen}, \%$			
25-60	96,15-96,8	96,5-97,1	96,3-97,0	96,1-96,9
60-100	96,8-97,2	97,1-97,8	97,0-97,6	96,9-97,5
100-125	97,5-98,3	98,2-98,3	98,0-98,3	-

GOST bo'yicha gidrogeneratorlar uchun standart nominal kuchlanishlar qatori quyidagicha: 3,15; 6,3; 10,5; 18,0; 20,0; 21,0; 24,0; kV. Quvvati 50 MVt dan yuqori bo'lgan gidrogeneratorlarda, quyidagi kuchlanishlardan foydalanish mumkin 13,8; 15,75 kV.

Agar GESlarda oldindan ishlab chiqilmagan gidrogeneratorlar o'rnatilsa, u holda 9-rasmdagi nomogrammadan foydalanish mumkin [7].

9 – rasmda, gidrogeneratorning parametrlarini umumiy

qonuniyatini o'zgarishini va ba'zi kattaliklarni aniqlashga yordam qiladigan, hamda geometrik kattaliklarni generator qutubining solishtirma yuklanishga bog'likligi nomogrammasi ko'rsatilgan

Bu yerda:

$S/2P$ -qutubga bo'lgan solishtirma yuklanish, kVA/qutub;

L_T -aktiv po'lat balandligi, sm.da;

τ - qutub bo'linmasi, sm.da;

G_a/G - aktiv materiallarning gidrogeneratorni umumiy massasidagi ulishi, % da;

G_e - gidrogeneratorning aktiv xajmidan foydalanganlik darajasini ko'rsatuvchi Esson koeffitsienti, $kVA/m^3 \cdot ayl/min.$;

G_g/S – gidrogenerator massasining quvvat birligiga bo'lgan nisbati, kg/kVA . da

Nomogrammadagi indeksi «1» bo'lgan kattaliklar gidrogeneratorlarni bir tomonlama havo bilan sovitish, indeksi «2» gidrogeneratorning aktiv qismini suv bilan sovitishni bildiradi. Suvda sovitiladigan sistemalar hozirgi paytda katta quvvatli bo'lgan gidrogeneratorlarda ishlatiladi. Hamma egri chiziqlar, o'rtacha kattaliklari o'zgarmas inersiyali T_a -7...9 sek. bo'lgan, gidrogeneratorlar uchun koordinatalar logorifmik sistemada qurilgan

Qutubga bo'lgan solishtirma yuklanish quyidagi formuladan aniqlanadi:

$S/2P$,

bu yerda r – gidrogenerator rotorining juft qutublari soni:

$$r = 3000/n.$$

undagi n -aylanishlar soni.

Solishtirma yuklanishning $S/2P$ juft qutub soniga bo'lgan nisbati kattaligi bo'yicha nomogrammadan qutub bo'linmasining τ_{min} - va $\tau_{maks.}$, sm. da kattaligi aniqlanadi. Imkonli aylanish soni $v_{ayl.}$, m/sek. da kattaligi aniqlanadi.

$$v_{ayl.min.} = 100 \cdot K_T \tau_{min};$$

$$v_{ayl.maks.} = 100 \cdot K_T \tau_{maks.}$$

Bu yerda K_T . gidroturbinaning tezlashish koeffitsienti $K_T = n_T / n$, bu tenglikda n_T – tezlashgan aylanish soni tezlashish xarakteristikasi orqali aniqlanadi. Agar tezlashish xarakteristikasi bo'lmasa tezlashish koeffitsienti K_T quyidagi kattaliklarda olinadi:

(1,6-1,7) – sekin yuruvchi RO' GT uchun;

(1,7-1,9) – normal tez yuruvchi RO‘ GT uchun;

(1,9-2,1) – tez yuruvchi RO‘ GT uchun;

(2,0-2,2) – kombinator bog‘likni saqlagan BK (PL) GT uchun;

(2,2-2,6) – kombinatorli bog‘likni buzgan BK (PL) GT uchun.

Yo‘l qo‘yilgan qutub bo‘linmasi kattaligi quyidagicha aniqlanadi:

$$\tau_{\text{maks.yo'l q.}} = v_{\text{ayl. chegar.}} / 100 \cdot K_T$$

bunda aylanish tezligining chegaraviy sonini kattaligi quyidagicha qabul qilinadi:

-gidrogeneratorlarning quvvati 175 MVA kam bo‘lganda

$$v_{\text{ayl. chegar.}} = 160 \text{ m/s,}$$

-gidrogeneratorlarning quvvati 175 MVA katta bo‘lganda

$$v_{\text{ayl. chegar.}} = 185 \text{ m/s}$$

Gidrogeneratorning asosiy o‘lchamlari: stator diametri D_i va aktiv po‘lat balandligi L_t hisoblanadi. Statorning mumkin bo‘lgan diametri quyidagicha aniqlanadi :

$$D_{i \text{ min.yo'l q.}} = (2r \cdot \tau_{\text{min.}}) / \pi;$$

$$D_{i \text{ maks.yo'l q.}} = (2r \cdot \tau_{\text{maks.}}) / \pi.$$

Olingan kattaliklar chegarasida konstruktiv fikrlashdan kelib chiqqan holda stator qirgimi diametri D_i kattaligi beriladi.

Agar pastki krestovina bo‘lsa, uni ajratib olish sharti bilan stator diametri $D_i > D_{\text{sh}} + 0,6$ m. kattalikda tayinlanadi. Agar pastki krestovina bo‘lmasa, turbina qopqog‘ini yoki yo‘naltiruvchi apparatning yuqorigi halqasini olib o‘tish sharti bilan $D_i > D_{\text{sh}} + 0,2$ m qilib tayinlanadi. Mashina zali past bo‘lsa, rotor generator karterida (o‘rasida) yig‘ilsa, yo‘naltiruvchi apparatning yuqori halqasini rotorning ajratib olinadigan halqasi ichidan olib o‘tishni ta‘minlash uchun $D_i > D_{\text{sh}} + 0,2$ m. qilib tayinlanadi. Turbina shaxtasi diametri D_{sh} gidroturbina ishchi g‘ildiragi diametriga bog‘liq holda aniqlanadi $D_{\text{sh}} = (1,3-1,5) D_i$.

Statorning tayin bo‘lgan diametri bo‘yicha qutub bo‘linmasi τ aniqlanadi va

$\tau_{\text{min.}} < \tau < \tau_{\text{maks.}}$ bo‘lgan shartiga rioya qilish tekshiriladi .

Statorning aktiv po‘lat balandligi quyidagi formuladan aniqlanadi:

$$L_t = S / (D_i^2 \cdot n \cdot C_E),$$

Bunda $L_{t \text{ min.}} < L_t < L_{t \text{ maks.}}$ shart bajarilishi kerak, $L_{t \text{ min.}}$, L_t , $L_{t \text{ maks.}}$ va S_e kattaliklar esa 11 - rasmdagi nomogrammaning solishtirma qutub kattaligi bo‘yicha aniqlanadi.

L_t kattaligi ko'rsatilgan qiymatlar orqali tanlanadi 45, 50, 55, 60, 67, 75, 82, 90, 100, 110, 122, 130, 135, 150, 165, 182, 200, 220, 245, 270, 300 sm.

Stator diametrini, uni aktiv po'lat balandligiga bo'lgan nisbati gidrogeneratorning konstruktiv tuzilishini aniqlaydi. $D_i / L_t < 4$ nisbatda osma, $D_i / L_t > 5$ zontli gidrogenerator qabul qilinadi. Agar $D_i / L_t = 4-5$ va aylanish soni $n > 150$ ayl/min. bo'lsa osma gidrogenerator olinadi.

GD^2 - aylanuvchi massa inersiyasini xarakterlovchi burovchi moment;

bu yerda G – aylanuvchi agregat qismining massasi, t.;

D – o'qqa nisbatan aylanayotgan rotor massasining inersiya diametri, m; u holda gidrogeneratorning geometrik o'lchamlari quyidagi formula orqali aniqlanishi mumkin:

$$GD^2 = 6,53 \cdot D_i^{3,4} \cdot L_t.$$

Gidrogenerator inersiya doimiysi asosiy kattalik hisoblanadi. T_a doimiy inersiya kattaligi, gidroturbinani boshqarish va energotizimda generatorni dinamik turg'un

ishlashini kafolatlaydi. Son jixatidan generatorni to'la quvvati S , kVA teng bo'lgan, elektr tarmoq tomonidan tizimga qo'yilgan aylanish momenti ta'sirida, rotor tinch holatdan nominal aylanish sonigacha etishishi, generatorning doimiy inersiyasi vaqtiga teng.

Generator inersiyasi doimiysini, generator koeffitsienti $\cos \varphi = 1$ da nominal quvvati N_{gen} teng bo'lgan elektr quvvatini istimolchiga ulangan paytida, turbinaga keladigan suvni birdan to'xtatilganda agregatni to'xtashiga ketgan vaqt deb hisoblash mumkin.

Doimiy inersiya sekunda quyidagi formula orqali topiladi:

$$T_a = (GD^2 \cdot n^2 \cdot \eta_{gen}) / 365 \cdot S$$

Agar $T_a = 7-9$ sek bo'lsa, generatorning o'lchamlari va parametrlari to'g'ri olingan deb topiladi.

Gidrogenerator massasi quyidagi formuladan aniqlanadi:

$$G_{gen} = (G / S) \cdot S$$

Aktiv po'latning standart kattaligi quyidagicha: 33, 36, 40,

Bu erda (G / S) - solishtirma temir hajmi, kg/kVA da 11 - rasmdagi nomogrammadan topiladi.

Shu sababdan zontli qilib tayyorlangan, pyatasi turbina qapqog'iga tiralgan gidrogenerator massasini nomogrammadan olingan massaga nisbatan 7....10% kamaytirish kerak, yani

$$G_{zon,gen}=(0,9-0,93) \cdot G_{gen}.$$

Gidrogenerator rotorini massasi umumiy massaning yarmisiga teng qilib olinadi.

$$G_{rot}=0,5 \cdot G_{gen}$$

a) Zontli tipdagi gidrogeneratorning asosiy o'lchamlarini hisoblash

11 - rasmda zontli gidrogenerator turi sxemasi ko'rsatilgan bo'lib, podpyatnik vannasini konusli taglikga o'rnatilib, turbina qopqog'iga tiralgan qilib tayyorlangan. Bunday sxemani gidroturbinaning ishchi g'ildiragi $D_1 > 5$ m bo'lsa qabul qilish mumkin.

Asosiy o'lchamlar:

Statorni tashqi diametri,

$$n \geq 100 \text{ ayl/min bo'lganda } D_1 = (1,05 - 0,0017 \cdot n) \cdot D_i;$$

$$n < 100 \text{ ayl/min bo'lganda } D_1 = (1,05 - 0,002 \cdot n) \cdot D_i.$$

Statora balandligi: $h_1 = (1,7 - 1,9) \cdot L_t.$

Havo sovutgich tagini diametri: $D_2 = D_1 + (0,6 - 0,8 \text{ m}).$

Havo sovutgich balandligi: $h_2 = L_t.$

Rotor balandligi: $D_3 = D_1 - 2 \cdot \delta,$

bu yerda havo bo'shlig'i zatori $\delta = 0.$

Rotor balandligi: $h_3 = L_t + (0,5 - 0,8 \text{ m}).$

Yuqori krestovinning diametri statorni tashqi

diametriga teng qilib olinadi: $D_4 = D_1.$

YUqorigi krestovinning balandligi: $h_4 = (0,1 - 0,12) \cdot D_i \geq 0,4 \text{ m}.$

Podpyatnik vannasi diametri: $D_5 = (0,4 - 0,5) \cdot D_i.$

Podpyatnik balandligi: $h_5 = (0,1 - 0,12) \cdot D_i.$

O'rnatilgan regulyator ustmasi diametri:

$$D_6 = (0,15 - 0,25) \cdot D_{i..}$$

Ustmaning balandligi: $h_6 = (0,3 - 0,5 \text{ m}).$

Burama kurakli (PL) gidrogeneratori komponentovka (yig'ilgan) qilingan paytda moy qabul qiluvchining diametrini aniqlanadi:

$$D_7 = (0,35 - 0,4) \cdot D_{i..}$$

Moy qabul qiluvchining balandligi: $h_7 = 1,5 - 1,8 \text{ m}.$

Gidrogeneratorning tashqi diametri: $D_8 = D_2 + (0,3-0,5 \text{ m.})$.

Stator tagidagi havo kanalining balandligi: $h_{13} \geq 0,8 \text{ m.}$

Stator ustidagi havo kanalining balandligi: $0,3 \leq h_8 \leq h_4$.

Generator rotori va tormoz qiluvchi qurilmani orasidagi zazor balandligi:

$$h_{10} = 0,01 \text{ m.}$$

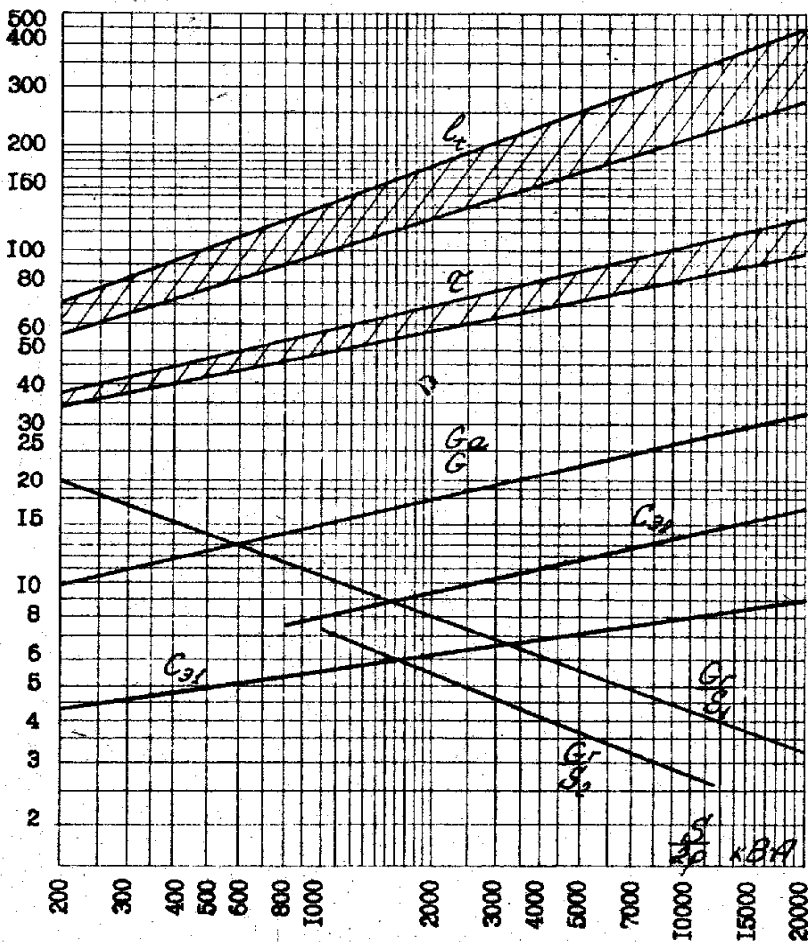

9-rasm. Nomogramma

Tormoz qurilmasini balandligi: $h_{11} = 0,3 \text{ m.}$

O'tish gabariti: $h_{12} = 1,9-2,0 \text{ m.}$

Ishchi g'ildirak diametri 5 m kichik bo'lsa, gidrogenerator sxemasida podpyatnik pastki krestovinada joylashadi. Bunday gidrogenerator 10-rasmda ko'rsatilgan, uni asosiy o'lchamlari podpyatnikni ishchi g'ildirak qopqog'iga tiralgan qilib olinadi. Unda quyidagi qo'shimcha hisoblar bajariladi:

Pastki krestovina diametri: $D_9 = D_{sh} + (0,3-0,5 \text{ m.})$.

Pastki krestovina balandligi: $h_9 = (0,25-0,30) \cdot D_{sh}$.

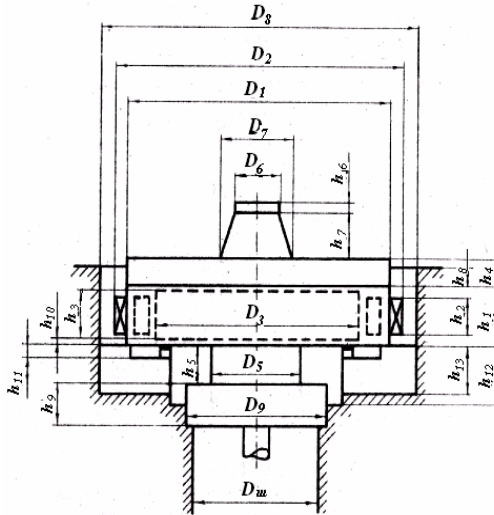

10-rasm. Podpyatnigi turbinaning pastki krestovinasiga tiralgan zontli gidrogenerator

b) Osmo gidrogeneratorning asosiy o'lchamlarini hisoblash (12-rasm).

2-ta yo'naltiruvchi podshipnikli osma turli gidrogenerator, podpyatnik vannasi yuqori krestovinada, gidroturbinani moy qabul qilgichi va podpyatnik tepasida generator regulyatori va pastki krestovinada tormozlar joylashgan qilib tayyorlanadi.

Osmo gidrogeneratorni asosiy o'lchamlari (12-rasm) quyidagi nisbatda aniqlanadi:

$n \leq 250$ ayl/min bo'lganda $D_1 = (1,15 + 0,0008n) D_i$;

$n > 250$ ayl/min bo'lganda $D_1 = (1,05 + 0,0017n) D_i$

YUqori krestovinani balandligi: $h_4 = (0,2-0,25) D_i$.

Pastki krestovinani balandligi: $h_9 = (0,10-0,12) D_{sh}$.

Osma gidrogeneratorning o'lchamlarini hisoblash ishlari xuddi zontli gidrogeneratorni hisobiday amalga oshiriladi.

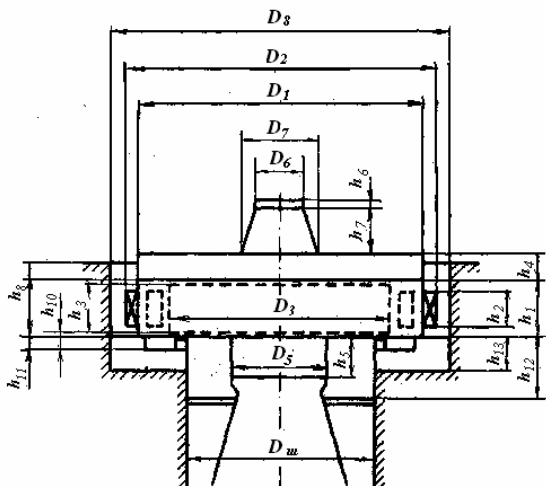

11-rasm. Podpyatnigi turbina qapqog'iga tiralgan zontli gidrogenerator

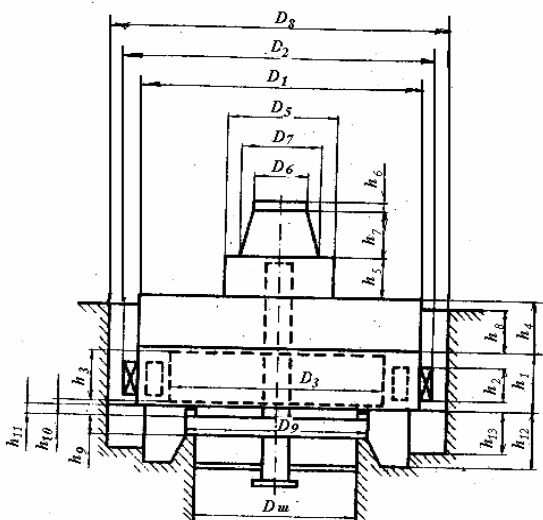

12 – rasm.Osma turdagi gidrogenerator
8. O'rnatiladigan ishchi g'ildirak o'qining balandlik belgisini (otmetkasini) aniqlash

Ishchi g'ildirak o'rnatilgan belgisini aniqlashda, $H=f(Q)$ xarakteristikasini tagiga o'sha masshtabda $V_{pb}=f(Q)$, bog'liqlik grafigi quriladi.

H_s ni egri chizig'i quvvatning chegara chizig'ida kesishgan nuqtasini $V_{pb}=f(Q)$ egri chizig'iga olib o'tamiz va $V_{pb}=f(Q)$ dan H_s kerakli nuqtalarini quyib chiqamiz. Eng pastki nuqta ishchi g'ildirakni o'qining V_{ig} belgisi bo'ladi.

8. GES binosini kompanovka qilish, montaj va ta'mirlash ishlari

Stansiya binosining asosi har xil yer materiallar ustida, yani toshli yoki tuproqli asosda joylashishi mumkin.

Stansiya binosida hisoblarga asosan har biri N quvvatli (mVt) bo'lgan n ta agregat joylashishi mumkin.

Agar hisob bo'yicha betonli spiral kamera bo'lsa, u holda spiral kamerani o'rab olish burchagi $\varphi=180^\circ$ qilib olinsa, uning eni V ni, $V/D_I=2.5-2.6$ nisbatdan topish mumkin.

Umuman hamma o'zanli va ba'zida derivatsiyali GES kanallarda o'rnatilib suv bosimini qabul qilsa, burama kurakli turbinalar taviyali kesimli betonli spiral kameralarga o'rnatiladi. Suv tashlagich bilan qurilgan GES binosi, simmetrik taviyali spiral kamerani o'rniga to'liq yoki to'liq emas yuqoriga qaragan nosimmetrik kesim yuzali qilib bajariladi. GES umumiy quvvati va agregatlar soniga qarab bloklarga bo'linadi. V_{bl} blok enini topish uchun V (spiral kamerani) eniga ikkita yarim ustunlar (bъchoklar) enini qo'shish kerak.

Napor 80 metrgacha bo'lganda betonli spiral kamerali GESning bitta blokni eni $V_{bl}=(2,9-3,1) D_I$ qilib olinadi.

Stansiya binosi asosi yumshoq materialdan tashkil topsa, blok eni yo'g'on ustun(bъchok)lar hisobiga $\{ V_{bl}=(4-4,5)D_I \}$ ga kattalashishi mumkin

40 m.dan 80 m. gacha naporlar oralig'ida, $N > 50m$ bo'lganda metalli qoplamaga ega bo'lgan betonli hamda metalli spiral kameralar ham ishlatish mumkin, u holda metalli spiral kameralar blokini eni V va $\{ V_{bl}=(4-4,5)D_I \}$ ga kattalashishi mumkin. Katta naporlarda bu o'lchamlar kamayishi mumkin va $\{ V_{bl}=(3-3,5)D_I \}$ bo'ladi.

Spiral kamera metalli qilib olinsa, u holda o'rab olish burchagi $\varphi=345-360^\circ$ teng qilib olinadi...

Agar montaj maydoni bilan $\Delta MM = \Delta MZ$ mashina zali maydoni teng bo'lsa, agregatlar soni kam bo'lganda (4-5 ta) montaj maydonini uzunligi $L_{MM} = (1-1,2)V_{bl}$ qilib olinadi. Texnologik loyihalash normasiga asosan montaj maydonchasi $1,5V_{bl}$ kattalikdan oshmasligi kerak (13-rasm), agregatlar soni ko'p balsa bu qonundan chetlashib $L_{MM} = (1,5-2)V_{bl}$ qilib olinadi.

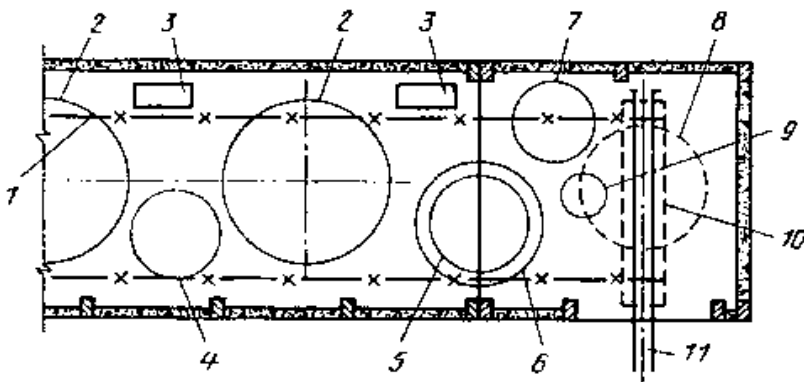

13-rasm. Frontal yo'lakli montaj maydoni.

1-bosh ilmoqni ishchi zonasi; 2- yig'ilgan agregatlar; 3-MNU; 4-turbina qarqog'i; 5-gidrogenerator rotori; 6-yuqorigi krestovina; 7 - ishchi g'ildirak; 8-yuqorigi krestokinani birlamchi joylashishi; 9-pyata podpyatnikli tayanchi bilan; 10-vagon (9platforma); 11-maydonga kiruvchi temir yo'l o'qi.

Mashina zali uzunligi $L_{MZ} = nV_{bl} + L_{MM}$ teng qilib olinadi. Agar ikkita katta kran ishlatilsa, u holda mashina zalining yon tomoni uzunligi, V_{bl} uzunligidan ΔL ga uzaytiriladi, u holda mashina zalini ham uzunligi L_{MZ} ga uzayadi.

Bu erda n –agregat bloklari soni;

Agregat o'qlari orasidagi masofa $V_{o'q} = V_{bl}, m$;

Mashina zali binosining eni V_{MZ} generator kojuxi $D_{KG} = D_8$ (9,10,11-rasmga qara) bog'liq. O'rtacha mashina zalining eni $V_{MZ} = D_{KG} + 5 m$ teng.

Mashina zalining to'la balandligi, rotorni val bilan bo'lgan balandligi yoki ishchi g'ildirak balandligining ilib oluvchi qurilmasi bilan, agregatni tepasidan 0,5 m., kran ilmog'ini ilish (zastropka),

ilmoqni olib chiqish, ko'priksimon kranni balandligi va kran lebedkasi va uni tepasida 0,8-1,0 m zaxira bo'lgan balanliklar yig'indisi, tomni fermasigacha bo'lgan masofa hisoblanadi. Ikkita kran bilan ish bajarilsa (montaj yoki demontaj) qilinsa, u holda traversni balandligi hisobga olinadi [4].

Mashina zali ko'priksimon kran bilan jihozlangan bo'lib, u orqali gidroagregatni yig'ish (montaj) qilish va ta'mirlash ishlarini bajarish mumkin.

GES binosiga suvni suvqabul qilgich orqali keltiriladi va u axlat ushlovchi panjara, remontli va avariya-reмонтli zatvorlar bilan ta'minlangan. Panjara va zatvorlarni kranlar (echkisimon, ko'priksimon va x.o.) orqali ishlatiladi.

GES binosiga suvni ikkita (3 ta) quvur bilan olib kelinadi.

GES binosidan suvni so'rib olish kanallari orqali olib ketilib pastki befga tashlanadi. So'rish quvuri ikkita bo'lakka bo'lingan bo'lib, uni oxiriga tamirlash zatvorlari o'rnatiladi. Zatvorlarni ishlatish echkisimon yoki boshqa kranlar bilan amalga oshiriladi.

Agregat osma yoki zontli generator bilan jihozlangan. Gidrogenerator o'qini belgisi ▼ m . belgida joylashgan..

Gidroturbinaning suv o'tkazuvchi qismni quritish uchun nasos agregati ko'zda tutilishi kerak. Nasoslar kollektorlar orqali bir-biri bilan bog'liq bo'ladi. Suv agregatlardan kollektorlarga to'kilib nasos qudug'iga tushadi va u erda nasoslar yordamida pastki befga (PB) haydab chiqariladi.

Stansiya binosini tashqarisida ochiq taqsimlash qurilmasi (ORU) joylashib, unda generatorda ishlab chiqilgan tokning kuchlanishi transformatorlar orqali kuchaytirilib uzatish tizimlari yordamida istimolchilarga uzatiladi.

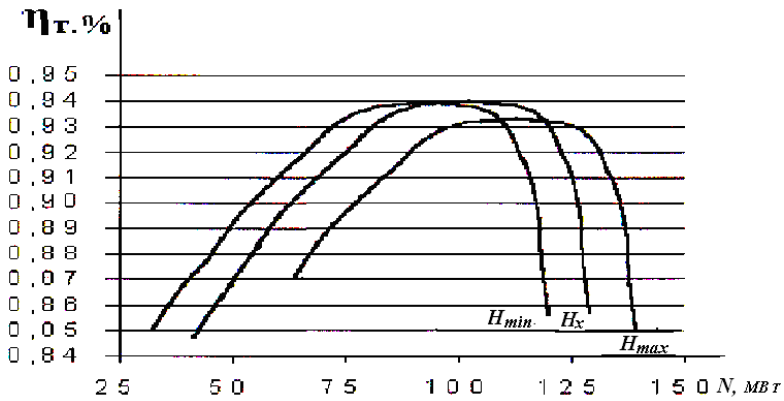

1- rasm. $\eta=f(N)$ xarakteristikasi

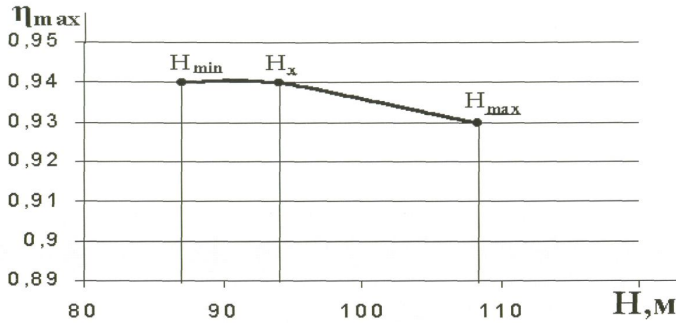

2 - rasm. $\eta = f(N)$ xarakteristikasi

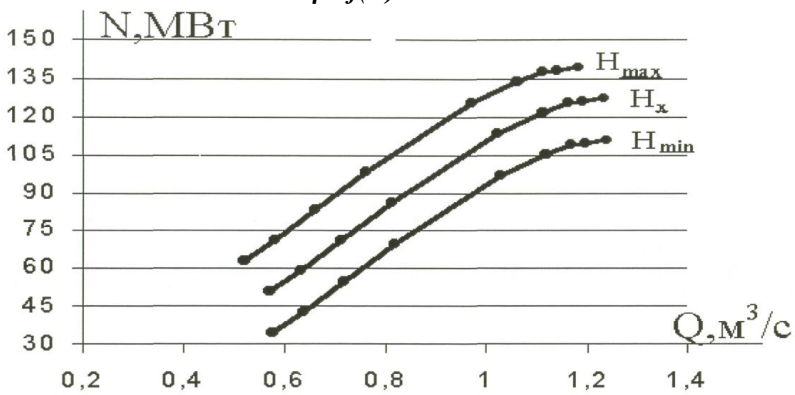

3 - rasm. $N=f(Q)$ bog'lanish grafigi

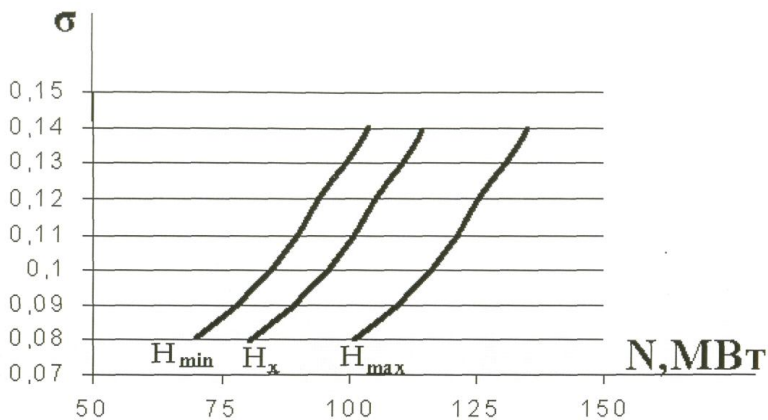

4 - rasm. $\sigma = f(N)$ bog'lanish grafigi.

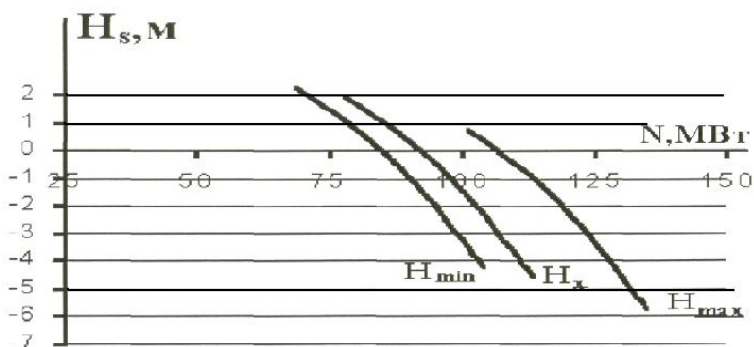

5 - rasm. $H_s = f(N)$ xarakteristikasi

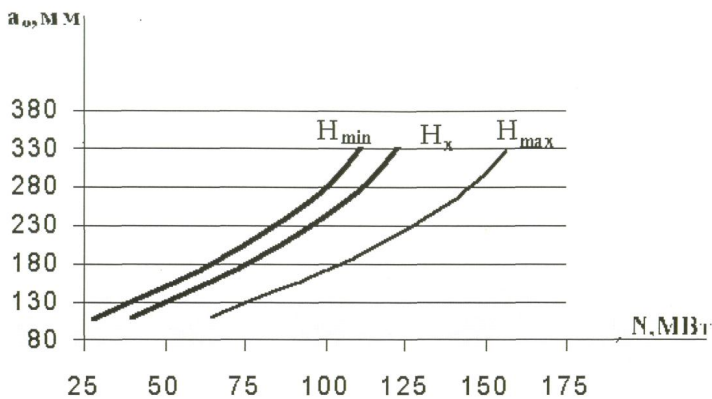

6 - rasm. $a_0 = f(N)$ xarakteristikasi

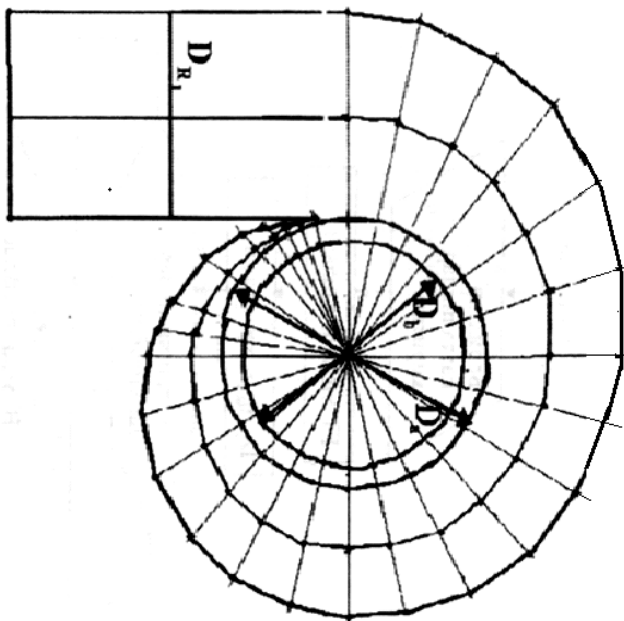

7-rasm. Metalli spiral kamerani tuzilishi

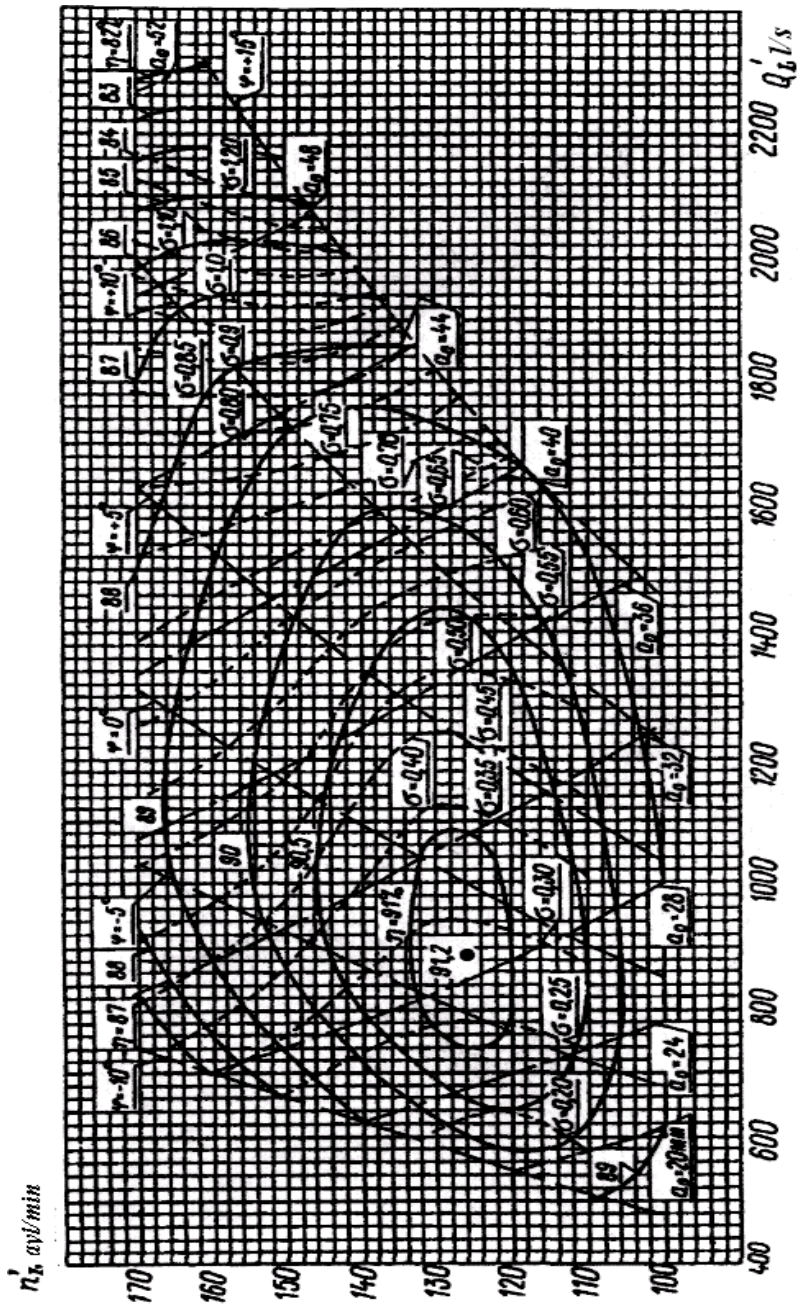

1- rasm . BK30/800-46 turbina ishchi g'ildiragining bosh universal xarakteristikasi

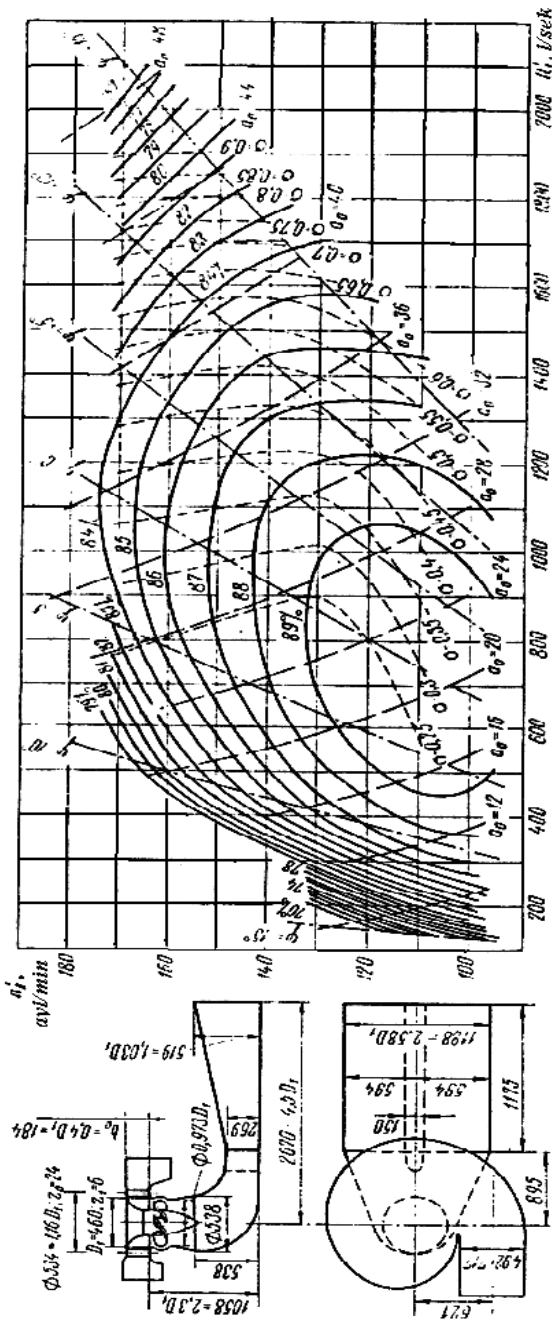

2- rasm . BK30/587 turbina ishchi g'ildiragining bosh universal xarakteristikasi

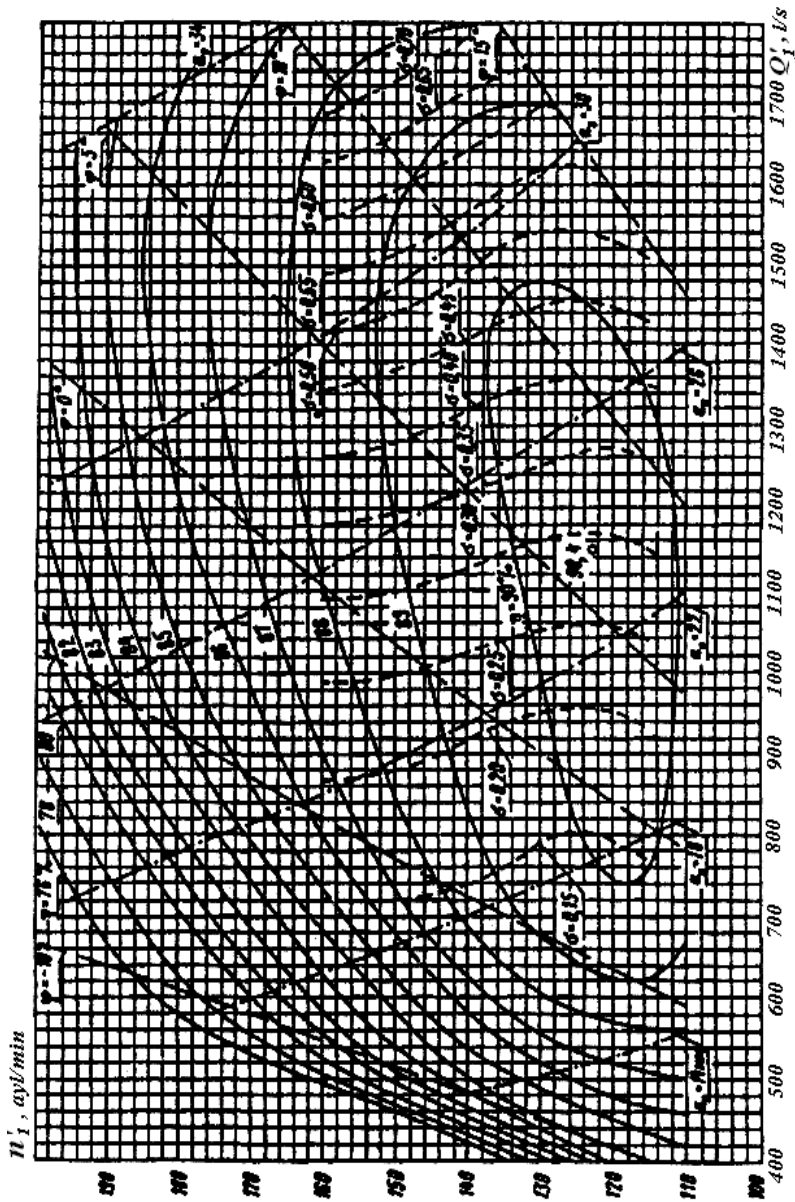

2- rasm . BK40587a-46 turbina ishchi g'ildiragining bosh universal xarakteristikasi

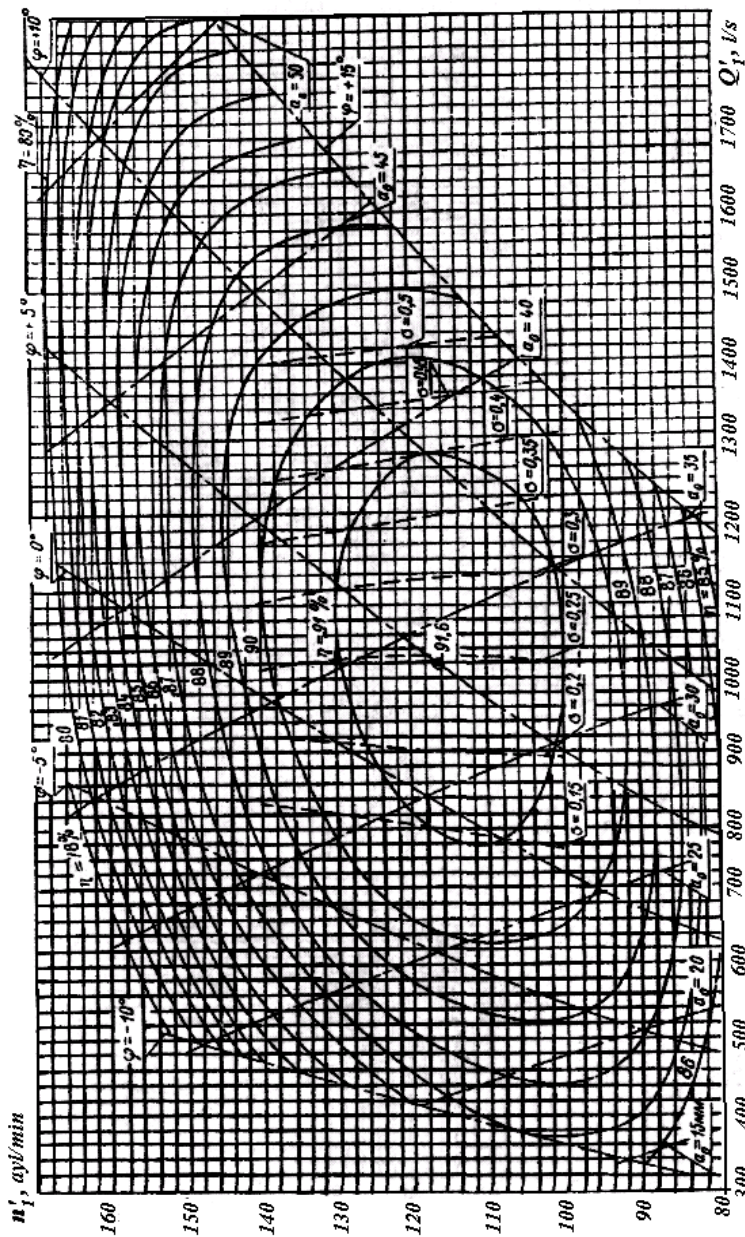

3- rasm . BK50/1075-46 turbina ishchi g'ildiragining bosh universal xarakteristikasi

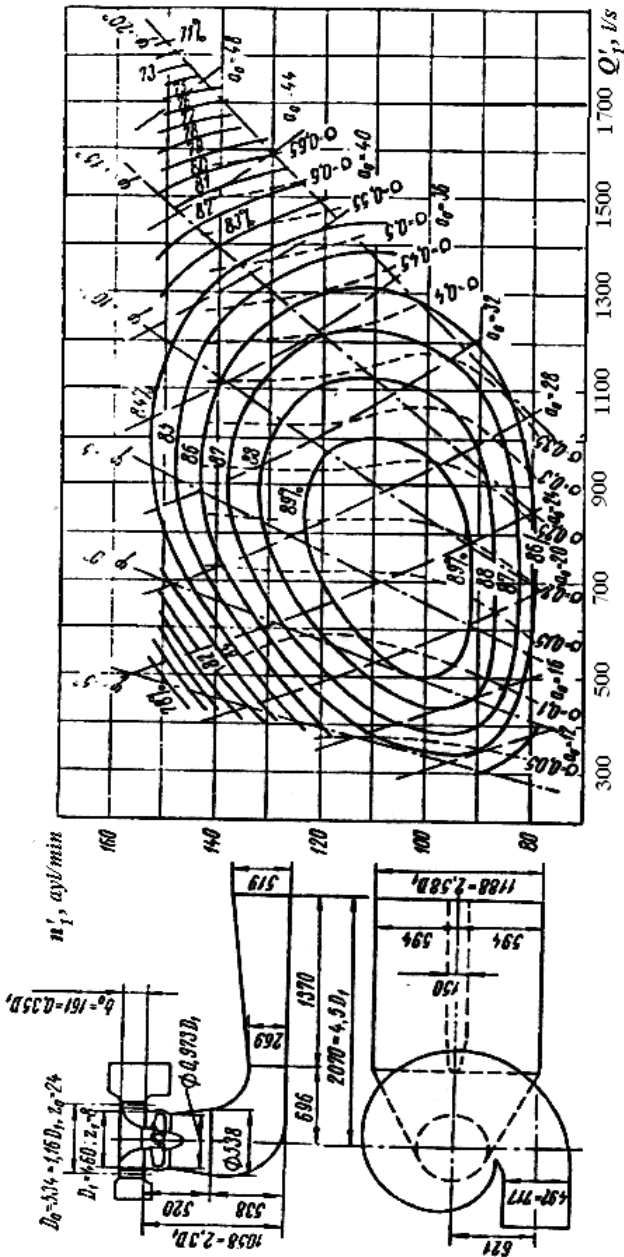

4- rasm . BK50/642 turbina ishchi g'ildiragining bosh universal xarakteristikasi

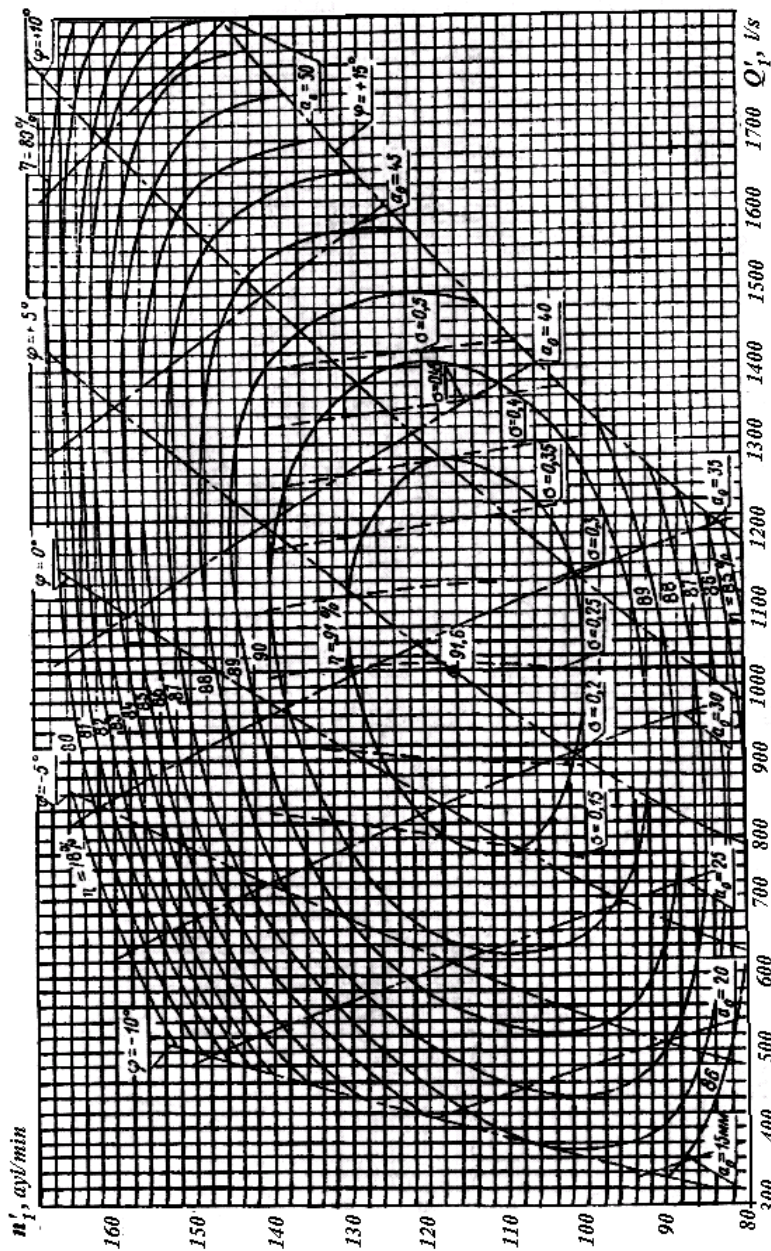

5- rasm . BK60/642-46 turbina ishchi g'ildiragining bosh universal karakteristikasi

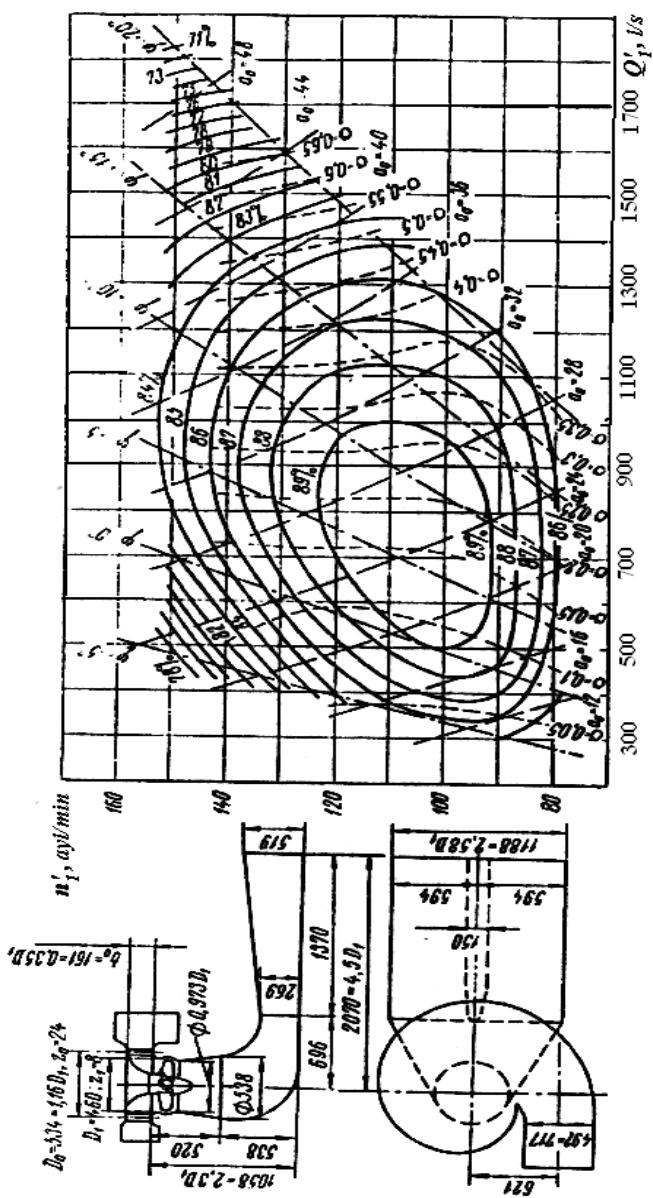

6- rasm . BK 60/642 turbina ishchi g'ildiragining bosh universal xarakteristikasi

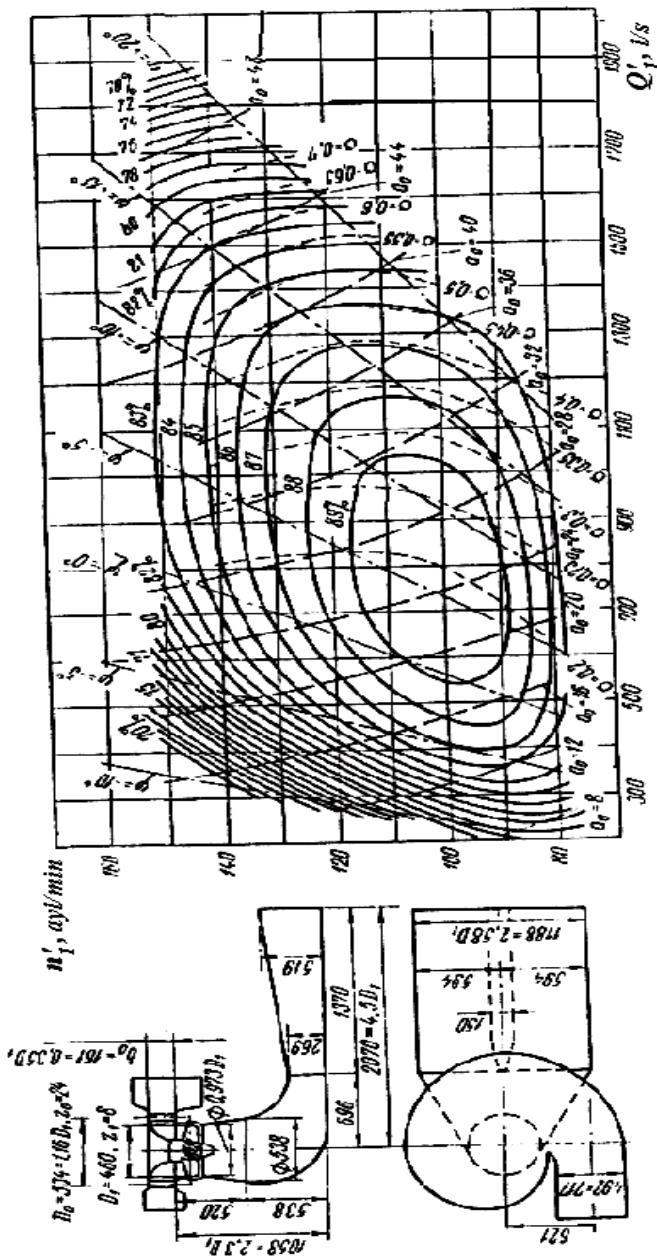

7- rasm . BK60/5A turbina ishchi g'ildiragining bosh universal xarakteristikasi

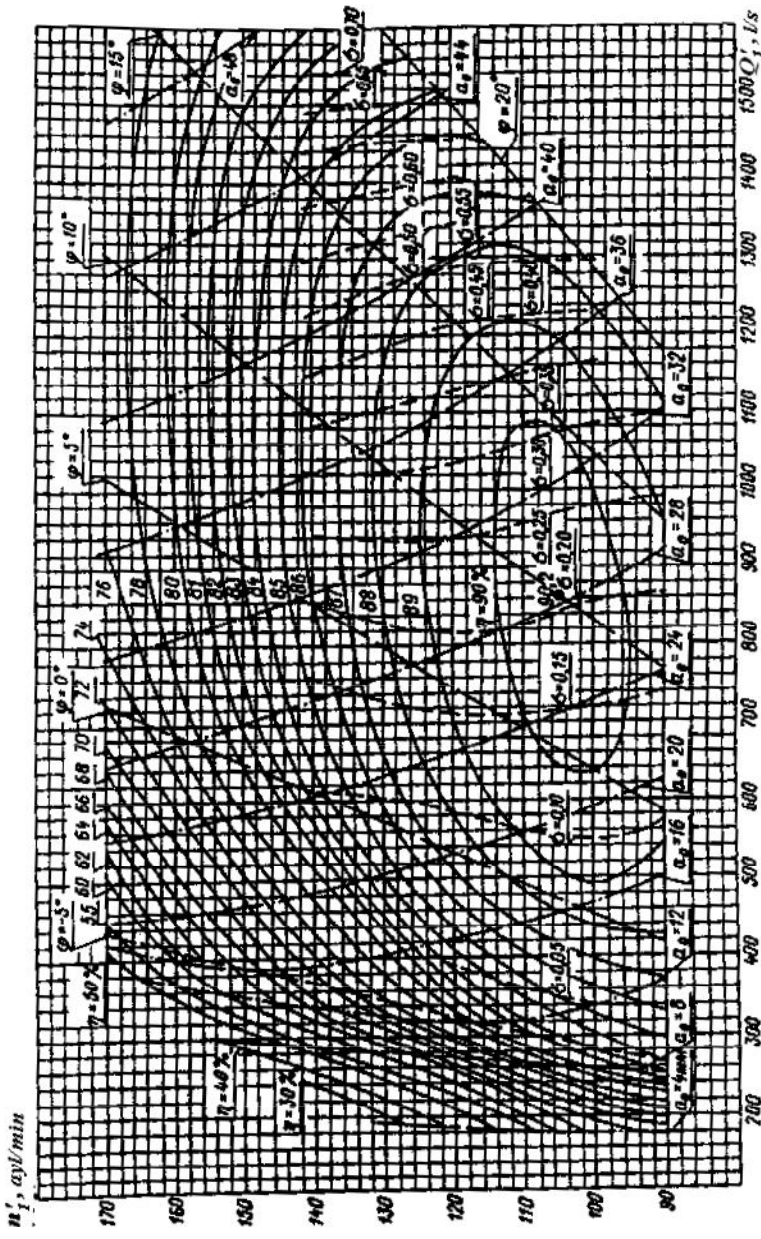

8.- rasm . BK70/642 -46 turbina ishchi g'ildiragining bosh universal xarakteristikasi

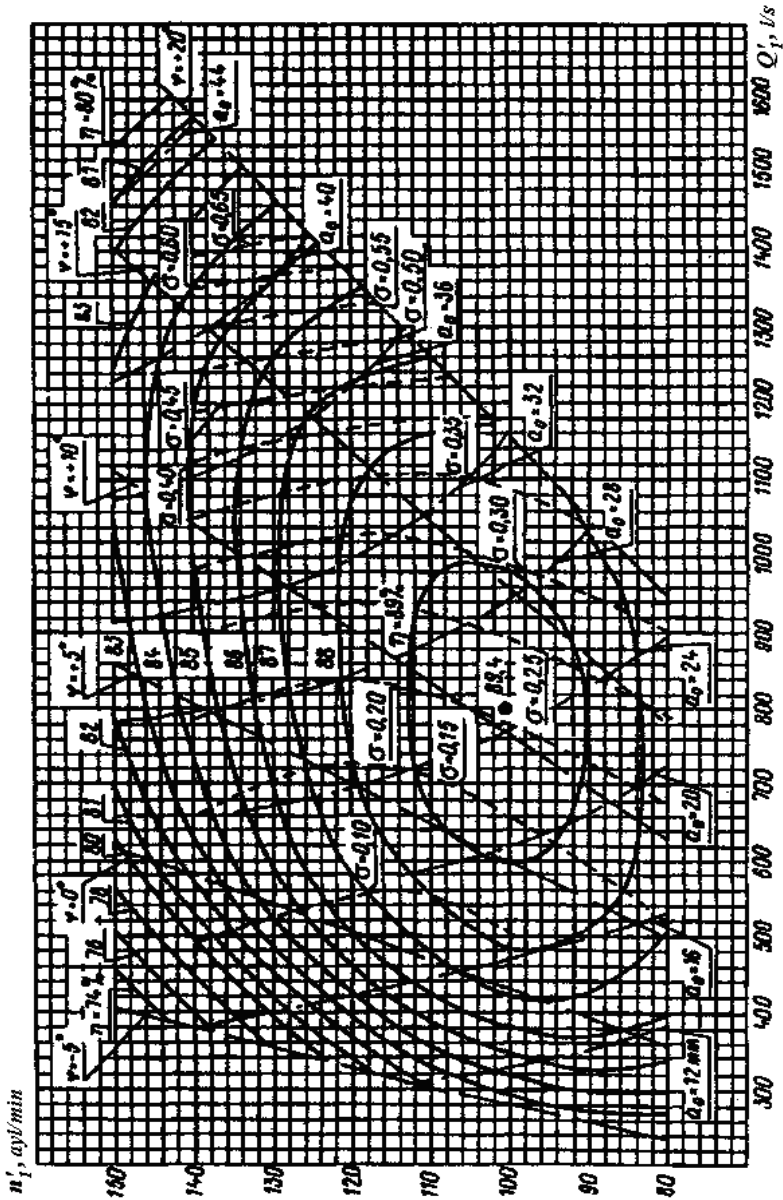

9- rasm. BK80/642-46 turbina ishchi g'ildiragining bosh universal xarakteristikasi

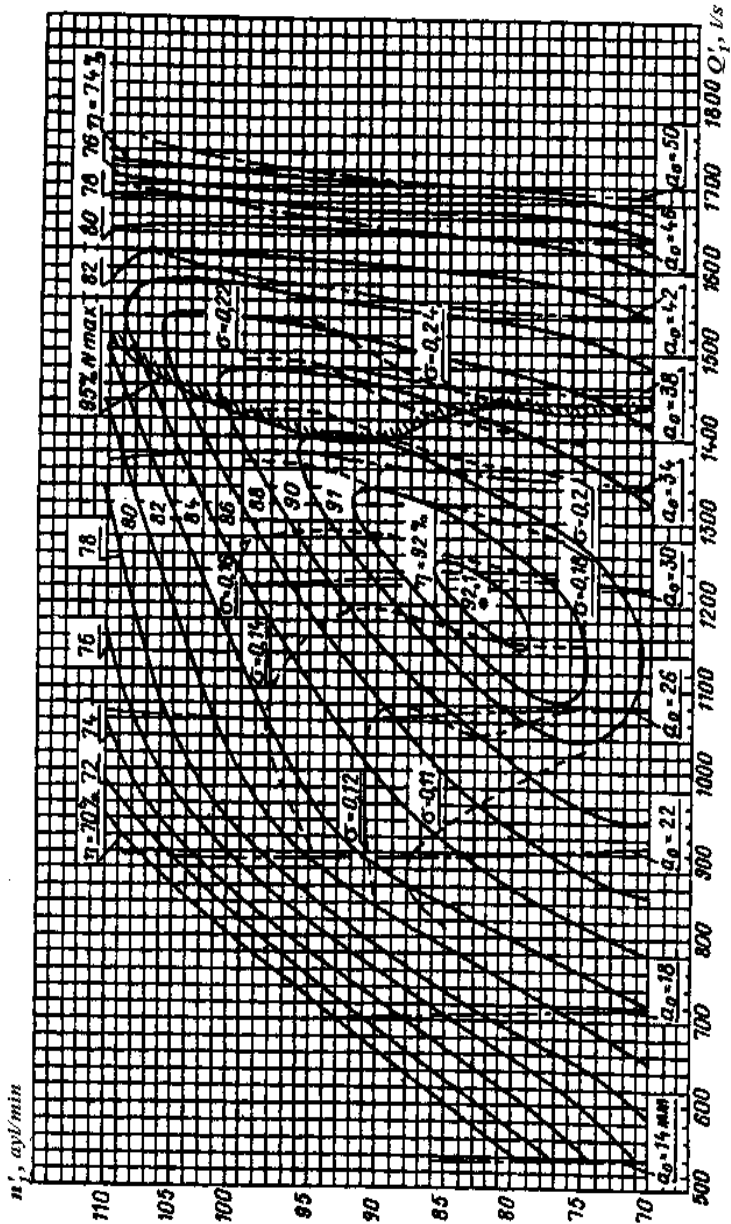

10- rasm. RO'45/820-46 turbina ishchi g'ildiragining bosh universal xarakteristikasi

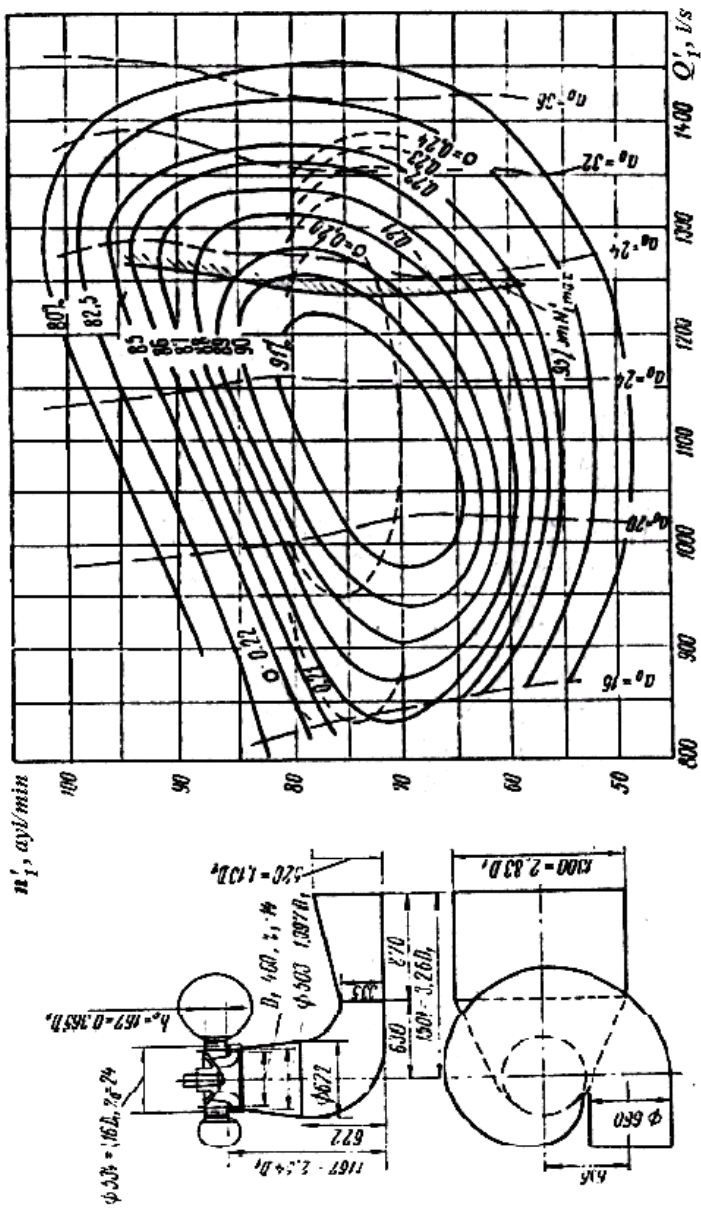

11- rasm. RO'45/123 turbina ishchi g'ildiragining bosh universal xarakteristikasi

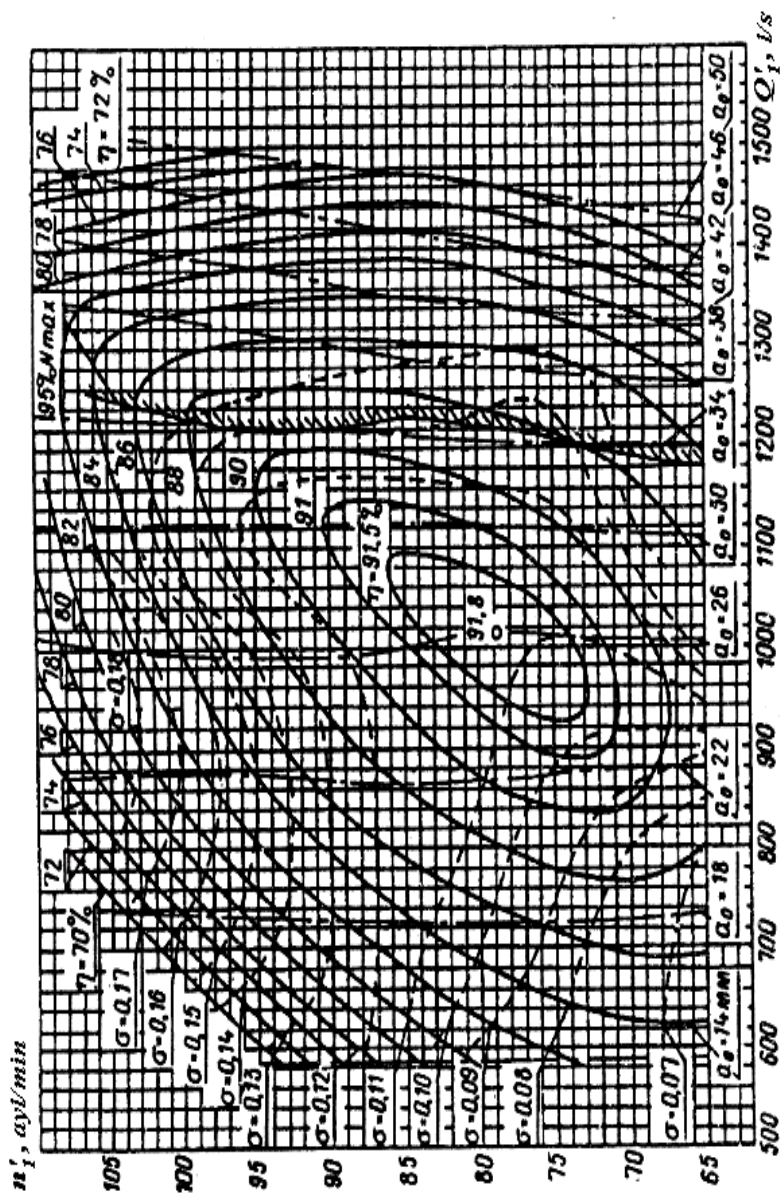

12- rasam. RO'75/7286-46 turbina ishchi g'ildiragining bosh universal xarakteristikasi

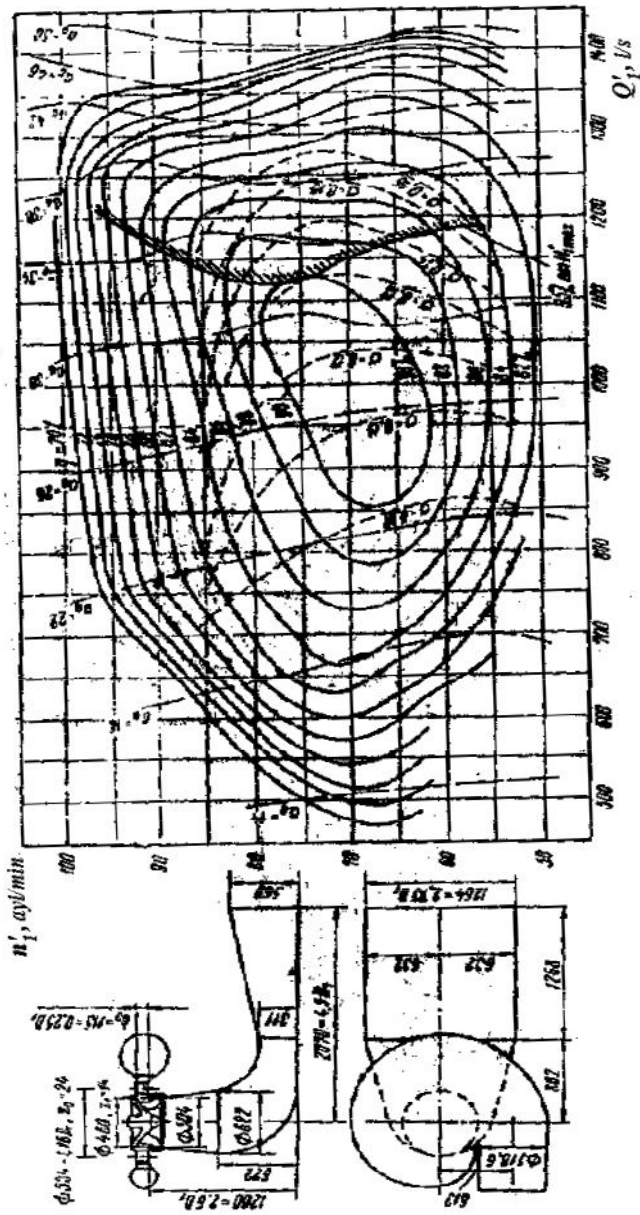

13- rasm. RO'75/702 T turbina ishchi g'ildiragining bosh universal xarakteristikasi

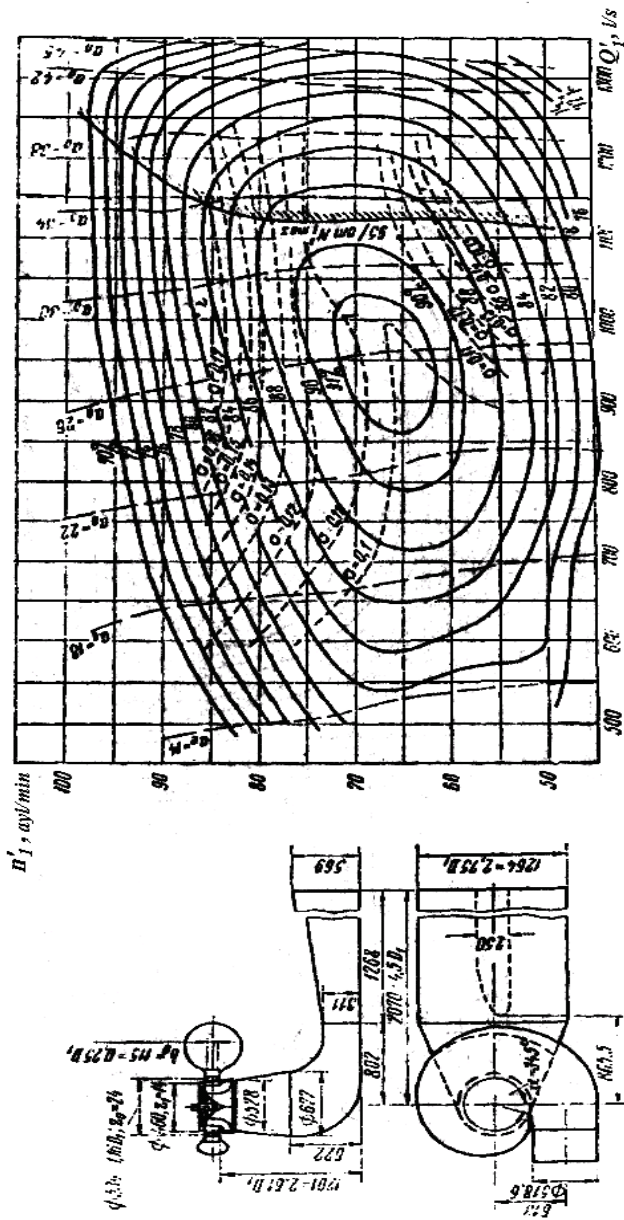

14- rasm. RO'115/697 turbina ishchi g'ildiragining bosh universal xarakteristikasi

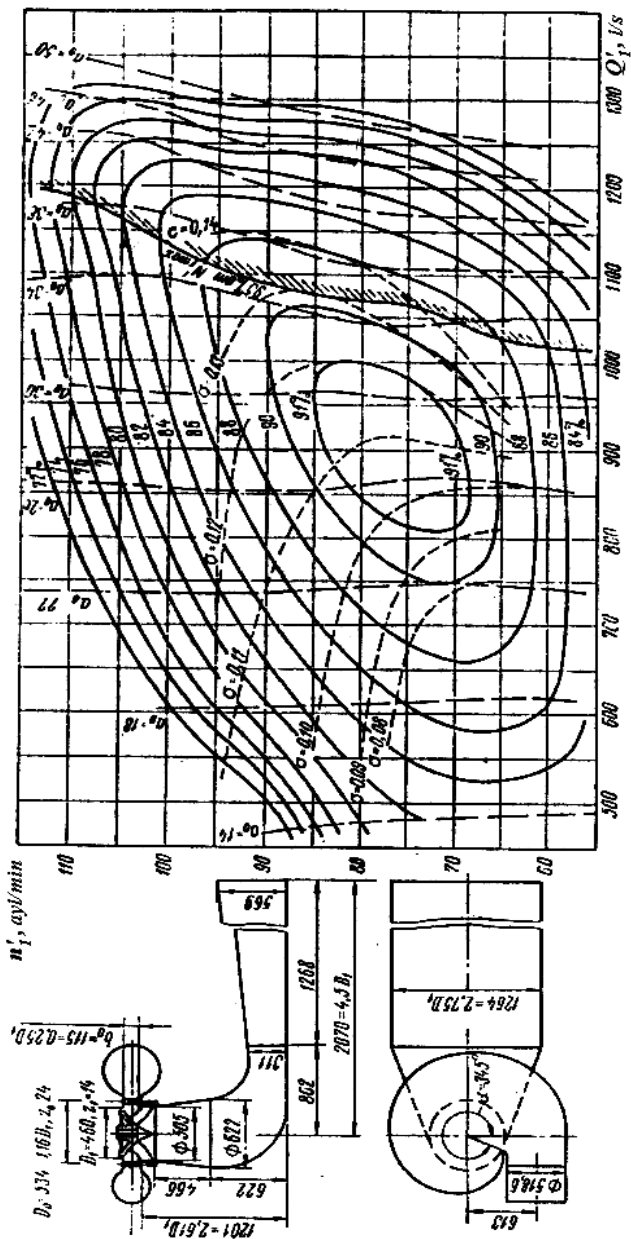

15- rasm.. RO'115/716 τ turbina ishchi g'ildiragining bosh universal xarakteristikasi

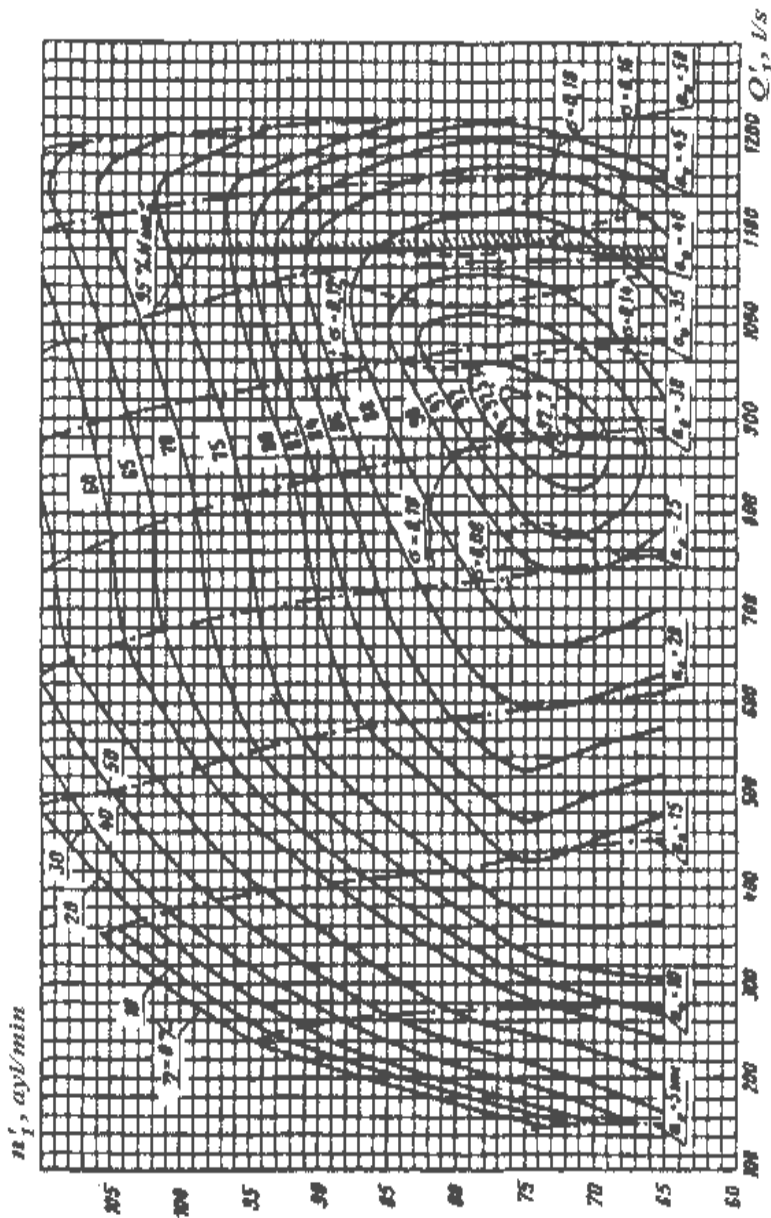

16- rasm. RO'115/810-51.56 turbina ishchi g'ildiragining bosh universal xarakteristikasi

ra

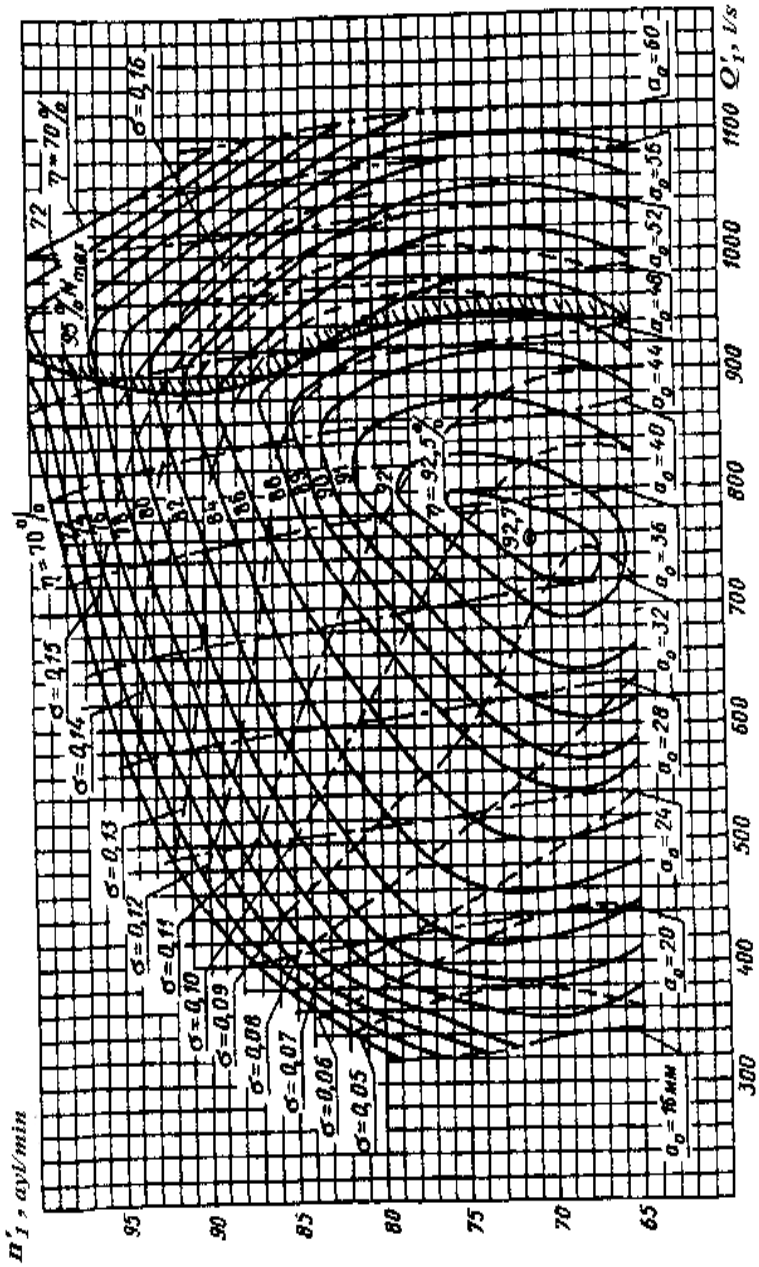

17- rasm. RO'140/8396-46 turbina ishchi g'ildiragining bosh universal xarakteristikasi

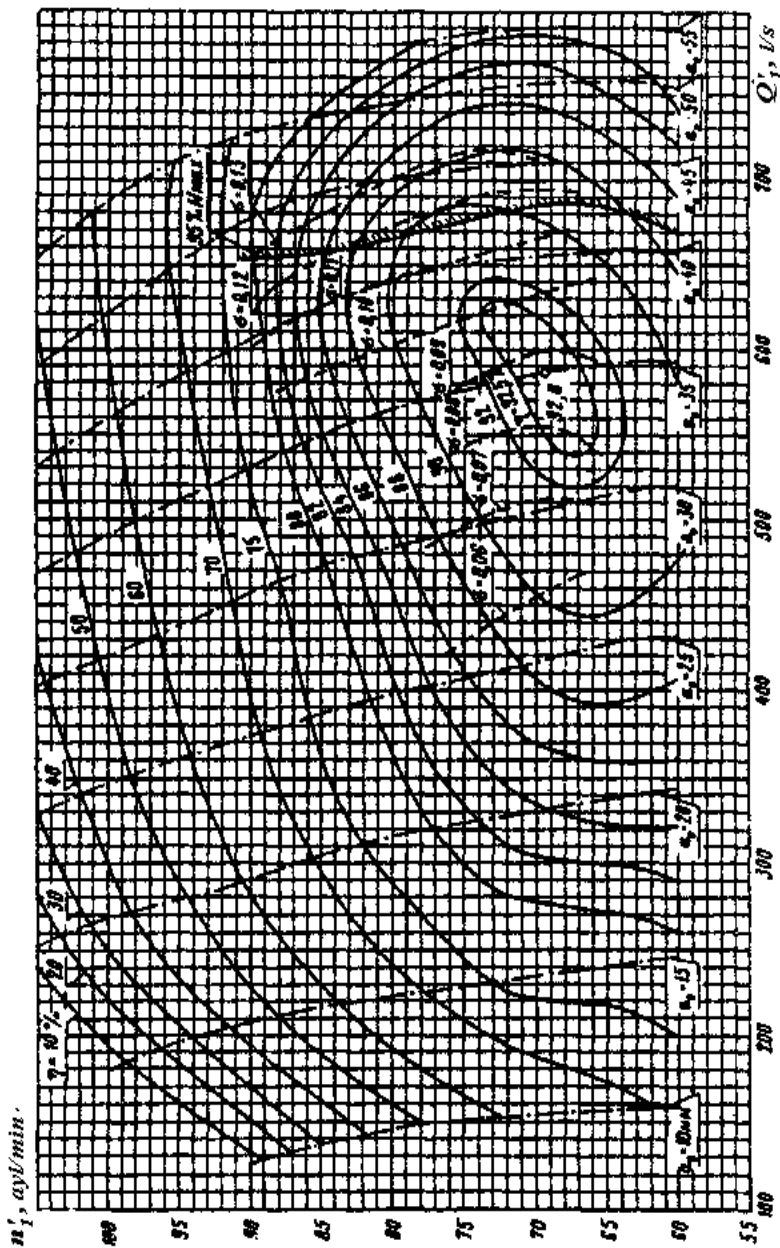

18- rasm . RO'170/805-56,87 turbina ishchi g'ildiragining bosh universal xarakteristikasi

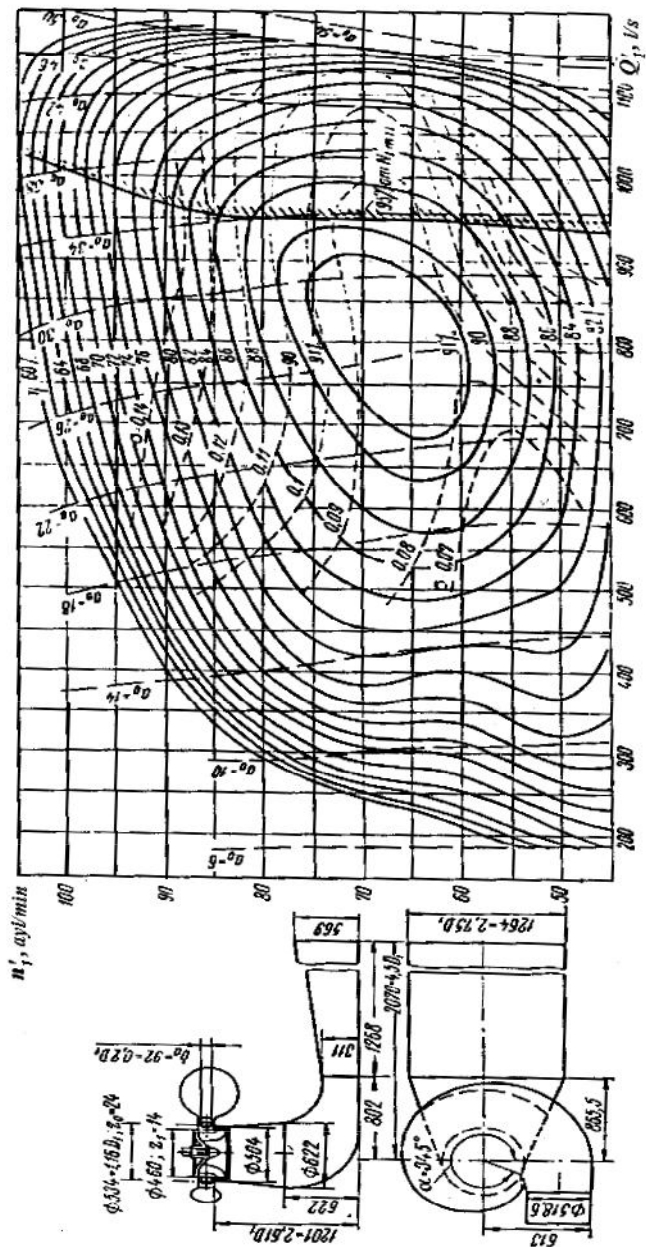

19- rasm. RO'170/741 turbina ishchi g'ildiragining bosh universal xarakteristikasi

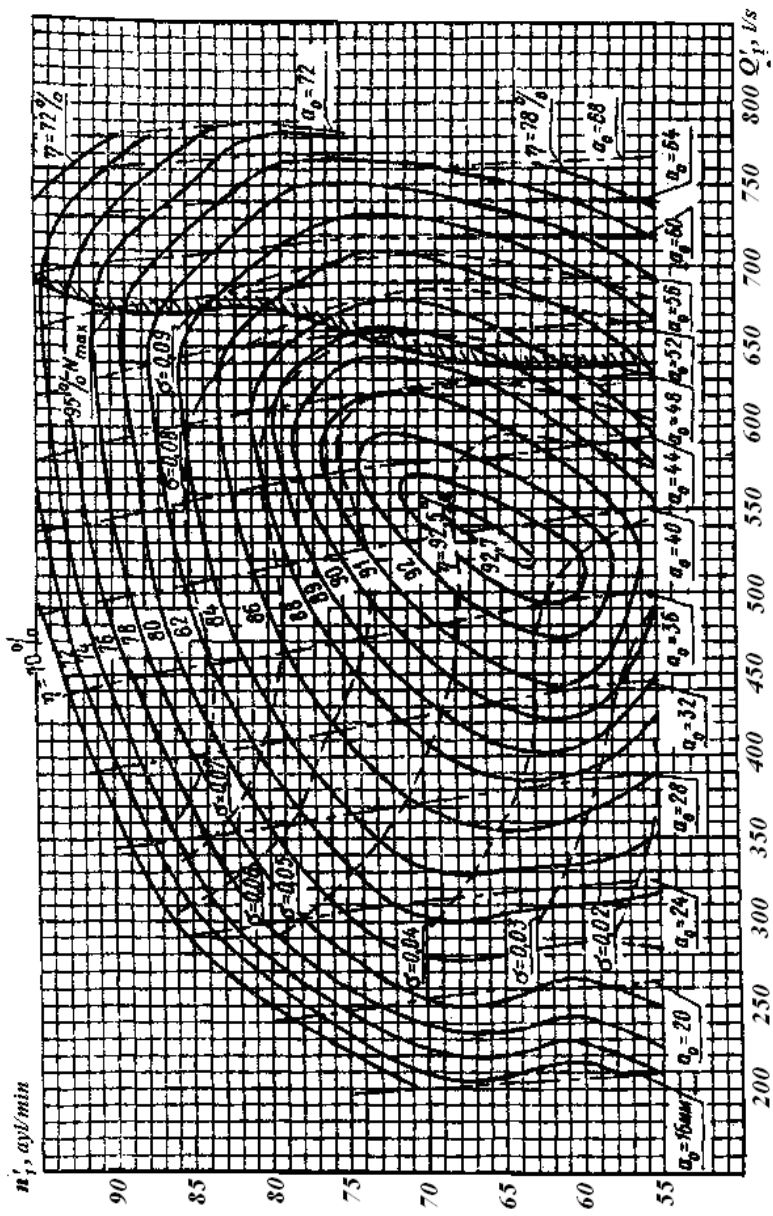

20- rasm. RO'230/791Д -62,5 turbina ishchi g'ildiragining bosh universal xarakteristikasi

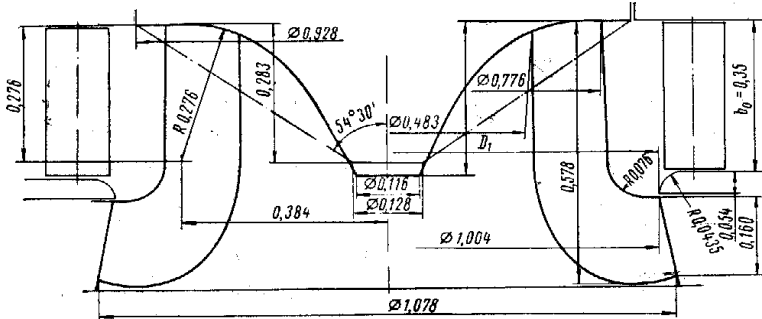

1-rasm. RO45/123 gidroturbinaning ishchi g'ildiragini suv o'tkazuvchi qismi D_1 ni ulishida

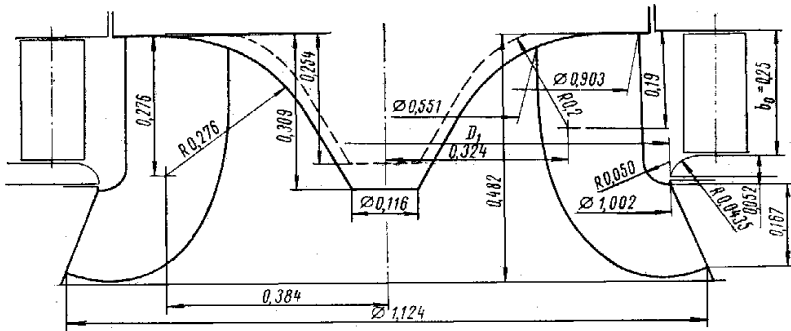

2-rasm. RO115/697 gidroturbinaning ishchi g'ildiragini suv o'tkazuvchi qismi D_1 ni ulishida

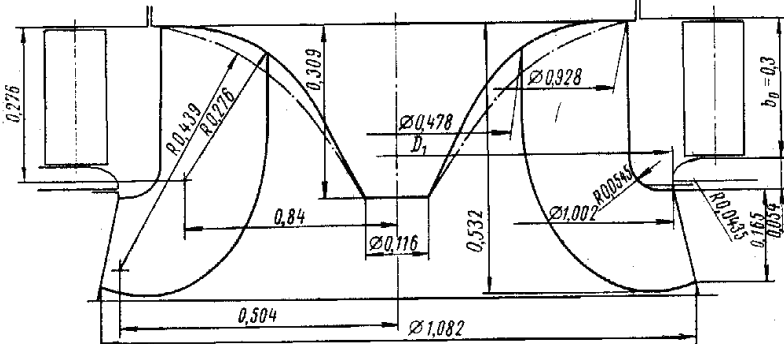

3-rasm. RO75/702 gidroturbinaning ishchi g'ildiragini suv o'tkazuvchi qismi D_1 ni ulishida

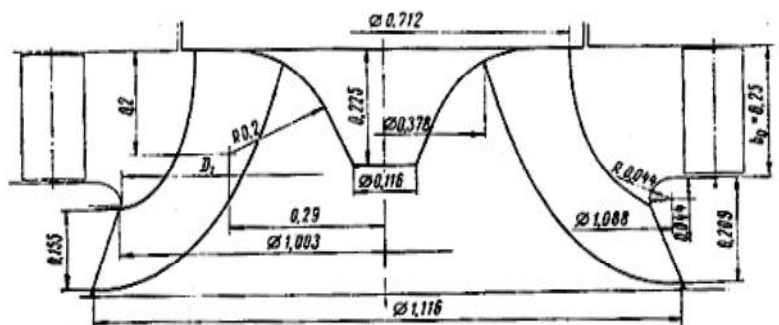

4-rasm. RO' 115/728 gidroturbinaning ishchi g'ildiragini suv o'tkazuvchi qismi D_1 ni ulishida

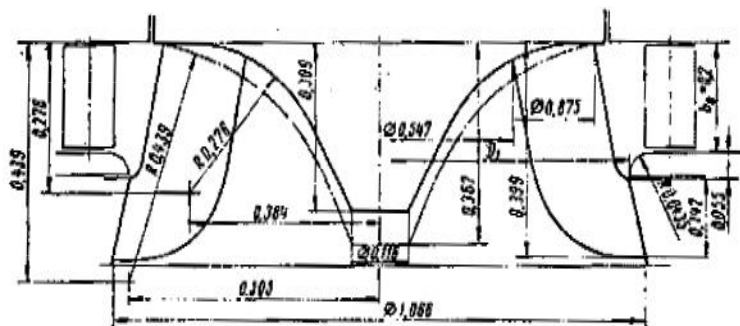

5-rasm/ RO' 170/638 gidroturbinaning ishchi g'ildiragini suv o'tkazuvchi qismi D_1 ni ulishida

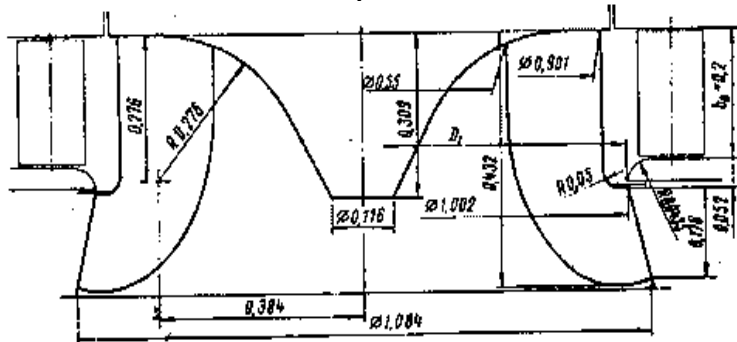

6-rasm. RO' 170/741 gidroturbinaning ishchi g'ildiragini suv o'tkazuvchi qismi D_1 ni ulishida

ADABIYOTLAR

1. Мухаммадиев М.М., Низамов О.Х. Гидротурбиналар: Ўқув қўлланма. -Тошкент, ТошДТУ, 2006.
2. Васильев Ю.С., Саморуков И.С., Хлебников С.Н. Основное энергетическое оборудование гидроэлектростанций: Учеб. пособие, Санкт-Петербург, СПбГТУ. 2002.
3. Справочник конструктора гидротурбин. /Под ред. Н.Н.Ковалева. -Л.: Машиностроение, 1971.
4. Использование водной энергии./ Под. ред.Ю.С. Васильева. -М.: Энергоатомиздат, 1995.Т.1 и 2.
5. Гидроэнергетическое и вспомогательное оборудование гидроэлектростанций./Под ред. Ю.С.Васильева и Д.С.Щавелева. - М.: Энергоатомиздат, 1988.Т.1 и 2.
6. Гидроэлектростанции малой мощности/ Под ред. В.В. Елестратова. – СПб, СПбГТУ, 2004.
7. Киселёв П.Г. Справочник по гидравлическим расчётам. - М. - Л.: Госэнергоиздат.1961, 1966.
8. Nizamov O.X. Hidroelektrostansiyalar. O‘quv qo‘llanma. T.:«Vnesh Invest Prom» nashriyoti, 2014 y.
9. <http://www.ges.ru>
10. <http://www.nasos.ru>
11. <http://www.multipumps.ru>

Muharrir: Sidiqova K.A.

Vbsahhih: Adilxodjaeva Sh.M.