

---

# ELECTRIC POWER SYSTEM BASICS

For the Nonelectrical Professional

---

**Steven W. Blume**



Mohamed E. El-Hawary, *Series Editor*



**IEEE PRESS**



WILEY-INTERSCIENCE  
A JOHN WILEY & SONS, INC., PUBLICATION



ELECTRIC POWER  
SYSTEM BASICS

**IEEE Press**  
445 Hoes Lane  
Piscataway, NJ 08854

**IEEE Press Editorial Board**  
Mohamed E. El-Hawary, *Editor in Chief*

R. Abari	T. G. Croda	R. J. Herrick
S. Basu	S. Farschi	M. S. Newman
A. Chatterjee	S. V. Kartalopoulos	N. Schulz
T. Chen	B. M. Hammerli	

Kenneth Moore, *Director of IEEE Book and Information Services (BIS)*  
Steve Welch, *Acquisitions Editor*  
Jeanne Audino, *Project Editor*

**Technical Reviewers**  
William J. Ackerman, Applied Professional Training, Inc.  
Fred Denny, McNeese State University  
Michele Wynne, Applied Professional Training, Inc./Grid Services, Inc.

### **Books in the IEEE Press Series on Power Engineering**

*Principles of Electric Machines with Power Electronic Applications*, Second Edition  
M.E. El-Hawary

*Pulse Width Modulation for Power Converters: Principles and Practice*  
D. Grahame Holmes and Thomas Lipo

*Analysis of Electric Machinery and Drive Systems*, Second Edition  
Paul C. Krause, Oleg Wasynczuk, and Scott D. Sudhoff

*Risk Assessment for Power Systems: Models, Methods, and Applications*  
Wenyuan Li

*Optimization Principles: Practical Applications to the Operations of Markets of the Electric Power Industry*  
Narayan S. Rau

*Electric Economics: Regulation and Deregulation*  
Geoffrey Rothwell and Tomas Gomez

*Electric Power Systems: Analysis and Control*  
Fabio Saccomanno

*Electrical Insulation for Rotating Machines: Design, Evaluation, Aging, Testing, and Repair*  
Greg Stone, Edward A. Boulter, Ian Culbert, and Hussein Dhirani

*Signal Processing of Power Quality Disturbances*  
Math H. J. Bollen and Irene Y. H. Gu

*Instantaneous Power Theory and Applications to Power Conditioning*  
Hirofumi Akagi, Edson H. Watanabe and Mauricio Aredes

*Maintaining Mission Critical Systems in a 24/7 Environment*  
Peter M. Curtis

*Elements of Tidal-Electric Engineering*  
Robert H. Clark

---

# ELECTRIC POWER SYSTEM BASICS

For the Nonelectrical Professional

---

**Steven W. Blume**



Mohamed E. El-Hawary, *Series Editor*



**IEEE PRESS**



WILEY-INTERSCIENCE  
A JOHN WILEY & SONS, INC., PUBLICATION

Copyright © 2007 by the Institute of Electrical and Electronics Engineers, Inc. All rights reserved.

Published by John Wiley & Sons, Inc., Hoboken, New Jersey.

Published simultaneously in Canada.

No part of this publication may be reproduced, stored in a retrieval system, or transmitted in any form or by any means, electronic, mechanical, photocopying, recording, scanning, or otherwise, except as permitted under Section 107 or 108 of the 1976 United States Copyright Act, without either the prior written permission of the Publisher, or authorization through payment of the appropriate per-copy fee to the Copyright Clearance Center, Inc., 222 Rosewood Drive, Danvers, MA 01923, (978) 750-8400, fax (978) 750-4470, or on the web at [www.copyright.com](http://www.copyright.com). Requests to the Publisher for permission should be addressed to the Permissions Department, John Wiley & Sons, Inc., 111 River Street, Hoboken, NJ 07030, (201) 748-6011, fax (201) 748-6008, or online at <http://www.wiley.com/go/permission>.

**Limit of Liability/Disclaimer of Warranty:** While the publisher and author have used their best efforts in preparing this book, they make no representations or warranties with respect to the accuracy or completeness of the contents of this book and specifically disclaim any implied warranties of merchantability or fitness for a particular purpose. No warranty may be created or extended by sales representatives or written sales materials. The advice and strategies contained herein may not be suitable for your situation. You should consult with a professional where appropriate. Neither the publisher nor author shall be liable for any loss of profit or any other commercial damages, including but not limited to special, incidental, consequential, or other damages.

For general information on our other products and services or for technical support, please contact our Customer Care Department within the United States at (800) 762-2974, outside the United States at (317) 572-3993 or fax (317) 572-4002.

Wiley also publishes its books in a variety of electronic formats. Some content that appears in print may not be available in electronic format. For information about Wiley products, visit our web site at [www.wiley.com](http://www.wiley.com).

***Library of Congress Cataloging-in-Publication Data is available.***

ISBN 978-0-470-12987-6

Printed in the United States of America.

10 9 8 7 6 5 4 3 2 1

# CONTENTS

---

Preface	ix
Acknowledgments	xiii
<b>Chapter 1 System Overview, Terminology, and Basic Concepts</b>	<b>1</b>
Chapter Objectives	1
History of Electric Power	1
System Overview	3
Terminology and Basic Concepts	3
<b>Chapter 2 Generation</b>	<b>13</b>
Chapter Objectives	13
ac Voltage Generation	14
The Three-Phase ac Generator	15
Real-Time Generation	20
Generator Connections	21
Wye and Delta Stator Connections	22
Power Plants and Prime Movers	22
<b>Chapter 3 Transmission Lines</b>	<b>47</b>
Chapter Objectives	47
Transmission Lines	47
Conductors	50
Transmission Line Design Parameters ( <i>Optional Supplementary Reading</i> )	55

Underground Transmission ( <i>Optional Supplementary Reading</i> )	57
dc Transmission Systems ( <i>Optional Supplementary Reading</i> )	57
<b>Chapter 4 Substations</b>	<b>61</b>
Chapter Objectives	61
Substation Equipment	61
Transformers	62
Regulators	73
Circuit Breakers	79
Reclosers	85
Disconnect Switches	87
Lightning Arresters	90
Electrical Bus	92
Capacitor Banks	92
Reactors	94
Static VAR Compensators	97
Control Buildings	98
Preventative Maintenance	99
<b>Chapter 5 Distribution</b>	<b>101</b>
Chapter Objectives	101
Distribution Systems	101
Transformer Connections ( <i>Optional Supplementary Reading</i> )	113
Fuses and Cutouts	121
Riser or Dip Pole	122
Underground Service	123
<b>Chapter 6 Consumption</b>	<b>133</b>
Chapter Objectives	133
Electrical Energy Consumption	134
Power System Efficiency	136
Power Factor	138
Supply and Demand	139
Demand-Side Management	139
Metering	141
Performance-Based Rates	145
Service-Entrance Equipment	147
<b>Chapter 7 System Protection</b>	<b>161</b>
Chapter Objectives	161
Two Types of Protection	161



System-Protection Equipment and Concepts	162
Distribution Protection	167
Transmission Protection	170
Substation Protection	173
Generator Protection	174
Generator Synchronization	175
Overall Transmission Protection	178
<b>Chapter 8 Interconnected Power Systems</b>	<b>179</b>
Chapter Objectives	179
Interconnected Power Systems	180
The North American Power Grids	180
Regulatory Environment	181
Interchange Scheduling	184
Interconnected System Operations	186
System Demand and Generator Loading	192
Reliable Grid Operations	195
<b>Chapter 9 System Control Centers and Telecommunications</b>	<b>203</b>
Chapter Objectives	203
Electric System Control Centers	203
Supervisory Control and Data Acquisition (SCADA)	205
Energy Management Systems	208
Telecommunications	211
<b>Chapter 10 Personal Protection (Safety)</b>	<b>221</b>
Chapter Objectives	221
Electrical Safety	221
Personal Protection	222
<b>Appendix</b>	<b>233</b>
Appendix A <i>The Derivation of Root Mean Squared</i>	233
Appendix B <i>Graphical Power Factor Analysis</i>	234
<b>Index</b>	<b>237</b>



# PREFACE

---

## **ABOUT THE BOOK**

This book is intended to give nonelectrical professionals a fundamental understanding of large, interconnected electrical power systems with regard to terminology, electrical concepts, design considerations, construction practices, industry standards, control room operations for both normal and emergency conditions, maintenance, consumption, telecommunications, and safety. Several practical examples, photographs, drawings, and illustrations are provided to help the reader gain a fundamental understanding of electric power systems. The goal of this book is to have the nonelectrical professional come away with an in-depth understanding of how power systems work, from electrical generation to household wiring and consumption by connected appliances.

This book starts with terminology and basic electrical concepts used in the industry, then progresses through generation, transmission, and distribution of electrical power. The reader is exposed to all the important aspects of an interconnected power system. Other topics discussed include energy management, conservation of electrical energy, consumption characteristics, and regulatory aspects to help readers understand modern electric power systems in order to effectively communicate with seasoned engineers, equipment manufacturers, field personnel, regulatory officials, lobbyists, politicians, lawyers, and others working in the electrical industry.

## CHAPTER SUMMARIES

A brief overview of each chapter is presented here because knowing where and when to expect specific topics and knowing how the information is organized in this book will help the reader comprehend the material easier. The language used reflects actual industry terminology.

Chapter 1 provides a brief yet informative discussion of the history that led to the power systems we know today. Then a system overview diagram with a brief discussion of the major divisions within an electric power system is provided. Basic definitions and common terminology are discussed such as voltage, current, power, and energy. Fundamental concepts such as direct and alternating current (i.e., dc and ac), single-phase and three-phase generation, types of loads, and power system efficiency are discussed in order to set the stage for more advanced learning.

Some very basic electrical formulas are presented in Chapter 1 and at times elsewhere in the book. This is done intentionally to help explain terminology and concepts associated with electric power systems. The reader should not be too intimidated or concerned about the math; it is meant to describe and explain relationships.

Basic concepts of generation are presented in Chapter 2. These concepts include the physical laws that enable motors and generators to work, the prime movers associated with spinning the rotors of the different types of generators, and the major components associated with electric power generation. The physical laws presented in this chapter serve as the foundation of all electric power systems. Throughout this book, the electrical principles identified in this chapter are carried through to develop a full-fledged electric power system.

Once the fundamentals of generation are discussed, the different prime movers used to rotate generator shafts in power plants are described. The prime movers discussed include steam, hydro, and wind turbines. Some of the nonrotating electric energy sources are also discussed, such as solar voltaic systems. The basic environmental issues associated with each prime mover are mentioned.

The major equipment components associated with each type of power plant are discussed, such as boilers, cooling towers, boiler feed pumps, and high- and low-pressure systems. The reader should gain a basic understanding of power plant fundamentals as they relate to electric power system generation.

The reasons for using very high voltage power lines compared to low-voltage power lines are explained in Chapter 3. The fundamental components of

transmission lines such as conductors, insulators, air gaps, and shielding are discussed. Direct current (dc) transmission and alternating current (ac) transmission lines are compared along with underground versus overhead transmission. The reader will come away with a good understanding of transmission line design parameters and the benefits of using high-voltage transmission for efficient transport of electrical power.

Chapter 4 covers the equipment found in substations that transform very high voltage electrical energy into a more useable form for distribution and consumption. The equipment itself (i.e., transformers, circuit breakers, disconnect switches, regulators, etc.) and their relationship to system protection, maintenance operations, and system control operations will be discussed.

Chapter 5 describes how primary distribution systems, both overhead and underground, are designed, operated, and used to serve residential, commercial, and industrial consumers. The distribution system between the substation and the consumer's demarcation point (i.e., service entrance equipment) will be the focus. Overhead and underground line configurations, voltage classifications, and common equipment used in distribution systems are covered. The reader will learn how distribution systems are designed and built to provide reliable electrical power to the end users.

The equipment located between the customer service entrance equipment (i.e., the demarcation point) and the actual loads (consumption devices) themselves are discussed in Chapter 6. The equipment used to connect residential, commercial, and industrial loads are also discussed. Emergency generators and Uninterruptible Power Supply (UPS) systems are discussed along with the issues, problems, and solutions that pertain to large power consumers.

The difference between "system protection" and "personal protection" (i.e., safety) is explained first in Chapter 7, which is devoted to "system protection": how electric power systems are protected against equipment failures, lightning strikes, inadvertent operations, and other events that cause system disturbances. "Personal protection" is discussed in Chapter 10.

Reliable service is dependant upon properly designed and periodically tested protective relay systems. These systems, and their protective relays, are explained for transmission lines, substations, and distribution lines. The reader learns how the entire electric power system is designed to protect itself.

Chapter 8 starts out with a discussion of the three major power grids in North America and how these grids are territorially divided, operated, controlled, and regulated. The emphasis is on explaining how the individual

power companies are interconnected to improve the overall performance, reliability, stability, and security of the entire power grid. Other topics discussed include generation/load balance, resource planning and operational limitations under normal and emergency conditions. Finally, the concepts of rolling blackouts, brownouts, load shedding, and other service reliability problems are discussed as are the methods used to minimize outages.

System control centers, the subject of Chapter 9, are extremely important in the day-to-day operation of electric power systems. This chapter explains how system control center operators monitor and use advanced computer programs and electronic telecommunications systems to control the equipment located in substations, out on power lines, and the actual consumer sites. These tools enable power system operators to economically dispatch power, meet system energy demands, and control equipment during normal and emergency maintenance activities. The explanation and use of SCADA (Supervisory Control and Data Acquisition) and EMS (Energy Management Systems) are included in this chapter.

The functionality and benefits of the various types of communications systems used to connect system control centers with remote terminal units are discussed. These telecommunications systems include fiber optics, microwave, powerline carrier, radio, and copper wireline circuits. The methods used to provide high-speed protective relaying, customer service call centers, and digital data/voice/video communications services are all discussed in a fundamental way.

The book concludes with Chapter 10, which is devoted to electrical safety: personal protection and safe working procedures in and around electric power systems. Personal protective equipment such as rubber insulation products and the equipment necessary for effective grounding are described. Common safety procedures and proper safety methods are discussed. The understanding of “Ground Potential Rise,” “Touch Potential,” and “Step Potential” adds a strong message as to the proper precautions needed around power lines, substations, and even around the home.

Please note that some sections within most chapters elaborate on certain concepts by providing additional detail or background. These sections are marked “optional supplementary reading” and may be skipped without losing value.

STEVEN W. BLUME

*Carlsbad, California*  
*May 2007*

# ACKNOWLEDGMENTS

---

I would personally like to thank several people who have contributed to the success of my career and the success of this book. To my wife Maureen, who has been supporting me for more than 40 years, thank you for your guidance, understanding, encouragement, and so much more. Thank you Michele Wynne; your enthusiasm, organizational skills, and creative ideas are greatly appreciated. Thank you Bill Ackerman; you are a great go-to person for technical answers and courseware development and you always display professionalism and responsibility. Thank you John McDonald; your encouragement, vision, and recognition are greatly appreciated.

S. W. B.





---

# SYSTEM OVERVIEW, TERMINOLOGY, AND BASIC CONCEPTS

---

## CHAPTER OBJECTIVES

- ✓ *Discuss the history of electricity*
- ✓ *Present a basic overview of today's electric power system*
- ✓ *Discuss general terminology and basic concepts used in the power industry*
- ✓ *Explain the key terms voltage, current, power, and energy*
- ✓ *Discuss the nature of electricity and terminology relationships*
- ✓ *Describe the three types of consumption loads and their characteristics*

## HISTORY OF ELECTRIC POWER

Benjamin Franklin is known for his discovery of electricity. Born in 1706, he began studying electricity in the early 1750s. His observations, including his kite experiment, verified the nature of electricity. He knew that lightning was very powerful and dangerous. The famous 1752 kite experiment featured a pointed metal piece on the top of the kite and a metal key at the base

end of the kite string. The string went through the key and attached to a Leyden jar. (A Leyden jar consists of two metal conductors separated by an insulator.) He held the string with a short section of dry silk as insulation from the lightning energy. He then flew the kite in a thunderstorm. He first noticed that some loose strands of the hemp string stood erect, avoiding one another. (Hemp is a perennial American plant used in rope making by the Indians.) He proceeded to touch the key with his knuckle and received a small electrical shock.

Between 1750 and 1850 there were many great discoveries in the principles of electricity and magnetism by Volta, Coulomb, Gauss, Henry, Faraday, and others. It was found that electric current produces a magnetic field and that a moving magnetic field produces electricity in a wire. This led to many inventions such as the battery (1800), generator (1831), electric motor (1831), telegraph (1837), and telephone (1876), plus many other intriguing inventions.

In 1879, Thomas Edison invented a more efficient lightbulb, similar to those in use today. In 1882, he placed into operation the historic Pearl Street steam–electric plant and the first direct current (dc) distribution system in New York City, powering over 10,000 electric lightbulbs. By the late 1880s, power demand for electric motors required 24-hour service and dramatically raised electricity demand for transportation and other industry needs. By the end of the 1880s, small, centralized areas of electrical power distribution were sprinkled across U.S. cities. Each distribution center was limited to a service range of a few blocks because of the inefficiencies of transmitting direct current. Voltage could not be increased or decreased using direct current systems, and a way to transport power longer distances was needed.

To solve the problem of transporting electrical power over long distances, George Westinghouse developed a device called the “transformer.” The transformer allowed electrical energy to be transported over long distances efficiently. This made it possible to supply electric power to homes and businesses located far from the electric generating plants. The application of transformers required the distribution system to be of the alternating current (ac) type as opposed to direct current (dc) type.

The development of the Niagara Falls hydroelectric power plant in 1896 initiated the practice of placing electric power generating plants far from consumption areas. The Niagara plant provided electricity to Buffalo, New York, more than 20 miles away. With the Niagara plant, Westinghouse convincingly demonstrated the superiority of transporting electric power over long distances using alternating current (ac). Niagara was the first large power system to supply multiple large consumers with only one power line.

Since the early 1900s alternating current power systems began appearing throughout the United States. These power systems became interconnected to form what we know today as the three major power grids in the United States and Canada. The remainder of this chapter discusses the fundamental terms used in today's electric power systems based on this history.

## SYSTEM OVERVIEW

Electric power systems are real-time energy delivery systems. Real time means that power is generated, transported, and supplied the moment you turn on the light switch. Electric power systems are not storage systems like water systems and gas systems. Instead, generators produce the energy as the demand calls for it.

Figure 1-1 shows the basic building blocks of an electric power system. The system starts with *generation*, by which electrical energy is produced in the power plant and then transformed in the power station to high-voltage electrical energy that is more suitable for efficient long-distance transportation. The power plants transform other sources of energy in the process of producing electrical energy. For example, heat, mechanical, hydraulic, chemical, solar, wind, geothermal, nuclear, and other energy sources are used in the production of electrical energy. High-voltage (HV) power lines in the *transmission* portion of the electric power system efficiently transport electrical energy over long distances to the consumption locations. Finally, substations transform this HV electrical energy into lower-voltage energy that is transmitted over distribution power lines that are more suitable for the *distribution* of electrical energy to its destination, where it is again transformed for residential, commercial, and industrial consumption.

A full-scale actual interconnected electric power system is much more complex than that shown in Figure 1-1; however the basic principles, concepts, theories, and terminologies are all the same. We will start with the basics and add complexity as we progress through the material.

## TERMINOLOGY AND BASIC CONCEPTS

Let us start with building a good understanding of the basic terms and concepts most often used by industry professionals and experts to describe and discuss electrical issues in small-to-large power systems. Please take the time necessary to grasp these basic terms and concepts. We will use them

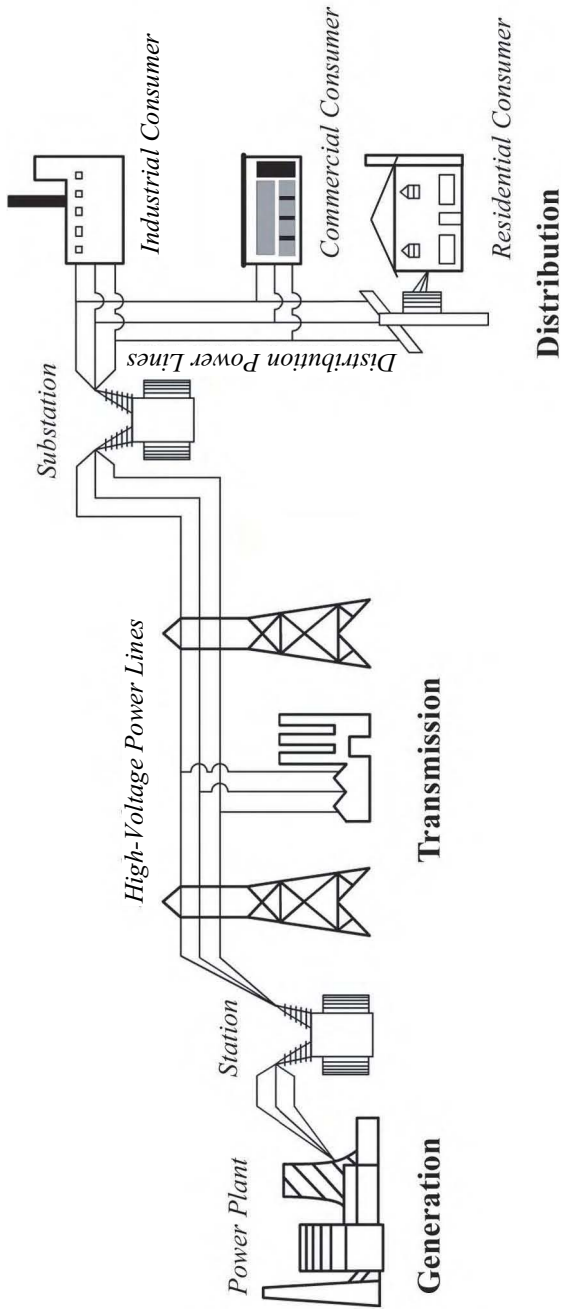

Figure 1-1. System overview.

throughout this book to build a complete working knowledge of electrical power systems.

## Voltage

The first term or concept to understand is *voltage*. Voltage is the *potential energy* source in an electrical circuit that makes things happen. It is sometimes called *Electromotive Force* or EMF. The basic unit (measurement) of electromotive force (EMF) is the *volt*. The volt was named in honor of Alessandro Giuseppe Antonio Anastasio Volta (1745–1827), the Italian physicist who also invented the battery. Electrical voltage is identified by the symbol “e” or “E.” (Some references use symbols “v” or “V.”)

Voltage is the electric power system’s potential energy source. Voltage does nothing by itself but has the potential to do work. Voltage is a push or a force. Voltage always appears between two points.

Normally, voltage is either constant (i.e., direct) or alternating. Electric power systems are based on alternating voltage applications from low-voltage 120 volt residential systems to ultra high voltage 765,000 volt transmission systems. There are lower and higher voltage applications involved in electric power systems, but this is the range commonly used to cover generation through distribution and consumption.

In water systems, voltage corresponds to the pressure that pushes water through a pipe. The pressure is present even though no water is flowing.

## Current

Current is the flow of electrons in a *conductor* (wire). Electrons are pushed and pulled by voltage through an *electrical circuit* or closed-loop path. The electrons flowing in a conductor always return to their voltage source. Current is measured in *amperes*, usually called *amps*. (One amp is equal to  $628 \times 10^{16}$  electrons flowing in the conductor per second.) The number of electrons never decreases in a loop or circuit. The flow of electrons in a conductor produces heat due to the conductor’s *resistance* (i.e., friction).

Voltage always tries to push or pull current. Therefore, when a complete circuit or closed-loop path is provided, voltage will cause current to flow. The resistance in the circuit will reduce the amount of current flow and will cause heat to be provided. The *potential energy* of the voltage source is thereby converted into *kinetic energy* as the electrons flow. The kinetic energy is then utilized by the load (i.e., consumption device) and converted into useful work.

Current flow in a conductor is similar to ping-pong balls lined up in a tube. Referring to Figure 1-2, pressure on one end of the tube (i.e., voltage)

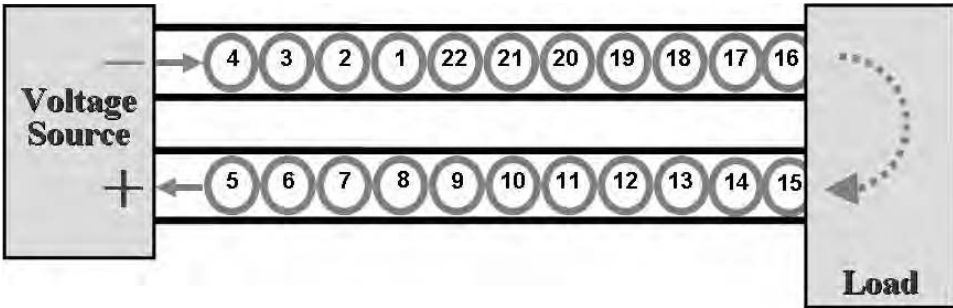

Figure 1-2. Current flow.

pushes the balls through the tube. The pressure source (i.e., battery) collects the balls exiting the tube and returns them to the tube in a circulating manner (closed-loop path). The number of balls traveling through the tube per second is analogous to current. This movement of electrons in a specified direction is called *current*. Electrical current is identified by the symbol “ $i$ ” or “ $I$ .”

### **Hole Flow Versus Electron Flow**

*Electron flow* occurs when the electron leaves the atom and moves toward the positive side of the voltage source, leaving a hole behind. The holes left behind can be thought of as a current moving toward the negative side of the voltage source. Therefore, as electrons flow in a circuit in one direction, holes are created in the same circuit that flow in the opposite direction. Current is defined as either electron flow or hole flow. *The standard convention used in electric circuits is hole flow!* One reason for this is that the concept of positive (+) and negative (-) terminals on a battery or voltage source was established long before the electron was discovered. The early experiments simply defined current flow as being from positive to negative, without really knowing what was actually moving.

One important phenomenon of current flowing in a wire that we will discuss in more detail later is the fact that *a current flowing in a conductor produces a magnetic field*. (See Figure 1-3.) This is a physical law, similar to gravity being a physical law. For now, just keep in mind that when electrons are pushed or pulled through a wire by voltage, a magnetic field is produced automatically around the wire. Note: Figure 1-3 is a diagram that corresponds to the direction of conventional or hole flow current according to the “right-hand rule.”

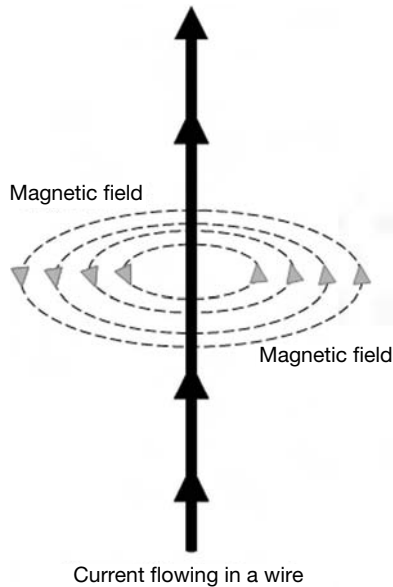

Figure 1-3. Current and magnetic field.

## Power

The basic unit (measurement) of *power* is the *watt* (W), named after James Watt (1736–1819), who also invented the steam engine. Voltage by itself does not do any real work. Current by itself does not do any real work. However, voltage and current together can produce real work. The product of voltage times current is power. Power is used to produce real work.

For example, electrical power can be used to create heat, spin motors, light lamps, and so on. The fact that power is part voltage and part current means that power equals zero if either voltage or current are zero. Voltage might appear at a wall outlet in your home and a toaster might be plugged into the outlet, but until someone turns on the toaster, no current flows, and, hence, no power occurs until the switch is turned on and current is flowing through the wires.

## Energy

Electrical *energy* is the product of electrical power and time. The amount of time a load is on (i.e., current is flowing) times the amount of power used by the load (i.e., watts) is energy. The measurement for electrical energy is *watt-hours* (Wh). The more common units of energy in electric power sys-

tems are kilowatt-hours (kWh, meaning 1,000 watt-hours) for residential applications and megawatt-hours (MWh, meaning 1,000,000 watt-hours) for large industrial applications or the power companies themselves.

### dc Voltage and Current

Direct current (dc) is the flow of electrons in a circuit that is always in the same direction. Direct current (i.e., one-direction current) occurs when the voltage is kept constant, as shown in Figure 1-4. A battery, for example, produces dc current when connected to a circuit. The electrons leave the negative terminal of the battery and move through the circuit toward the positive terminal of the battery.

### ac Voltage and Current

When the terminals of the potential energy source (i.e., voltage) alternate between positive and negative, the current flowing in the electrical circuit likewise alternates between positive and negative. Thus, alternating current (ac) occurs when the voltage source alternates.

Figure 1-5 shows the voltage increasing from zero to a positive peak value, then decreasing through zero to a negative value, and back through zero again, completing one cycle. In mathematical terms, this describes a *sine wave*. The sine wave can repeat many times in a second, minute, hour, or day. The length of time it takes to complete one cycle in a second is called the *period* of the cycle.

### Frequency

*Frequency* is the term used to describe the number of cycles in a second. The number of cycles per second is also called *hertz*, named after Heinrich

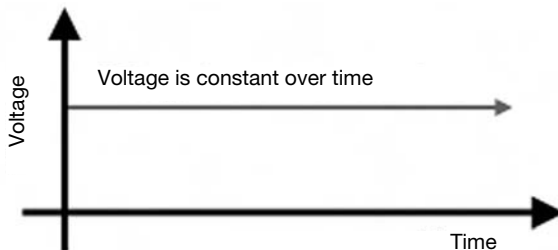

Figure 1-4. Direct current (dc voltage).



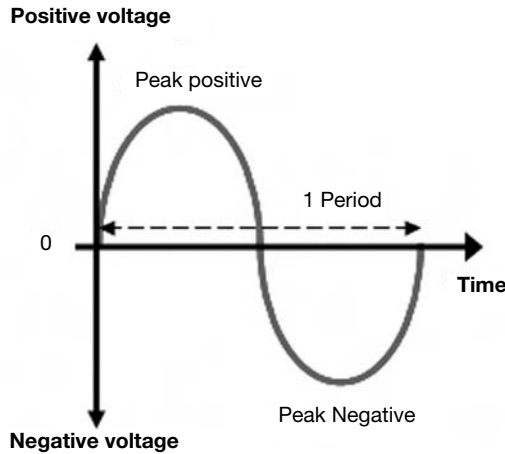

Figure 1-5. Alternating current (ac voltage).

Hertz (1857–1894), a German physicist. Note: direct current (dc) has no frequency; therefore, frequency is a term used only for ac circuits.

For electric power systems in the United States, the standard frequency is 60 cycles/second or 60 hertz. The European countries have adopted 50 hertz as the standard frequency. Countries outside the United States and Europe use 50 and/or 60 hertz. (Note: at one time the United States had 25, 50, and 60 hertz systems. These were later standardized to 60 hertz.)

## Comparing ac and dc Voltage and Current

*Electrical loads*, such as lightbulbs, toasters, and hot water heaters, can be served by either ac or dc voltage and current. However, dc voltage sources continuously supply heat in the load, whereas ac voltage sources cause heat to increase and decrease during the positive part of the cycle, then increase and decrease again in the negative part of the cycle. In ac circuits, there are actually moments of time when the voltage and current are zero and no additional heating occurs.

It is important to note that there is an equivalent ac voltage and current that will produce the same heating effect in an electrical load as if it were a dc voltage and current. The equivalent voltages and currents are referred to as the *root mean squared* values, or *rms* values. The reason this concept is important is that all electric power systems are rated in rms voltages and currents.

For example, the 120 Vac wall outlet is actually the rms value. Theoretically, one could plug a 120 Vac toaster into a 120 Vdc battery source and

cook the toast in the same amount of time. The ac rms value has the same heating capability as a dc value.

### **Optional Supplementary Reading**

Appendix A explains how rms is derived.

## **The Three Types of Electrical Loads**

Devices that are connected to the power system are referred to as electrical *loads*. Toasters, refrigerators, bug zappers, and so on are considered electrical loads. There are three types of electrical loads. They vary according to their *leading* or *lagging* time relationship between voltage and current.

The three load types are *resistive*, *inductive*, and *capacitive*. Each type has specific characteristics that make them unique. Understanding the differences between these load types will help explain how power systems can operate efficiently. Power system engineers, system operators, maintenance personnel, and others try to maximize system efficiency on a continuous basis by having a good understanding of the three types of loads. They understand how having them work together can minimize system losses, provide additional equipment capacity, and maximize system reliability.

The three different types of load are summarized below. The standard units of measurement are in parentheses and their symbols and abbreviations follow.

### **Resistive Load (Figure 1-6)**

The resistance in a wire (i.e., conductor) causes friction and reduces the amount of current flow if the voltage remains constant. Byproducts of this electrical friction are heat and light. The units (measurement) of resistance are referred to as *ohms*. The units of electrical power associated with resistive load are *watts*. Lightbulbs, toasters, electric hot water heaters, and so on are resistive loads.

Resistive  
(ohms)

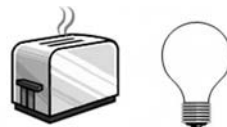
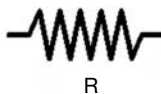

Figure 1-6. Resistive loads.

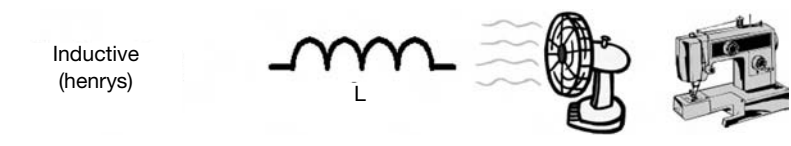

Figure 1-7. Inductive loads.

**Inductive Load (Figure 1-7)**

Inductive loads require a magnetic field to operate. All electrical loads that have a coil of wire to produce the magnetic field are called inductive loads. Examples of inductive loads are hair dryers, fans, blenders, vacuum cleaners, and many other motorized devices. In essence, all motors are inductive loads. The unique difference between inductive loads and other load types is that the current in an inductive load *lags* the applied voltage. Inductive loads take time to develop their magnetic field when the voltage is applied, so the current is delayed. The units (measurement) of inductance are called *henrys*.

Regarding electrical motors, a load placed on a spinning shaft to perform a work function draws what is referred to as *real* power (i.e., watts) from the electrical energy source. In addition to real power, what is referred to as *reactive* power is also drawn from the electrical energy source to produce the magnetic fields in the motor. The *total power* consumed by the motor is, therefore, the sum of both real and reactive power. The units of electrical power associated with reactive power are called *positive VARs*. (The acronym VAR stands for volts-amps-reactive.)

**Capacitive Load (Figure 1-8)**

A capacitor is a device made of two metal conductors separated by an insulator called a *dielectric* (i.e., air, paper, glass, and other nonconductive materials). These dielectric materials become charged when voltage is applied to the attached conductors. Capacitors can remain charged long after the

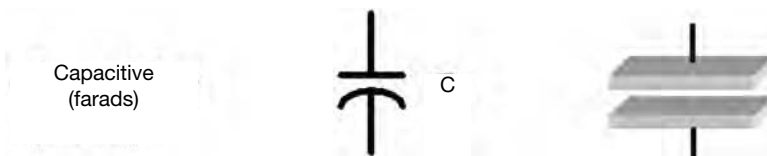

Figure 1-8. Capacitive loads.

voltage source has been removed. Examples of capacitor loads are TV picture tubes, long extension cords, and components used in electronic devices.

Opposite to inductors, the current associated with capacitors *leads* (instead of lags) the voltage because of the time it takes for the dielectric material to charge up to full voltage from the charging current. Therefore, it is said that the current in a capacitor leads the voltage. The units (measurement) of capacitance are called *farads*.

Similar to inductors, the power associated with capacitors is also called reactive power, but has the opposite polarity. Thus, inductors have positive VARs and capacitors have *negative VARs*. Note, the negative VARs of inductors can be cancelled by the positive VARs of capacitors, to leading a net zero reactive power requirement. How capacitors cancel out inductors in electrical circuits and improve system efficiency will be discussed later.

As a general rule, capacitive loads are not items that people purchase at the store in massive quantities like they do resistive and inductive loads. For that reason, power companies must install capacitors on a regular basis to maintain a reactive power balance with the inductive demand.

---

# GENERATION

---

## CHAPTER OBJECTIVES

- ✓ *Describe how voltage is produced in a conductor when in the presence of a changing magnetic field*
- ✓ *Explain how three coils of wire in the presence of a changing magnetic field produce three-phase voltage*
- ✓ *Describe how current flowing through a wire produces a magnetic field*
- ✓ *Discuss how generator rotors provide the magnetic field for the generation of electricity*
- ✓ *Describe the three main components of a generator*
- ✓ *Explain what is meant by real-time generation*
- ✓ *Discuss the two different ways to connect three generator windings symmetrically*
- ✓ *Discuss the different types of generation plants (i.e., steam, nuclear, wind, etc.)*
- ✓ *Describe the different power plant prime-mover types*

- ✓ *Discuss the conversion of mechanical energy to electrical energy*
- ✓ *Discuss how the various energy resources are converted into electrical energy*
- ✓ *Describe the environmental considerations for the different power plant types*

## ac VOLTAGE GENERATION

There are basically two physical laws that describe how electric power systems work. (Gravity is an example of a physical law.) One law has to do with generating a voltage from a changing magnetic field and the other has to do with a current flowing through a wire creating a magnetic field. Both physical laws are used throughout the entire electric power system from generation through transmission, distribution, and consumption. The combination of these two laws makes our electric power systems work. Understanding these two physical laws will enable the reader to fully understand and appreciate how electric power systems work.

### Physical Law #1

ac voltage is generated in electric power systems by a very fundamental physical law called *Faraday's Law*. Faraday's Law represents the phenomena behind how electric motors turn and how electric generators produce electricity. Faraday's Law is the foundation for electric power systems.

Faraday's Law states, "A voltage is produced on any conductor in a changing magnetic field." It may be difficult to grasp the full meaning of that statement at first. It is, however, easier to understand the meaning and significance of this statement through graphs, pictures, and animations.

In essence, this statement is saying that if one takes a coil of wire and puts it next to a moving or rotating magnet, a measurable voltage will be produced in that coil. Generators, for example, use a spinning magnet (i.e., rotor) next to a coil of wire to produce voltage. This voltage is then distributed throughout the electric power system.

We will now study how a generator works. Keep in mind that virtually all generators in service today have coils of wire mounted on stationary housings, called *stators*, where voltage is produced due to the *magnetic field* provided on the spinning *rotor*. The rotor is sometimes called the *field* because it is responsible for the magnetic field portion of the genera-

tor. The rotor's strong magnetic field passes the stator windings (coils), thus producing or generating an alternating voltage (ac) that is based on Faraday's Law. This principle will be shown and described in the following sections.

The amplitude of the generator's output voltage can be changed by changing the strength of rotor's magnetic field. Thus, the generator's output voltage can be lowered by reducing the rotor's magnetic field strength. The means by which the magnetic field in the rotor is actually changed will be discussed later in this book when Physical Law #2 is discussed.

### **Single-Phase ac Voltage Generation**

Placing a coil of wire (i.e., conductor) in the presence of a moving magnetic field produces a voltage, as discovered by Faraday. This principle is graphically presented in Figure 2-1. While reviewing the drawing, note that changing the rotor's speed changes the frequency of the sine wave. Also recognize the fact that increasing the number of turns (loops) of conductor or wire in the coil increases the resulting output voltage.

### **Three-Phase ac Voltage Generation**

When three coils are placed in the presence of a changing magnetic field, three voltages are produced. When the coils are spaced 120 degrees apart in a 360 degree circle, *three-phase* ac voltage is produced. As shown in Figure 2-2, three-phase generation can be viewed as three separate single-phase generators, each of which are displaced by 120 degrees.

## **THE THREE-PHASE ac GENERATOR**

Large and small generators that are connected to the power system have three basic components: stator, rotor, and exciter. This section discusses these three basic components.

### **The Stator**

A three-phase ac generator has three single-phase windings. These three windings are mounted on the stationary part of the generator, called the *stator*. The windings are physically spaced so that the changing magnetic field present on each winding is 120° out of phase with the other wind-

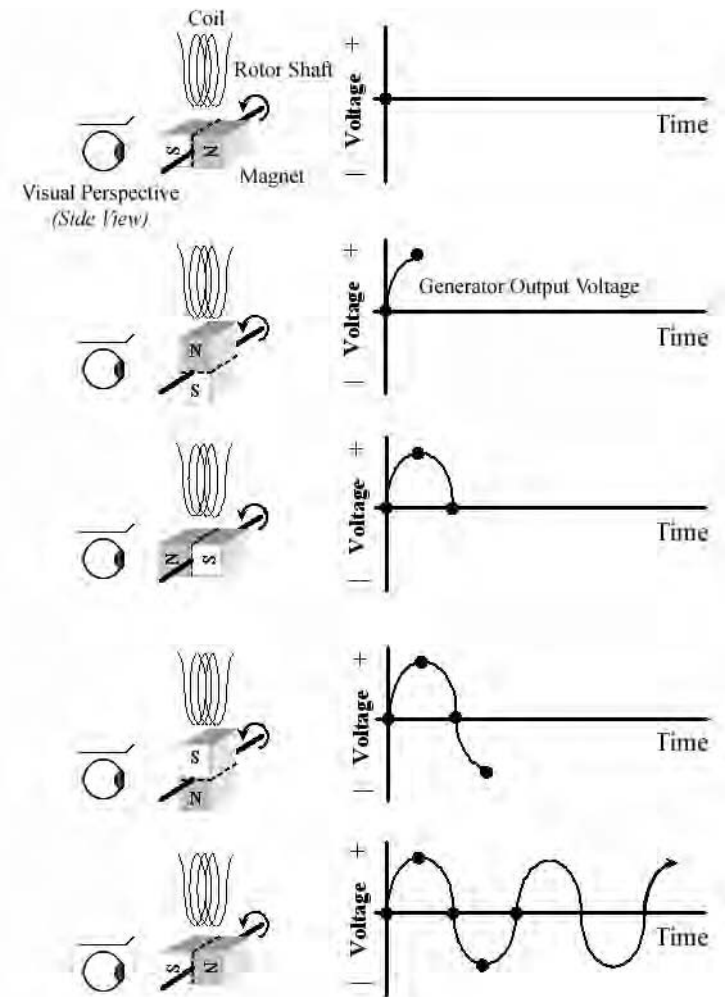

Figure 2-1. Magnetic sine wave.

ings. A simplified drawing of a three-phase generator is shown in Figure 2-3.

### The Rotor

The *rotor* is the center component that when turned moves the magnetic field. A rotor could have a permanent magnet or an *electromagnet* and still function as a generator. Large power plant generators use electromagnets so



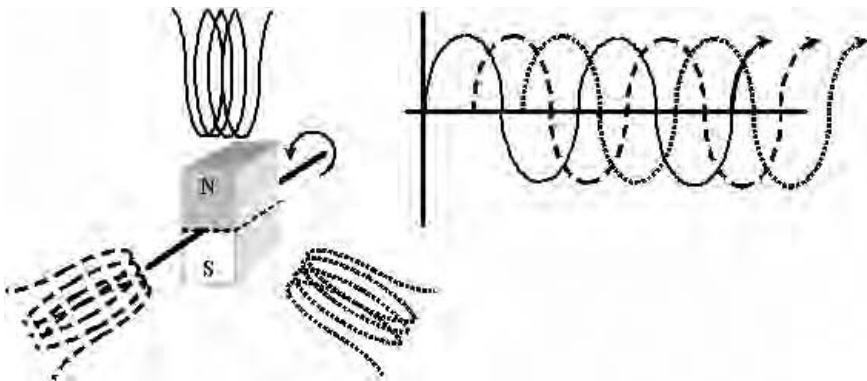

Figure 2-2. Three-phase voltage production.

that the magnetic field can be varied. Varying the magnetic field strength of the rotor enables generation control systems to adjust the output voltage according to load demand and system losses. A drawing of an electromagnet is shown in Figure 2-4.

The operation of electromagnets is described by Physical Law #2.

**Ampere’s and Lenz’s Law (Physical Law #2)**

The second basic physical law that explains how electric power systems work is the fact that current flowing in a wire produces a magnetic field. Ampere’s and Lenz’s law states that “*a current flowing in a wire produces a magnetic field around the wire.*” This law describes the relationship be-

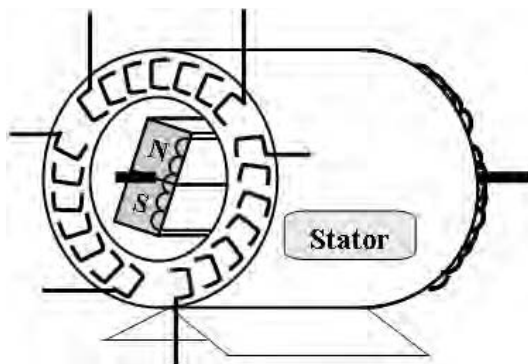

Figure 2-3. Three-phase generator—stator.

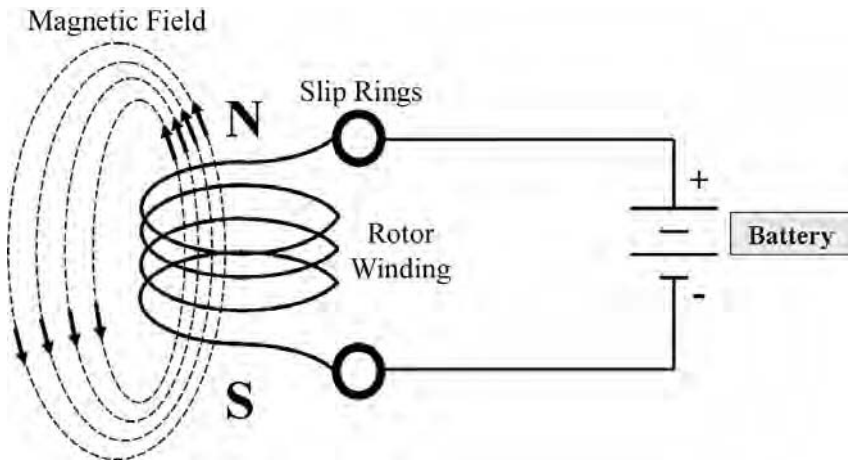

Figure 2-4. Electromagnet and slip rings.

tween the production of magnetic fields and electric current flowing in a wire. In essence, when a current flows through a wire, a magnetic field surrounds the wire.

### **Electromagnets**

Applying a voltage (e.g., battery) to a coil of wire produces a magnetic field. The coil's magnetic field will have a north and a south pole as shown in Figure 2-4. Increasing the voltage or the number of turns in the winding increases the magnetic field. Conversely, decreasing the voltage or number of turns in the winding decreases the magnetic field. *Slip rings* are electrical contacts that are used to connect the stationary battery to the rotating rotor, as shown in Figure 2-4 and Figure 2-5.

### **The Exciter**

The voltage source for the rotor, which eventually creates the rotor's magnetic field, is called the *exciter*, and the coil on the rotor is called the *field*. Figure 2-5 shows the three main components of a three-phase ac generator: the stator, rotor, and exciter.

Most generators use *slip rings* to complete the circuit between the stationary exciter voltage source and the rotating coil on the rotor where the electromagnet produces the north and south poles.

Note: Adding load to a generator's stator windings reduces rotor speed because of the repelling forces between the stator's magnetic field, and the

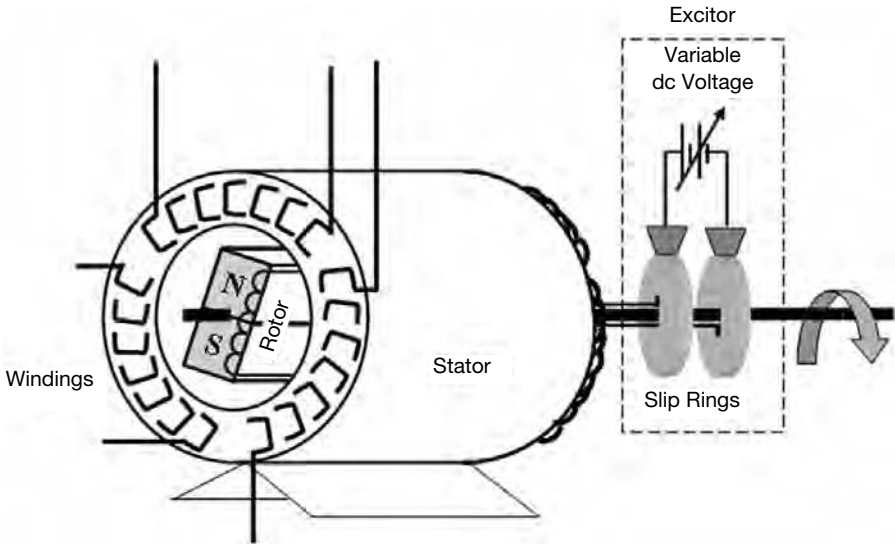

Figure 2-5. Three-phase voltage generator components.

rotor's magnetic field since both windings have electrical current flowing through them. Conversely, removing load from a generator increases rotor speed. Therefore, the mechanical energy of the prime mover that is responsible for spinning the rotor must be adjusted to maintain rotor speed or frequency under varying load conditions.

### **Rotor Poles**

Increasing the number of magnetic poles on the rotor enables rotor speeds to be slower and still maintain the same electrical output frequency. Generators that require slower rotor speeds to operate properly use multiple-pole rotors. For example, hydropower plants use generators with multiple-pole rotors because the prime mover (i.e., water) is very dense and harder to control than light-weight steam.

The relationship between the number of poles on the rotor and the speed of the shaft is determined using the following mathematical formula:

$$\text{Revolutions per minute} = \frac{7200}{\text{Number of poles}}$$

Figure 2-6 shows the concept of multiple poles in a generator rotor. Since these poles are derived from electromagnets, having multiple windings on a rotor can provide multiple poles.

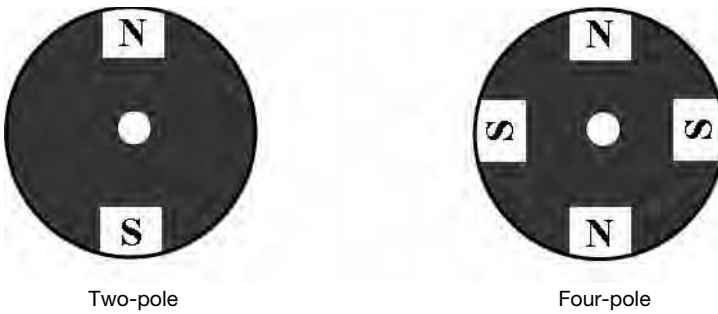

Figure 2-6. Rotor poles.

Example 1: A two pole rotor would turn at 3600 rpm for 60 hertz.

Example 2: Some of the generators at Hoover Dam near Las Vegas, Nevada, use 40-pole rotors. Therefore, the rotor speed is 180 rpm or three revolutions per second, yet the electrical frequency is 60 cycles/second (or 60 Hz). One can actually see the shaft turning at this relatively slow rotational speed.

## REAL-TIME GENERATION

Power plants produce electrical energy on a real-time basis. Electric power systems do not store energy such as most gas or water systems do. For example, when a toaster is switched on and drawing electrical energy from the system, the associated generating plants immediately see this as new load and slightly slow down. As more and more load (i.e., toasters, lights, motors, etc.) are switched on, generation output and prime mover rotational shaft energy must be increased to balance the load demand on the system. Unlike water utility systems that store water in tanks located up high on hills or tall structures to serve real-time demand, electric power systems must control generation to balance load on demand. Water is pumped into the tank when the water level in the tank is low, allowing the pumps to turn off during low and high demand periods. Electrical generation always produces electricity on an “as needed” basis. Note: some generation units can be taken off-line during light load conditions, but there must always be enough generation online to maintain frequency during light and heavy load conditions.

There are electrical energy storage systems such as batteries, but electricity found in interconnected ac power systems is in a real-time energy supply system, not an energy storage system.

## GENERATOR CONNECTIONS

There are two ways to connect three windings that have a total of six leads (the ends of the winding wires) symmetrically. The two symmetrical connection configurations of a three-phase generator (or motor) are called *delta* and *wye*. Figure 2-7 shows these two connection types. Generators usually have their stator windings connected internally in either a delta or wye configuration.

The generator *nameplate* specifies which winding configuration is used on the stator.

### Delta

Delta configurations have all three windings connected in series, as shown in Figure 2-7. The phase leads are connected to the three common points where windings are joined.

### Wye

The wye configuration connects one lead from each winding to form a common point called the *neutral*. The other three phase leads are brought out of the generator separately for external system connections. The neutral is often grounded to the station ground grid for voltage reference and stability. Grounding the neutral is discussed later.

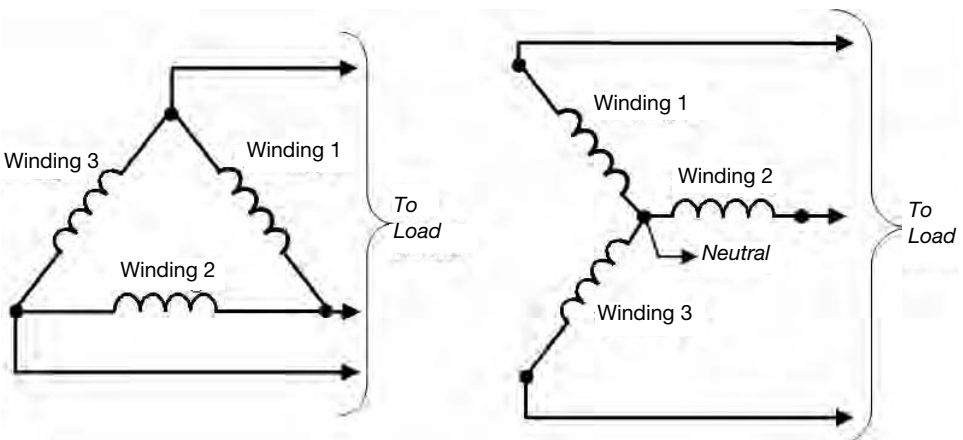

Figure 2-7. Delta and wye configurations.

### WYE AND DELTA STATOR CONNECTIONS

Electric power plant generators use either wye or delta connections. The phase leads from the generator are connected to the plant's step-up transformer (not shown yet) where the generator output voltage is increased significantly to transmission voltage levels for the efficient transportation of electrical energy. Step-up transformers are discussed later in this book. Figures 2-8 and 2-9 show both the wye and the delta generator connections.

### POWER PLANTS AND PRIME MOVERS

Power generation plants produce the electrical energy that is ultimately delivered to consumers through transmission lines, substations, and distribution lines. Generation plants or power plants consist of three-phase generator(s), the *prime mover*, energy source, control room, and substation. The generator portion has been discussed already. The prime movers and their associated energy sources are the focus of this section.

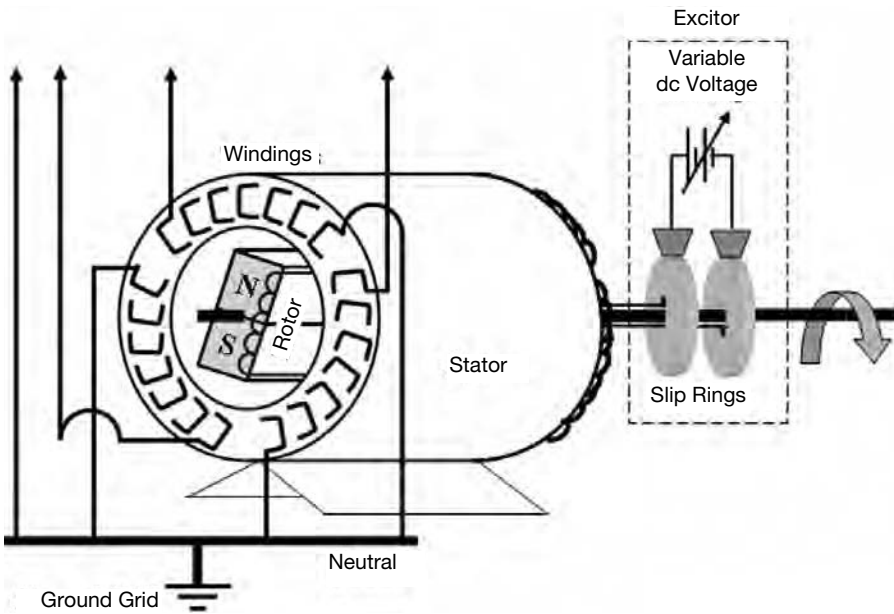

Figure 2-8. Wye connected generator.

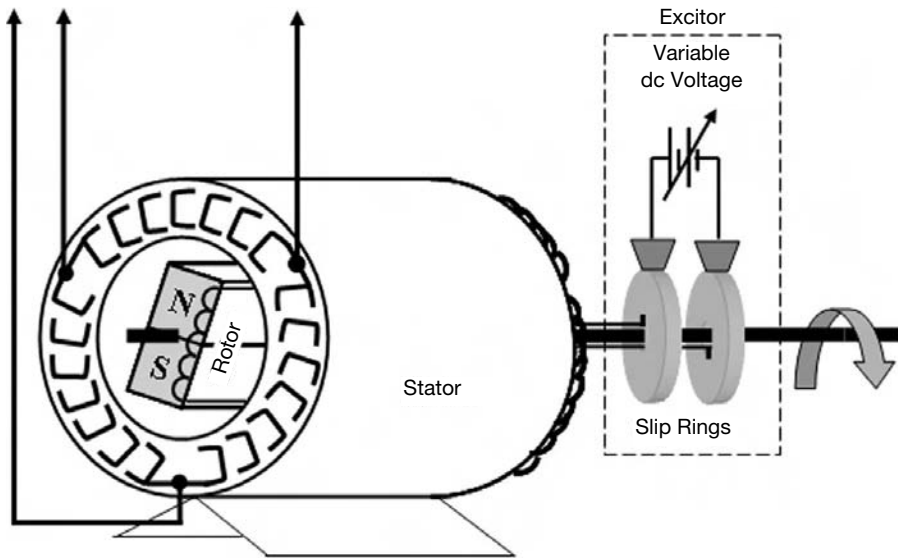

Figure 2-9. Delta-connected generator.

The mechanical means of turning the generator's rotor is called the prime mover. The prime mover's energy sources include the conversion process of raw fuel, such as coal, to the end product—steam—that will turn the turbine. The bulk of electrical energy produced in today's interconnected power systems is normally produced through a conversion process from coal, oil, natural gas, nuclear, and hydro. To a lesser degree, electrical power is produced from wind, solar, geothermal, and biomass energy resources.

The more common types of energy resources used to generate electricity and their associated prime movers that are discussed in this chapter include:

#### Steam turbines

- Fossil fuels (coal, gas, oil)
- Nuclear
- Geothermal
- Solar-heated steam

#### Hydro turbines

- Dams and rivers
- Pump storage

Combustion turbines

- Diesel
- Natural gas
- Combined cycle

Wind turbines

Solar direct (photovoltaic)

## Steam Turbine Power Plants

High-pressure and high-temperature steam is created in a boiler, furnace, or heat exchanger and moved through a *steam turbine generator* (STG) that converts the steam's energy into rotational energy that turns the generator shaft. The steam turbine's rotating shaft is directly coupled to the generator rotor. The STG shaft speed is tightly controlled for it is directly related to the frequency of the electrical power being produced.

High-temperature, high-pressure steam is used to turn steam turbines that ultimately turn the generator rotors. Temperatures on the order of 1,000°F and pressures on the order of 2,000 pounds per square inch (psi) are commonly used in large steam power plants. Steam at this pressure and temperature is called *superheated steam*, sometimes referred to as *dry steam*.

The steam's pressure and temperature drop significantly after it is applied across the *first stage* turbine blades. Turbine blades make up the fan-shaped rotor to which steam is directed, thus turning the shaft. The superheated steam is reduced in pressure and temperature after it passes through the turbine. The reduced steam can be routed through a *second stage* set of turbine blades where additional steam energy is transferred to the turbine shaft. This second stage equipment is significantly larger than the first stage to allow for additional expansion and energy transformation. In some power plants, the steam following the first stage is redirected back to the boiler where it is reheated and then sent back to the second turbine stage for a more efficient energy transformation.

Once the energy of the steam has been transferred to the turbine shaft, the low-temperature and low-pressure steam has basically exhausted its energy and must be fully *condensed* back to water before it can be recycled. The condensing process of steam back to water is accomplished by a *condenser* and *cooling tower(s)*. Once the used steam is condensed back to warm water, the *boiler feed pump* (BFP) pumps the warm water back to the boiler where it is recycled. This is a closed-loop processes. Some water has to be added in the process due to small leaks and evaporation.



The condenser takes cold water from nearby lakes, ponds, rivers, oceans, deep wells, cooling towers, and other water sources and pumps it through pipes in the condenser. The used steam passes through the relatively cold water pipes and causes dripping to occur. The droplets are collected at the base of the condenser (the well) and pumped back to the boiler by the BFP.

The overall steam generation plant efficiency in converting fuel heat energy into mechanical rotation energy and then into electrical energy ranges from 25 to 35%. Although it is a relatively low-efficiency system, steam turbine generation is very reliable and is commonly used as base load generation units in large electric power systems. Most of the inefficiency in steam turbine generation plants comes from the loss of heat into the atmosphere in the boiler process.

## **Fossil Fuel Power Plants**

Steam turbine power plants can use coal, oil, natural gas, or just about any combustible material as the fuel resource. However, each fuel type requires a unique set of accessory equipment to inject fuel into the boiler, control the burning process, vent and exhaust gases, capture unwanted byproducts, and so on.

Some fossil fuel power plants can switch fuels. For example, it is common for an oil plant to convert to natural gas when gas is less expensive than oil. Most of the time, it is not practical to convert a coal burning power plant to oil or gas unless it has been designed for conversion. The processes are usually different enough so that switching will not be cost effective.

Coal is burned in two different ways in coal fired plants. First, in traditional coal fired plants, the coal is placed on metal conveyor belts inside the boiler chamber. The coal is burned while on the belt as the belt slowly traverses the bottom of the boiler. Ash falls through the chain conveyor belt and is collected below where it is sometimes sold as a useful by-product for other industries.

In pulverized coal power plants, the coal is crushed into a fine powder and injected into the furnace where it is burned similar to a gas. Pulverized coal is mixed with air and ignited in the furnace. Combustion by-products include solid residue (ash) that is collected at the bottom of the furnace and gases that include fine ash,  $\text{NO}_2$ ,  $\text{CO}$ , and  $\text{SO}_2$ , which are emitted into the atmosphere through the stack. Depending on local environmental regulations, scrubber and baghouse equipment may be required and installed to collect most of these by-products before they reach the atmosphere.

Scrubbers are used to collect the undesirable gases to improve the quality of the stack output emissions. Baghouses are commonly used to help collect fly ash.

Some of the drawbacks that could be encountered with coal fired steam generating power plants are:

- Environmental concerns from burning coal (i.e., acid rain)
- Transportation issues regarding rail systems for coal delivery
- Length of transmission lines to remote power plant locations

Figure 2-10 shows the layout of a typical steam power plant. Notice the steam line used to transfer superheated steam from the boiler to the turbine and then through the condenser where it is returned to a water state and recycled. Notice the steam turbine connected to the generator. The turbine speed is controlled by the amount of steam applied in order to control frequency. When load picks up on the electrical system, the turbine shaft speed slows down and more steam is then placed on the turbine blades to maintain frequency. Notice how coal is delivered to the boiler and burned. Exhaust is vented through the stack. Scrubbers and bags remove the by-products before they enter the atmosphere. Water from a nearby reservoir is pumped to the condenser where it is used to convert steam back into water and recycled.

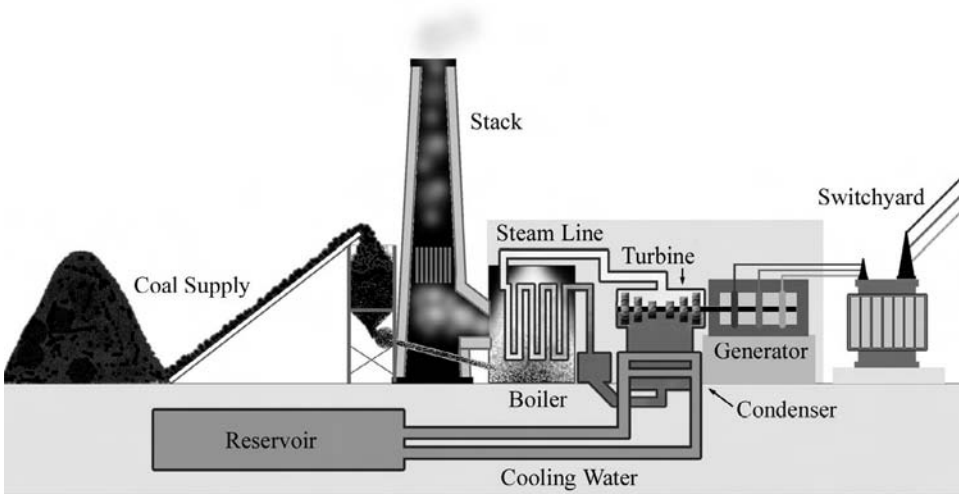

Figure 2-10. Steam power plant.

Figure 2-11 shows a coal fired steam turbine power plant. The ramp in front lifts the coal to the pulverizer where it is crushed before being injected into the boiler and burned. Plant operators must be careful to not allow the spontaneous combustion of coal while it is stored in the yard.

## Nuclear Power Plants

In nuclear power plants such as the one shown in Figure 2-12, a controlled nuclear reaction is used to make heat to produce steam needed to drive a steam turbine generator.

All nuclear plants in the United States must conform to the Nuclear Regulatory Commission's rules and regulations. Extensive documentation is required to establish that the proposed design can be operated safely without undue risk to the public. Once the Nuclear Regulatory Commission issues a license, the license holder must maintain the license and the reactor in accordance with strict rules, usually called Tech Specs. Compliance to these rules and regulations in conjunction with site inspections ensures that a safe nuclear power plant is in operation.



Figure 2-11. Coal power plant. *Source:* Fotosearch.

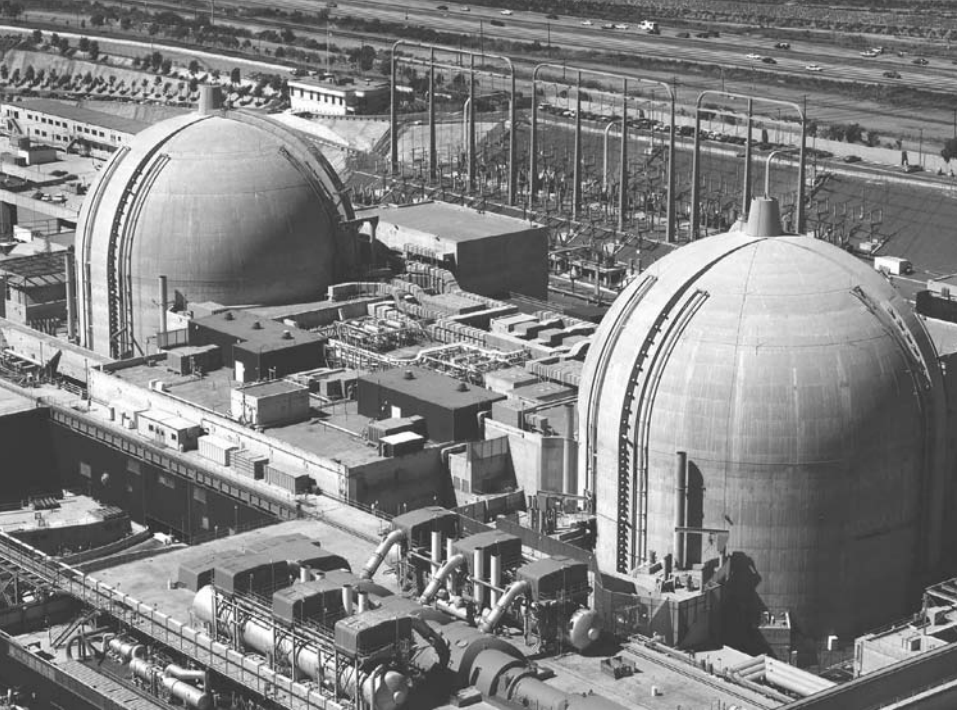

Figure 2-12. Nuclear power plant. *Source:* Fotosearch.

## ***Nuclear Energy***

Atoms are the building blocks from which all matter is formed. Everything is made up of atoms. Atoms are made up of a nucleus (with protons and neutrons) and orbiting electrons. The number of atomic particles (i.e., sum of neutrons, protons, and electrons) determines the atomic weight of the atom and type of element in the periodic table. Nuclear energy is contained within the center of atoms (i.e., nucleus) where the atom's protons and neutrons exist. Nature holds the particles within the atom's nucleus together by a very strong force. If a nucleus of a large element (such as uranium 235) is split apart into multiple nuclei of different element compositions, generous amounts of energy are released in the process. The heat emitted during this process (i.e., *nuclear reaction*) is used to produce steam energy to drive a turbine generator. This is the foundation of a nuclear power plant.

There are basically two methods used to produce nuclear energy in order to produce heat to make steam. The first process is called *fission*. Fission is

the splitting of large nuclei atoms such as uranium inside a nuclear reactor to release energy in the form of heat to be used to produce steam to drive steam turbine electrical power generators. The second process is called *fission*. Fusion is the combining of small nuclei atoms into larger ones, resulting in an accompanying release of energy. However, fusion reactors are not yet used to produce electrical power because it is difficult to overcome the natural mutual repulsion force of the positively charged protons in the nuclei of the atoms being combined.

In the fission process, certain heavy elements, such as uranium, are split when a neutron strikes them. When they split, they release energy in the form of *kinetic energy* (heat) and *radiation*. Radiation is subatomic particles or high-energy light waves emitted by unstable nuclei. The process not only produces energy and radiation, it also provides additional neutrons that can be used to fission other uranium nuclei and, in essence, start a chain reaction. The controlled release of this nuclear energy using commercial-grade fuels is the basis of electric power generation. The uncontrolled release of this nuclear energy using more highly enriched fuels is the basis for atomic bombs.

The reactor is contained inside an obvious *containment shell*. It is made up of extremely heavy concrete and dense steel in order to minimize the possibility of a reactor breach due to an accident. Nuclear power plants also have an emergency backup scheme of injecting *boron* into the reactor coolant. Boron is an element that absorbs neutrons very readily. By absorbing neutrons, the neutrons are not available to continue the nuclear reaction, and the reactor shuts down.

The most widely used design for nuclear reactors consists of a heavy steel pressure vessel surrounding the *reactor core*. The reactor core contains the uranium fuel. The fuel is formed into cylindrical ceramic pellets about one-half inch in diameter, which are sealed in long metal tubes called *fuel tubes*. The tubes are arranged in groups to make a *fuel assembly*. A group of fuel assemblies forms the *reactor core*.

Controlling the heat production in nuclear reactors is accomplished by using materials that absorb neutrons. These control materials or elements are placed among the fuel assemblies. When the control elements, or *control rods* as they are often called, are pulled out of the core, more neutrons are available and the chain reaction increases, producing more heat. When the control rods are inserted into the core, more neutrons are absorbed, and the chain reaction slows down or stops, producing no heat. The *control rod drive system* controls the actual output power of the electric power plant.

Most commercial nuclear reactors use ordinary water to remove the heat created by the fission process. These are called *light water reactors*. The

water also serves to slow down or *moderate* the neutrons in the fission process. In this type of reactor, control mechanisms are used such that the chain reaction will not occur without the water to serve as a moderator. In the United States, there are two different types of light-water reactor designs used, the *pressurized water reactor* (PWR) and the *boiling water reactor* (BWR).

**PRESSURIZED WATER REACTOR (PWR).** The basic design of a pressurized water reactor is shown in Figure 2-13. The reactor and the primary steam generator are housed inside a containment structure. The structure is designed to withstand accidental events such as small airplane crashes. The PWR steam generator separates the radioactive water that exists inside the reactor from the steam that is going to the turbine outside the shell.

In a PWR, the heat is removed from the reactor by water flowing in a closed, pressurized loop. The heat is transferred to a second water loop through a *heat exchanger* (or *steam generator*). The second loop is kept at a lower pressure, allowing the water to boil and create steam, which is used to turn the turbine generator and produce electricity. Afterward, the steam is condensed back into water and returned to the heat exchanger where it is recycled into useable steam.

The normal control of the reactor power output is by means of the control rod system. These control rods are normally inserted and controlled from the top of the reactor. Because the control rods are inserted and controlled from the top of the reactor, the design also includes special springs and re-

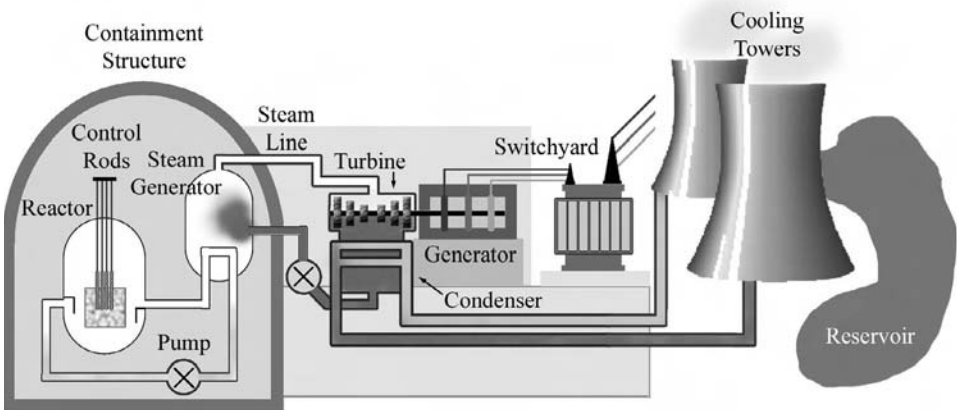

Figure 2-13. Pressurized water reactor.

lease mechanisms so that if all power is lost, the control rod will be dropped into the reactor core by gravity to shut down the reactor.

*Advantages and Disadvantages of PWR.* As with any design, there are advantages and disadvantages of pressurized water reactors. A major design advantage is the fact that fuel leaks, such as ruptured fuel rods, are isolated in the core and primary loop. That is, radioactive material contained inside the fuel is not allowed to go outside of the containment shell. The pressurized water reactor can be operated at higher temperature/pressure combinations, and this allows an increase in the efficiency of the turbine generator system.

Another advantage is that it is believed that a pressurized water reactor is more stable than other designs. This is because boiling is not allowed to take place inside the reactor vessel and, therefore, the density of the water in the reactor core is more constant. By reducing the variability of the water density, controls are somewhat simplified.

The biggest disadvantage appears to be the fact that the reactor design is more complicated. It is necessary to design for extremely high pressures and temperatures in order to ensure that boiling does not take place inside the reactor core. The use of high-pressure vessels makes the overall reactor somewhat more costly to build. Finally, under certain circumstances, the pressurized water reactor can produce power at a faster rate than the cooling water can remove heat. If this event takes place, there is a high probability of fuel rod damage.

**BOILING WATER REACTOR (BWR).** Figure 2-14 shows a boiling water reactor (BWR). Again, there is a reactor building or containment shell where the nuclear reactor and some of its complement equipment are located. The reactor housing of the BWR tends to be larger than the PWR and looks almost like an inverted lightbulb.

In a BWR, water boils inside the reactor itself, and the steam goes directly to the turbine generator to produce electricity. Similar to other steam power plants, the steam is condensed and reused. Note that the turbine building is closely coupled to the reactor building, and special constraints exist in entering the turbine building because the water can pick up radioactivity.

Note the *torus* at the bottom of the reactor. If there should be a reactor rupture, the water inside the reactor will flash into steam and create a very high pressure surge in the reactor building. The reactor torus is filled with cold water, which will instantly condense the steam. The torus system en-

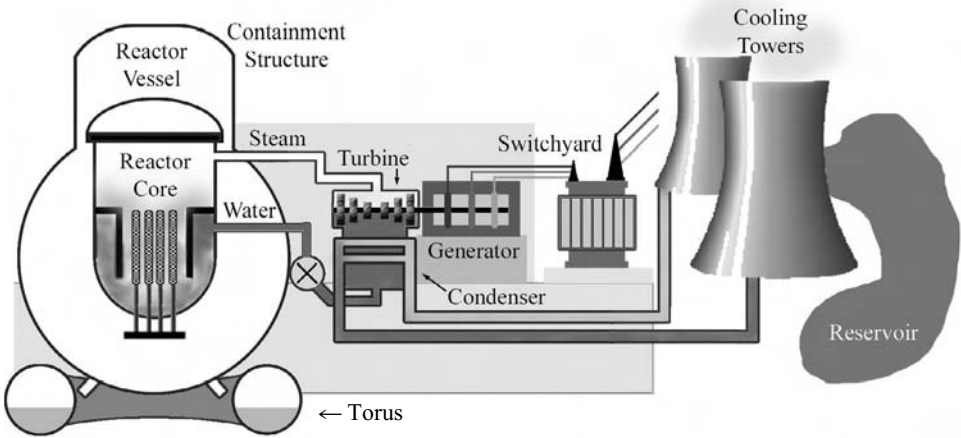

Figure 2-14. Boiling water reactor.

sure that the pressure inside the containment dome never exceeds an acceptable level.

As with the pressurized water reactor, the reactor housing contains the fuel core and water supply flow paths. The reactor recirculation system consists of the pumps and pipes that circulate the water through the reactor. The water circulating through the reactor actually goes into the turbine itself and then condensed water goes back into the reactor. The steam separator in the reactor shell separates the water from the steam and allows the steam to pass to the steam generator. The separated water is returned to the reactor for recirculation.

The boiling water reactor utilizes one cooling loop. Both water and steam exist in the reactor core (i.e., a definition of boiling). Reactor power is controlled by positioning the control rods from start-up to approximately 70% of rated power. From 70% to 100% of rated power, the reactor power is controlled by changing the flow of water through the core. As more water is pumped through the core and more steam generated, more power is produced. In the boiling water reactor, control rods are normally inserted from the bottom. The top of the reactor vessel is used to separate water and steam.

*Advantages and Disadvantages of BWR.* A major advantage of the BWR is that the overall thermal efficiency is greater than that of a pressurized water reactor because there is no separate steam generator or heat exchanger. Controlling the reactor is a little easier than in a PWR because it is accom-



plished by controlling the flow of water through the core. Increasing the water flow increases the power generated. Because of the nature of the design, the reactor vessel is subjected to less radiation, and this is considered to be an advantage because some steels become brittle with exposure to excessive radiation.

The greatest disadvantage of the BWR is that the design is much more complex. It requires a larger pressure vessel than the PWR because of the amount of steam that can be released during an accident. This larger pressure vessel also increases the cost of the BWR. Finally, the design does allow a small amount of radioactive contamination to get into the turbine system. This modest radioactivity requires that anybody working on the turbine must wear appropriate protective clothing and use the proper equipment.

### ***Other Related Topics (Optional Supplementary Reading)***

The overall function or design of the nonnuclear portion of a nuclear power plant is of the same order of complexity as a fossil fueled power plant. The biggest difference is the degree of documentation that must be maintained and submitted to the regulatory authorities for proof that the design and operation are safe. Roughly speaking, there are about 80 separate systems in a nuclear power plant. The systems that are most critical are those that control the power and/or limit the power output of the plant.

**ENVIRONMENTAL.** One of the greatest advantages of a nuclear plant, especially with today's concerns about global warming and generation of carbon dioxide due to burning, is the fact that a nuclear plant essentially adds zero emissions to the atmosphere. There is no smoke stack!

**SCRAM.** A reactor *SCRAM* is an emergency shutdown situation. Basically, all control rods are driven into the reactor core as rapidly as possible to shut down the reactor to stop heat production. A SCRAM occurs when some protective device or sensor signals the control rod drive system. Some typical protective signals that might initiate or trigger a SCRAM include a sudden change in neutron production, a sudden change in temperatures inside the reactor shell, sudden change in pressures, or other potential system malfunctions.

By inserting the control rods into the reactor core, the reactor power is slowed down and/or stopped because the control rod materials absorb neutrons. If the neutrons are absorbed, they cannot cause fission in additional uranium atoms.

Anytime there is a reactor SCRAM, the cause must be fully identified and appropriate remedial actions taken before the reactor can be restarted. Needless to say, a reactor SCRAM usually results in a great deal of paperwork to establish the fact that the reactor can be safely restarted.

There are various theories as to where the term SCRAM came from. One theory says that around the World War II era the original nuclear reactors were controlled manually. As a safety measure, the reactor was designed so that control rods would drop by gravity into the reactor core and absorb the neutrons. The control rods were held up by a rope. In case of emergency, the rope was to be cut to allow the rods to drop. The person responsible for cutting the rope in case of any emergency was called the SCRAM. According to the Nuclear Regulatory Commission, SCRAM stands for "*safety control rod axe man*." Now, SCRAM stands for any emergency shutdown of the reactor for any reason.

**EQUIPMENT VIBRATION.** Equipment vibration is probably the biggest single problem in nuclear power plants. Every individual component is monitored by a central computer system for vibration indications. If excessive vibration is detected, the system involved must be quickly shut down. (Note this is also true of regular steam plants. If excessive vibration is detected in the turbine or generator, they will be shut down.)

Nuclear power plants seem to be particularly susceptible to vibration problems, especially on the protective relay panels. Excessive vibration can cause inadvertent relay operations, shutting down a system or the complete plant.

Microprocessor-based protection relay equipment is basically immune to vibration problems, but there is a perception that the solid-state circuits used in such relays may be damaged by radiation. Most nuclear power plants still use electromechanical relays as backup to the microprocessor solid-state relays.

## **Geothermal Power Plants**

Geothermal power plants use hot water and/or steam located underground to produce electrical energy. The hot water and/or steam are brought to the surface where heat exchangers are used to produce clean steam in a secondary system for use with turbines. Clean steam causes no sediment growth inside pipes and other equipment, thereby minimizing maintenance. The clean steam is converted into electrical energy much the same way as in typical fossil fueled steam plants.

Although geothermal energy is considered to be a good renewable source of reliable power, some are concerned that over the long term, the availability of this geothermal resource for power plants may be reduced over time (i.e., it may dry up, become less available, or lose pressure). A typical geothermal power plant is shown in Figure 2-15.

## **Solar Reflective Power**

Solar power plants are environmentally friendly as they produce no pollution. Large-scale solar reflective plants require a substantial amount of area as well as specific orientation with the sun to capture the maximum energy possible with high efficiency.

Solar energy is reflected off mirrors and concentrated on a centralized boiler system. The mirrors are parabolic-shaped and motorized to focus the sun's energy toward the receiver tubes in the collector area of the elevated boiler. The receiver tubes contain a heat transfer fluid used in the steam–boiler–turbine system. The collector area housing the receiver tubes absorbs the focused sun energy to gain 30 to 100 times normal solar energy. The fluid in these tubes can reach operating temperatures in excess of 400 degrees Celsius. The steam drives the turbine and then goes through a condenser for conversion back to liquid before being reheated in the boiler system. A typical solar power plant is shown in Figure 2-16.

## **Hydroelectric Power Plants**

Hydroelectric power plants capture the energy of moving water. There are multiple ways hydro energy can be extracted. Falling water such as in a penstock, flume, or waterwheel can be used to drive a hydro turbine. Hydro energy can be extracted from water flowing at the lower section of dams, where the pressure forces water to flow. Hydroelectric power generation is efficient, cost-effective, and environmentally cooperative. Hydro power production is considered to be a renewable energy source because the water cycle is continuous and constantly recharged.

Water flows much slower through a hydro turbine than does steam through a high-pressure steam turbine. Therefore, several rotor magnetic poles are used to reduce the rotational speed requirement of the hydro turbine shaft.

Hydro units have a number of excellent advantages. The hydro unit can be started very quickly and brought up to full load in a matter of minutes. In most cases, little or no start-up power is required. A hydro plant is almost by

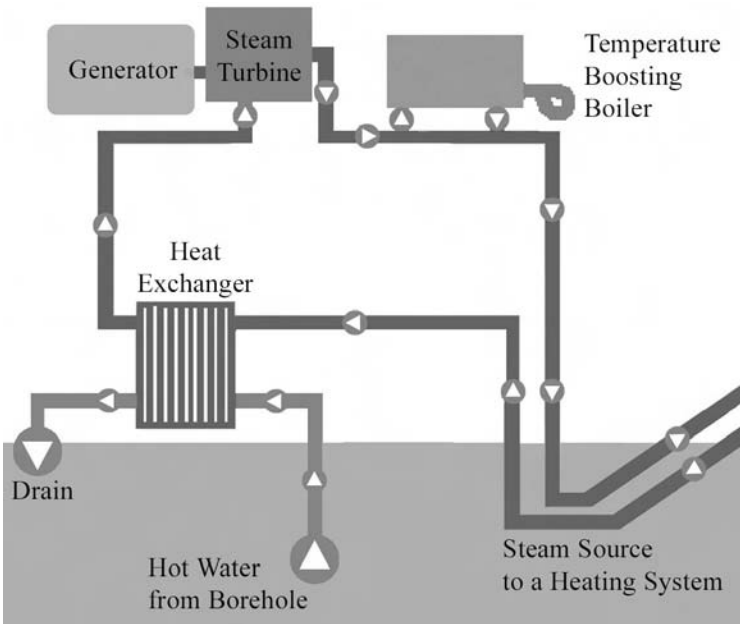

Figure 2-15. A geothermal power plant and schematic. *Source:* Fotosearch.

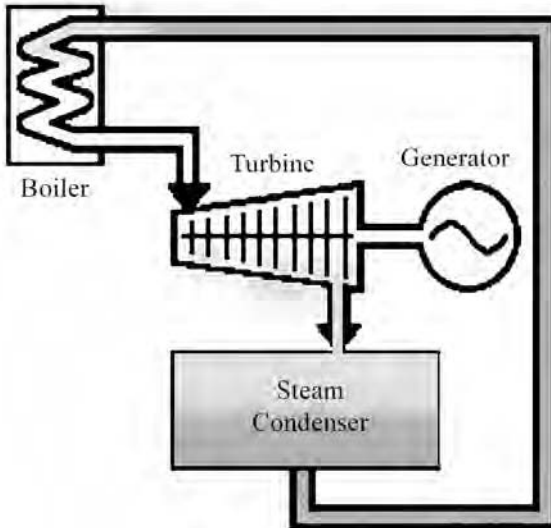

Figure 2-16. Reflective solar power plant and schematic. *Source:* Fotosearch.

definition a *black start* unit. Black start means that electrical power is not needed first in order to start a hydro power plant. Hydro plants have a relatively long life; 50–60 year life spans are common. Some hydroelectric power plants along the Truckee River in California have been in operation for over 100 years. Figure 2-17 shows a typical hydroelectric power plant.

The cross-section of a typical low-head hydro installation is shown in

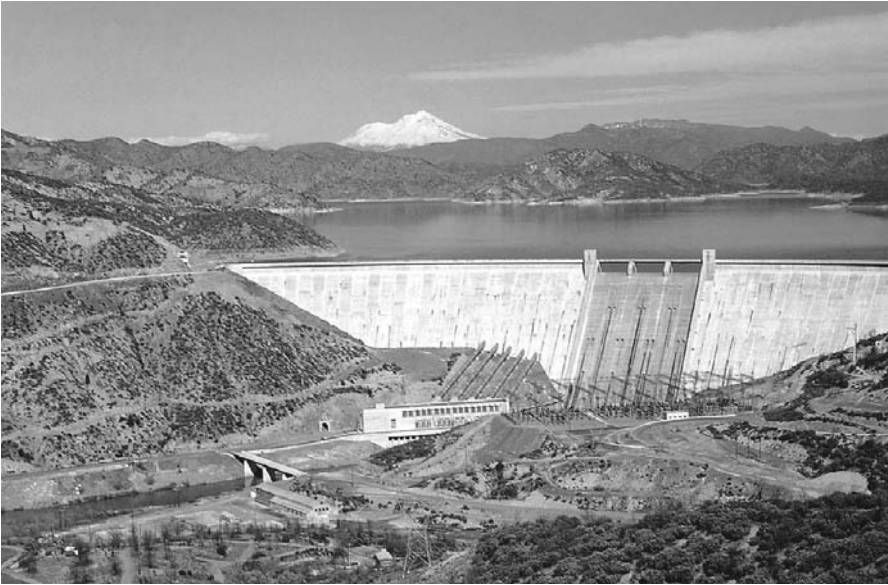

Figure 2-17. Hydroelectric power plant. *Source:* Photovault.

Figure 2-18. Basically, the water behind the dam is transported to the turbine by means of a *penstock*. The turbine causes the generator to rotate, producing electricity, which is then delivered to the load center over long-distance power lines. The water coming out of the turbine goes into the river.

## Pumped Storage Hydro Power Plants

Pumped storage hydro power production is a means of actually saving electricity for future use. Power is generated from water falling from a higher lake to a lower lake during peak load periods. The operation is reversed during off-peak conditions by pumping the water from the lower lake back to the upper lake. A power company can obtain high-value power during peak-load generation periods by paying the lower cost to pump the water back during off-peak periods. Basically, the machine at the lower level is reversible; hence, it operates as a hydro-generator unit or a motor-pump unit.

One of the problems associated with pumped storage units is the process of getting the pumping motor started. Starting the pumping motor using the system's power line would usually put a low-voltage sag condition on the pow-

er system. The voltage sag or dip could actually cause power quality problems. In some cases, two turbines are used in a pumped storage installation. One of the turbines is used as a generator to start the other turbine that is used as a pump. Once the turbine is turning, the impact on the power system is much less, and the second turbine can then be started as a motor-pump.

Figure 2-19 shows a cross-sectional view of the Tennessee Valley Authority's pumped storage plant at Raccoon Mountain. The main access tunnel was originally used to bring all of the equipment into the powerhouse: the turbine, the pumps, and the auxiliary equipment. Note that the Tennessee Valley Authority installed a visitor center at the top of the mountain so that the installation could be viewed by the general public.

## Combustion Turbine Generation Plants

Combustion turbine (CT) power plants burn fuel in a jet engine and use the exhaust gasses to spin a turbine generator. The air is compressed to a very high pressure. Fuel is then injected into the compressed air and ignited, producing high-pressure and high-temperature exhaust gasses. The exhaust is moved through turbine blades much the same way steam is moved through turbine blades in a steam power plant. The exhaust gas movement through the combustion turbine results in the rotation of the generator rotor, thus producing electricity. The exhaust from the CT remains at a very high temperature and pressure after leaving the turbine. Figure 2-20 shows a combustion turbine generator.

One of the advantages of combustion turbines is that they can actually be designed to be remotely controlled for unmanned sites. They offer fast start-up times and fast installation times. In some cases, the purchase of the combustion turbine generator system can be "turnkey," that is, the owner simply contracts for a complete installation and takes over when the plant is finished and ready to operate. In most cases, the combustion turbine generator package is a completely self-contained unit. In fact, some of the smaller-capacity systems are actually built on trailers so that they can be moved quickly to sites requiring emergency generation.

Combustion turbines can be extremely responsive to power system changes. They can go from no load to full load and vice versa in a matter of seconds or in a matter of minutes.

The disadvantages are limited fuel options (i.e., diesel fuel, jet fuel, or natural gas) and inefficient use of exhaust heat.

There are several environmental issues related to the use of combustion turbines. Without appropriate treatment, the exhaust emissions can be very high in undesirable gases. The high temperatures in the combustion cham-

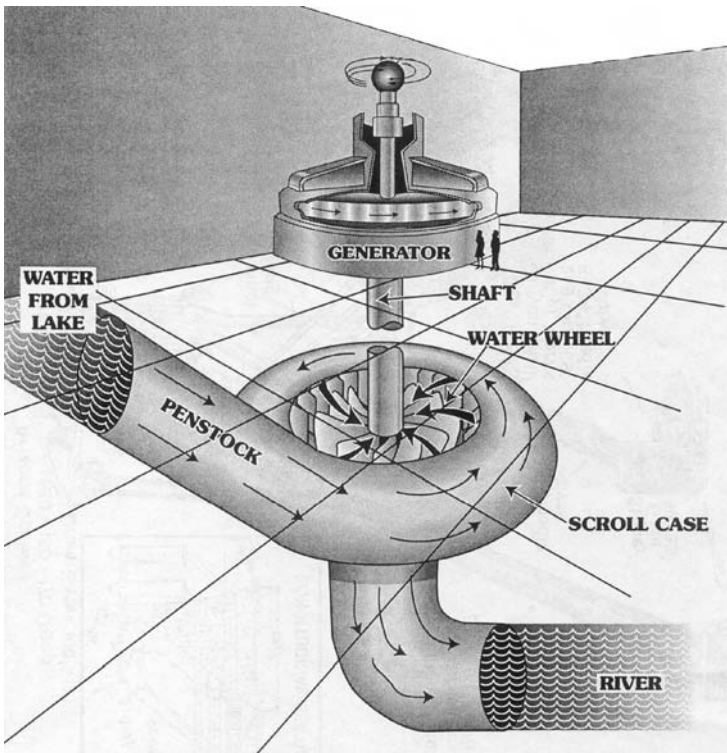
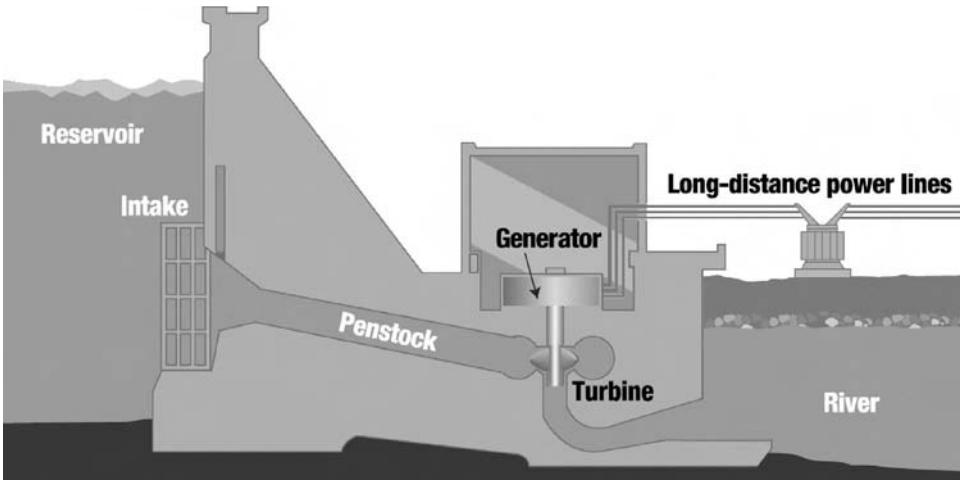

Figure 2-18. Hydroelectric power plant.





Figure 2-18. *Continued*

ber will increase the production of nitric oxide gases and their emissions. Depending on the fuel used, there can be particulate emissions problems. That is, particles or other materials tend to increase the opacity (i.e., smoke) of the gases. Sound levels around combustion turbine installations can be very high. Special sound reduction systems are available and used. (Note: combustion turbines are typically jet engines, very similar to those heard at airports.)

The heat rate or efficiency of a simple-cycle combustion turbine is not very good. The efficiencies are somewhere in the range of 20 to 40% maximum.

One effective way to overcome some of the cost is to incorporate a heat



Figure 2-19. Pumped storage power plant.



Figure 2-20. Combustion turbine power plant.

exchanger so the exhaust gases can be used to generate steam that will drive a secondary steam turbine. Many CTs are used as combined-cycle power plants.

### **Combined-Cycle Power Plants (Combustion and Steam)**

The combined-cycle power plant consists of two means of generation: combustion turbine and steam turbine. The combustion turbine is similar to a jet engine whose high-temperature and high-pressure exhaust spins a turbine whose shaft is connected to a generator. The hot exhaust is then coupled through a *heat recovery steam generator* (HRSG) that is used to heat water, thus producing steam to drive a secondary steam turbine generator. The combustion turbine typically uses natural gas as the fuel to drive the turbine blades.

The advantage of a combined-cycle (CC) system is that in addition to the electrical energy produced by the fuel combustion engine, the exhaust from the engine also produces electrical energy. Another potential benefit of CC plants is that the end user can have steam made available to assist in other functions such as building heat and hot water and production processes that require steam (such as paper mills). Therefore, from one source of fuel (i.e., natural gas), many energy services are provided (electrical energy, steam, hot water, and building heat). Some CCs can reach efficiencies near 90%. Figure 2-21 shows a combined-cycle power plant.

### **Wind Turbine Generators**

Wind generation has increased in popularity and the technology has improved tremendously over the last decade. In the year 2006, the total installed capacity of U.S. wind generation was about 11,000 MW. Wind turbine generators are continuing to be installed worldwide. The total installed capacity worldwide is about 74,000 MW. Figure 2-22 shows typical wind generators.

Wind turbine generators tend to have a high cost per kWh produced. There is also a concern about the availability of wind on a constant basis. Most power companies do not consider wind generators to be *base load* units. Base load implies that units are readily available and that they are part of a 24 hour generation production schedule. They are brought online when available.

Basically, the concept of wind power is that the wind energy is converted into electrical energy by means of modern windmills. One interesting characteristic of wind power is the fact that power produced is proportional to

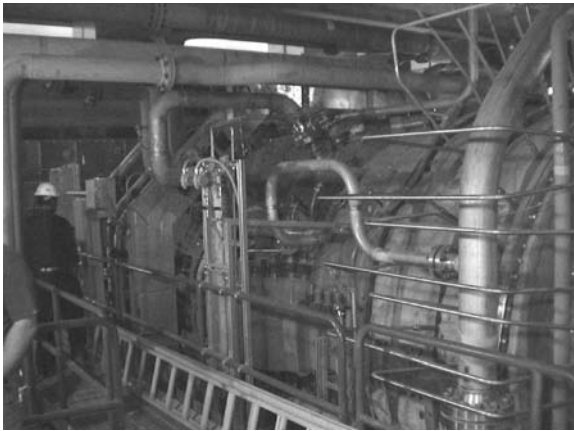
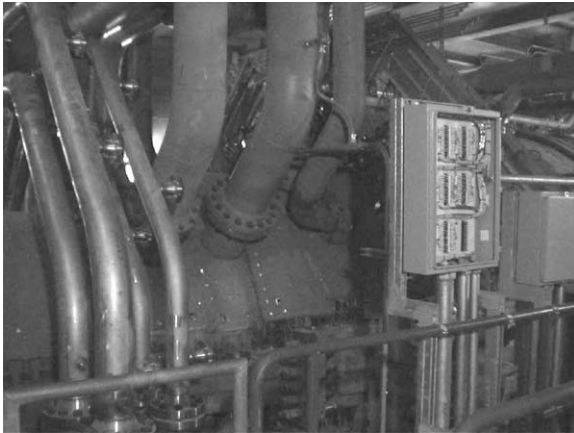

Figure 2-21. Combined-cycle power plant.



Figure 2-22. Wind power. *Source:* Fotosearch.

the cube of the wind speed. In other words, if the wind speed is doubled, the power produced is tripled or increased by a factor of eight. Thus, what might appear to humans as modest changes in breezes severely impact wind power production.

Installation of wind power generators requires selecting sites that are relatively unrestricted to wind flow, preferably at high elevations, and within close proximity to suitable powerlines. Obviously, the site selected should have a fairly constant wind speed.

Wind power is accepted as free energy with no fuel costs. Wind power is also considered renewable energy, since wind really never goes away.

### **Solar Direct Generation (Photovoltaic)**

The *photovoltaic* (sometimes called “voltaic” for short) type of solar power plant converts the sun’s energy directly into electrical energy. A photovoltaic array is shown in Figure 2-23. This type of production uses various types of films or special materials that convert sunlight into direct current (dc) electrical energy systems. Panels are then connected in series and parallel to obtain the desired output voltage and current ratings. Some systems use an



Figure 2-23. Direct Solar Photovoltaic. *Source:* Fotosearch.

energy storage device (i.e., battery) to provide electrical power during off-sun-peak periods. This dc energy is converted to utility ac energy by means of a device called an *inverter*.

Larger-scale voltaic solar power systems are typically made of 1.5 Vdc solar cells capable of producing approximately 20 ma of electrical current each. A typical solar photovoltaic panel measuring 4 feet by 1 foot would produce approximately 50–60 watts of electrical power. Therefore, a 4 foot panel would supply power for a 60 watt lightbulb during daylight hours. Given today's technology and the space that is needed, direct solar voltaic systems are not practical for large-scale electric power production.

Solar plants are environmentally friendly as they produce no pollution. The main drawback to these plants is the cost of the panels and conversion equipment. Technology has produced more efficient panels at lower cost, and direct solar systems will eventually be more cost-effective. They are currently used commercially to power small devices in remote areas. There remain several tax incentives to promote use of solar power by residential and small business consumers.

---

# TRANSMISSION LINES

---

## CHAPTER OBJECTIVES

- ✓ *Explain why high-voltage transmission lines are used*
- ✓ *Explain the different conductor types, sizes, materials, and configurations*
- ✓ *Discuss the different types of insulation used for overhead and underground conductors*
- ✓ *Identify the common electric power system transmission voltage classes*
- ✓ *Discuss the different transmission line electrical design characteristics (insulation, air gaps, lightning performance, etc.)*
- ✓ *Explain the differences between ac and dc transmission line design, reliability, applications, and benefits*
- ✓ *Discuss overhead and underground transmission systems*

## TRANSMISSION LINES

Why use high-voltage transmission lines? The best answer to that question is that high-voltage transmission lines transport power over long distances

much more efficiently than lower-voltage distribution lines for two main reasons. First, high-voltage transmission lines take advantage of the power equation, that is, power is equal to the voltage times current. Therefore, increasing the voltage allows one to decrease the current for the same amount of power. Second, since transport losses are a function of the square of the current flowing in the conductors, increasing the voltage to lower the current drastically reduces transportation losses. Plus, reducing the current allows one to use smaller conductor sizes.

Figure 3-1 shows a three-phase 500 kV transmission line with two conductors per phase. The two-conductors-per-phase option is called *bundling*. Power companies bundle multiple conductors—double, triple, or more—to increase the power transport capability of a power line. The type of insulation used in this line is referred to as *V-string* insulation. V-string insulation, compared to *I-string* insulation, provides stability in wind conditions. This line also has two *static wires* on the very top to shield itself from lightning. The static wires in this case do not have insulators; instead, they are directly connected to the metal towers so that lightning strikes are immediately grounded to earth. Hopefully, this shielding will keep the main power conductors from experiencing a direct lightning strike.

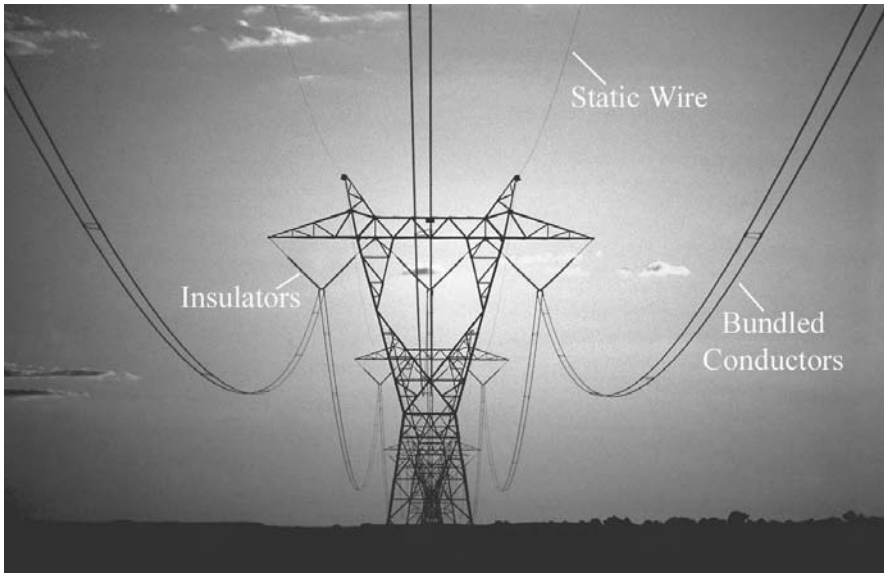

Figure 3-1. High-voltage transmission line. Source: Photovault.



## Raising Voltage to Reduce Current

Raising the voltage to reduce current reduces conductor size and increases insulation requirements. Let us look at the power equation again:

$$\text{Power} = \text{Voltage} \times \text{Current}$$

$$\text{Voltage}_{\text{In}} \times \text{Current}_{\text{In}} = \text{Voltage}_{\text{Out}} \times \text{Current}_{\text{Out}}$$

From the power equation above, raising the voltage means that the current can be reduced for the same amount of power. The purpose of step-up transformers at power plants, for example, is to increase the voltage to lower the current for power transport over long distances. Then at the receiving end of the transmission line, step-down transformers are used to reduce the voltage for easier distribution.

For example, the amount of current needed to transport 100 MW of power at 230 kV is half the amount of current needed to transport 100 MW of power at 115 kV. In other words, doubling the voltage cuts the required current in half.

The higher-voltage transmission lines require larger structures with longer insulator strings in order to have greater air gaps and needed insulation. However, it is usually much cheaper to build larger structures and wider right of ways for high-voltage transmission lines than it is to pay the continuous cost of high losses associated with lower-voltage power lines. Also, to transport a given amount of power from point “a” to point “b,” a higher-voltage line can require much less right of way land than multiple lower-voltage lines that are side by side.

## Raising Voltage to Reduce Losses

The cost due to losses decreases dramatically when the current is lowered. The power losses in conductors are calculated by the formula  $I^2R$ . If the current ( $I$ ) is doubled, the power losses quadruple for the same amount of conductor resistance ( $R$ )! Again, it is much more cost effective to transport large quantities of electrical power over long distances using high-voltage transmission lines because the current is less and the losses are much less.

## Bundled Conductors

Bundling conductors significantly increases the power transfer capability of the line. The extra relatively small cost when building a transmission line to

add bundled conductors is easily justified since bundling the conductors actually doubles, triples, quadruples, and so on the power transfer capability of the line. For example, assume that a right of way for a particular new transmission line has been secured. Designing transmission lines to have multiple conductors per phase significantly increases the power transport capability of that line for a minimal extra overall cost.

## CONDUCTORS

Conductor material (all wires), type, size, and current rating are key factors in determining the power handling capability of transmission lines, distribution lines, transformers, service wires, and so on. A conductor heats up when current flows through it due to its resistance. The resistance per mile is constant for a conductor. The larger the diameter of the conductor, the less resistance there is to current flow.

Conductors are rated by how much current causes them to heat up to a predetermined amount of degrees above ambient temperature. The amount of temperature rise above ambient (i.e., when no current flows) determines the current rating of a conductor. For example, when a conductor reaches 70°C above ambient, the conductor is said to be at full load rating. The power company selects the temperature rise above ambient to determine acceptable conductor ratings. The power company might adopt a different current rating (i.e., temperature rating) for emergency conditions.

The amount of current that causes the temperature to rise depends on the conductor material and size. The conductor type determines its strength and application in electric power systems.

### Conductor Material

Utility companies use different conductor materials for different applications. Copper, aluminum, and steel are the primary types of conductor materials used in electrical power systems. Other types of conductors, such as silver and gold, are actually better conductors of electricity; however, cost prohibits wide use of these materials.

#### *Copper*

Copper is an excellent conductor and is very popular. Copper is very durable and is not affected significantly by weather.

## **Aluminum**

Aluminum is a good conductor but not as good or as durable as copper. However, aluminum costs less. Aluminum is rust resistant and weighs much less than copper.

## **Steel**

Steel is a poor conductor when compared to copper and aluminum; however, it is very strong. Steel strands are often used as the core in aluminum conductors to increase the tensile strength of the conductor.

## **Conductor Types**

Power line conductors are either solid or stranded. Rigid conductors such as hollow aluminum tubes are used as conductors in substations because of the added strength against sag in low-profile substations when the conductor is only supported at both ends. Rigid copper bus bars are commonly used in low-voltage switch gear because of their high current rating and relatively short lengths.

The most common power line conductor types are shown below:

**Solid.** *Solid* conductors (Figure 3-2) are typically smaller and stronger than stranded conductors. Solid conductors are usually more difficult to bend and are easily damaged.

**Stranded.** As shown in Figure 3-3, *stranded* conductors have three or more strands of conductor material twisted together to form a single conductor. Stranded conductors can carry high currents and are usually more flexible than solid conductors.

**Aluminum Conductor, Steel-Reinforced (ACSR).** To add strength to aluminum conductors, Figure 3-4 shows steel strands that are used as the core of aluminum stranded conductors. These high-strength conductors are normally used on long span distances, for minimum sag applications.

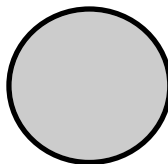

Figure 3-2. Solid conductor.

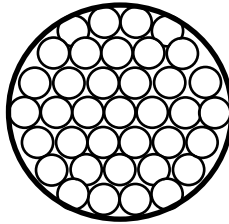

Figure 3-3. Stranded conductor.

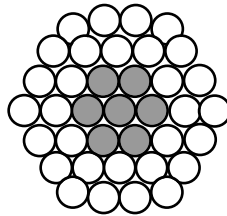

Figure 3-4. ACSR conductor.

### Conductor Size

There are two conductor size standards used in electrical systems. One is for smaller conductor sizes (American Wire Gauge) and the other is for larger conductor sizes (circular mils). Table 3-1 compares conductor sizes and standards.

#### ***American Standard Wire Gauge (AWG)***

The American Standard Wire Gauge is an old standard that is used for relatively small conductor sizes. The scale is in reverse order; in other words, the numbers get smaller as the conductors get larger. The circular mils standard of measurement is used for large conductor sizes.

#### ***Circular Mils***

Conductors greater than AWG 4/0 are measured in circular mils (cmils). One circular mil is equal to the area of a circle having a 0.001 inch (1 mil) diameter. For example, the magnified conductor in the Figure 3-5 has 55 circular mils. In actual size, a conductor of 55 circular mils is about four times smaller than the period at the end of this sentence. Therefore, conductors sized in circular mils are usually stated in thousands of circular mils (i.e., kcm).

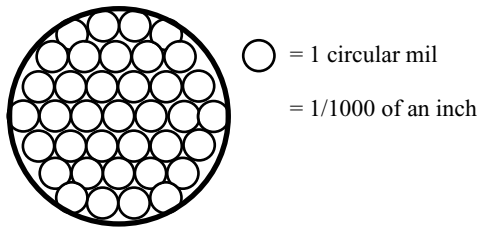

Figure 3-5. Circular mils.

Table 3-1 shows typical conductor sizes and associated current ratings for outdoor bare ACSR conductors having a current rating of 75°C rise above ambient. The table also shows the equivalent copper size conductor.

### Insulation and Outer Covers

Metal wire current-carrying conductors can be insulated or noninsulated when in use. Noninsulated conductors (i.e., bare wires) normally use what are called “insulators” as the means for separating the bare wires from the grounded structures, making air their insulation. Insulated conductors use plastic, rubber, or other jacketing materials for electrical isolation. High-voltage insulat-

Table 3-1. Typical ACSR conductor sizes

Cross section (inches)	Size, (AWG or cmils)	Size, copper equivalent	Ratio (Al to steel)	Diameter (inches)	Current (amps), (75°C rise)
0.250	4	6	7/1	0.250	140
0.325	2	4	6/1	0.316	180
0.398	1/0	2	6/1	0.398	230
0.447	2/0	1	6/1	0.447	270
0.502	3/0	1/0	6/1	0.502	300
0.563	4/0	2/0	6/1	0.563	340
0.642	266,000	3/0	18/1	0.609	460
0.783	397,000	250,000	26/7	0.783	590
1.092	795,000	500,000	26/7	1.093	900
1.345	1,272,000	800,000	54/19	1.382	1,200

ed conductors are normally used in underground systems. Insulated low-voltage service wires are often used for residential overhead and underground lines.

In the 1800s, Ronalds, Cooke, Wheatstone, Morse, and Edison made the first insulated cables. The insulation materials available at that time were natural substances such as cotton, jute, burlap, wood, and oil-impregnated paper. With the development of rubber compounds and the invention of plastic, insulation for underground cables have become much more reliable and efficient.

### Voltage Classes

Table 3-2 shows the various transmission and subtransmission system voltages used in North America. This table is not absolute; some power companies designate their system voltages a little differently. Note: it is quite common to use subtransmission voltages to transport power over medium distances (i.e., across large populated areas) or to transport power over long distances if the total current requirement is low, such as for serving less populated areas that are far away.

The higher transmission system voltages tend to be more standardized compared to the lower distribution voltages. There are many more subtle variations in distribution voltages than transmission voltages.

*Voltage class* is the term often used by equipment manufacturers and power companies to identify the voltage that the equipment will be connected to. A manufacturer might use the voltage class to identify the intended system operating voltage for their equipment. A power company might use the voltage class as a reference to the system discussed in a conversation. A

Table 3-2. Transmission voltages

Voltage class	Voltage category	System voltage
69,000		Subtransmission
115,000		
138,000		
161,000		Transmission
230,000	Extra high voltage (EHV)	
345,000		
500,000		
765,000		
Above 1,000,000	Ultra high voltage (UHV)	

voltage class might include several *nominal* operating voltages. Nominal voltages are the everyday normal, actual voltages. For example, a circuit breaker might be a 125 kV voltage class piece of equipment that is operating at a nominal 115 kV voltage.

*Voltage category* is often used to identify a group of voltage classes. For example, “extra high voltage” (or EHV) is a term used to state whether an equipment manufacturer builds transmission equipment or distribution equipment, which would be categorized as “high-voltage equipment” (or HV).

*System voltage* is a term used to identify whether distribution, transmission, or secondary is referenced. For example, power companies normally distinguish between distribution and transmission departments. A typical power company might distinguish between distribution line crews, transmission line crews, and so on. Secondary system voltage usually refers to customer service voltages.

## **TRANSMISSION LINE DESIGN PARAMETERS (OPTIONAL SUPPLEMENTARY READING)**

This section discusses in more detail the design parameters for high-voltage transmission lines.

### **Insulation**

The minimum insulation requirements for a transmission line are determined by first evaluating individually the minimum requirements for each of the following factors.

Any of the insulation criteria listed below could dictate the minimum spacing and insulation requirements for the transmission line.

#### ***Air Gaps for 60 Hertz Power Frequency Voltage***

Open air has a flashover voltage rating. A rule of thumb is one foot of air gap for every 100 kV of voltage. Detailed reference charts are available to determine the proper air gap requirements based on operating voltage, elevation, and exposure conditions.

#### ***Contamination Levels***

Transmission lines located near oceans, alkali salt flats, cement factories, and so on require extra insulation for lines to perform properly in contami-

nation prone environments. Salt mixed with moisture, for example, can cause leakage currents and possible undesirable insulation flashovers to occur. Extra insulation is often required for these contamination prone environments. This extra insulation could increase the minimum air gap clearance.

### ***Expected Switching Surge Overvoltage Conditions***

When power system circuit breakers operate, or large motors start, or disturbances happen on the power grid, transient voltages could occur that can flashover the insulation or air gap. The design engineer studies all possible switching transient conditions to make sure adequate insulation is provided on the line at all times.

### ***Safe Working Space***

The National Electrical Safety Code (NESC) specifies the minimum phase-to-ground and phase-to-phase air-gap clearances for all power lines and substation equipment. These NESC clearances are based on safe working space requirements. In some cases, the minimum electrical air-gap clearance is increased to meet NESC requirements.

### ***Lightning Performance***

Transmission lines frequently use shield wires to improve the line's operating performance under lightning conditions. These *shield wires* (sometimes called *static wires* or *earth wires*) serve as a high-elevation ground wires to attract lightning. When lightning strikes the shield wire, surge current flows through the wires, through the towers, through ground rods, and into the earth, where the energy is dissipated. Sometimes extra air-gap clearance is needed in towers to overcome the possibility of the tower flashing back over to the power conductors when lightning energy is being dissipated. This condition is mitigated by good tower grounding practices.

### ***Audible Noise***

Audible noise can also play a role in designing high-voltage power lines. Audible noise can be the result of foul weather, electrical stress, or corona discharge, and the low-frequency hum can become troublesome if not



evaluated during the design process. There are ways to minimize audio noise, most of which tend to increase conductor size and/or air-gap spacing.

## **UNDERGROUND TRANSMISSION (OPTIONAL SUPPLEMENTARY READING)**

Underground transmission is usually three to ten times more costly than overhead transmission due to right of way requirements, obstacles, and material costs. It is normally used in urban areas or near airports where overhead transmission is not an option. Cables are made of solid dielectric polyethylene materials and can have ratings on the order of 400 kV. Figure 3-6 shows a 230 kV underground transmission line.

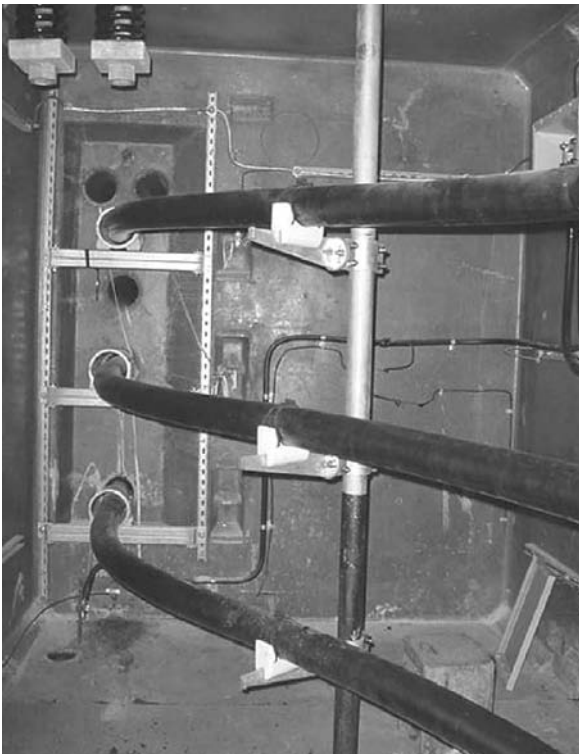

Figure 3-6. Underground transmission line.

## dc TRANSMISSION SYSTEMS (OPTIONAL SUPPLEMENTARY READING)

dc Transmission systems are sometimes used for economic reasons, system synchronization benefits, and power flow control. The three-phase ac transmission line is converted into a two-pole (plus and minus) dc transmission line using bidirectional rectification *converter stations* at both ends of the dc line. The converter stations convert the ac power into dc power and vice versa. The reconstructed ac power must be filtered for improved power quality performance before being connected to the ac system.



Figure 3-7. Overhead dc transmission line.

dc transmission lines do not have phases; instead, they have positive and negative *poles*. The Pacific Northwest dc transmission line shown in Figure 3-7 for example operates at  $\pm 500$  kV or 1 million volts pole to pole. There are no synchronization issues with dc lines. The frequency of dc transmission is zero and, therefore, there are no concerns about variations in frequency between interconnected systems. A 60 hertz system can be connected to a 50 hertz system using a dc line.

For economic reasons, the dc line may have advantages over the ac line in that the dc lines have only two conductors versus three conductors in ac lines. The overall cost to build and operate a dc line, including converter stations, may cost less than an equivalent ac line due to the savings from one less conductor, narrower right of ways, and less expensive towers.



---

# SUBSTATIONS

---

## CHAPTER OBJECTIVES

- ✓ *Identify all major equipment used in substations*
- ✓ *Describe the purpose and operation of each major equipment type*
- ✓ *Discuss the different types of transformers*
- ✓ *Explain the operation of voltage regulators and tap changers*
- ✓ *Understand the advantages and disadvantages of oil and gas equipment*
- ✓ *Discuss the different types of circuit breakers and how they are used*
- ✓ *Explain the purpose of capacitors, reactors, and static VAR compensators used in electric power systems*
- ✓ *Discuss the equipment found in control buildings*
- ✓ *Discuss the effective preventative maintenance programs used for substation equipment*

## SUBSTATION EQUIPMENT

The major types of equipment found in most transmission and distribution substations are discussed in this chapter. The purpose, function, design

characteristics, and key properties are all explained. After the equipment is discussed, planned and essential predictive maintenance techniques are discussed. The reader should get a good fundamental understanding of all the important aspects of the major equipment found in substations and how they are used and operated.

The substation equipment discussed in this chapter includes:

- Transformers
- Regulators
- Circuit breakers and reclosers
- Air disconnect switches
- Lightning arresters
- Electrical buses
- Capacitor banks
- Reactors
- Static VAR compensators
- Control building
- Preventative maintenance

## TRANSFORMERS

Transformers are essential components in electric power systems. They come in all shapes and sizes. Power transformers are used to convert high-voltage power to low-voltage power and vice versa. Power can flow in both directions: from the high-voltage side to the low-voltage side or from the low-voltage side to the high-voltage side. Generation plants use large *step-up* transformers to raise the voltage of the generated power for efficient transport of power over long distances. Then *step-down* transformers convert the power to subtransmission, as in Figure 4-1, or distribution voltages, as in Figure 4-2, for further transport or consumption. *Distribution transformers* are used on distribution lines to further convert distribution voltages down to voltages suitable for residential, commercial, and industrial consumption (see Figure 4-3).

There are many types of transformers used in electric power systems. *Instrument transformers* are used to connect high-power equipment to low-power electronic instruments for monitoring system voltages and currents at convenient levels. Instrument transformers include *CTs* and *PTs* (i.e., current transformers and potential transformers). These instrument transform-



Figure 4-1. Step-down transformer.

ers connect to metering equipment, protective relaying equipment, and telecommunications equipment. *Regulating transformers* are used to maintain proper distribution voltages so that consumers have stable wall outlet voltage. *Phase shifting* transformers are used to control power flow between tie lines.

Transformers can be single phase, three phase, or *banked* together to operate as a single unit. Figure 4-3 shows a three phase transformer bank.

## Transformer Fundamentals

Transformers work by combining the two physical laws that were discussed earlier in Chapter 2. Physical law #1 states that a voltage is produced on any conductor in a changing magnetic field. Physical law #2 states that a current flowing in a wire produces a magnetic field. Transformers combine these



Figure 4-2. Distribution power transformer.

principles by using two coils of wire and a changing voltage source. The current flowing in the coil on one side of the transformer induces a voltage in the coil on the other side. (Hence, the two coils are coupled by the magnetic field.)

This is a very important concept because the entire electric power system depends on these relationships. Looking at them closely; the voltage on the opposite side of a transformer is proportional to the turns ratio of the transformer, and the current on the other side of the transformer is inversely proportional to the turns ratio of the transformer. For example, the transformer in Figure 4-4 has a turns ratio of 2:1.





Figure 4-3. Transformer bank.

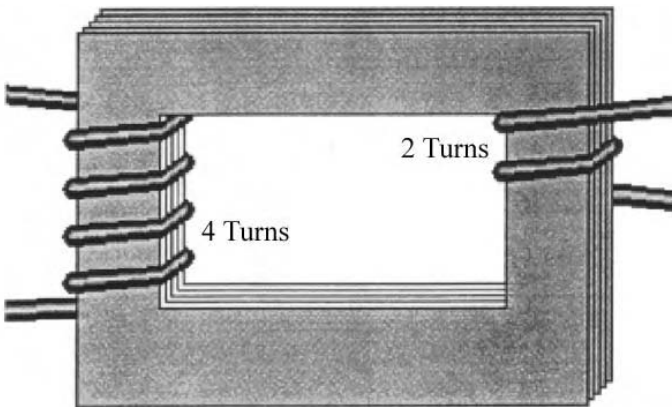

Figure 4-4. Transformer windings. Courtesy of Alliant Energy.

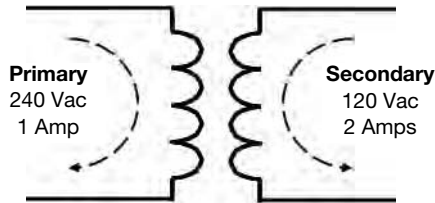

Figure 4-5. Transformer turn ratio.

If the 2:1 turns ratio transformer in Figure 4-4 has 240 Vac at 1 amp applied on its primary winding (left side), it will produce 120 Vac at 2 amps on its secondary winding (right side), as seen in Figure 4-5. Note: power equals 240 watts on either side (i.e., voltage  $\times$  current). As discussed earlier, raising the voltage (i.e., like on transmission lines) lowers the current and thus significantly lowers system losses.

## Power Transformers

Figure 4-6 shows the inside of a large power transformer. Power transformers consist of two or more windings for each phase and these windings are usually wound around an *iron core*. The iron core improves the efficiency of the transformer by concentrating the magnetic field and reduces transformer losses. The high-voltage and low-voltage windings have a unique number of coil turns. The turns ratio between the coils dictates the voltage and current relationships between the high- and low-voltage sides.

## Bushings

Bushings are used on transformers, circuit breakers, and many other types of electric power equipment as connection points. Bushings connect outside conductors to conductors inside equipment. Bushings provide insulation between the energized conductor and the grounded metal tank surrounding the conductor. The conductors inside the bushings are normally solid copper rods surrounded by porcelain insulation. Usually an insulation dielectric such as oil or gas is added inside the bushing between the copper conductor and the porcelain housing to improve its insulation properties. Mineral oil and sulfur hexafluoride ( $\text{SF}_6$ ) gas are common dielectric materials used to increase insulation.

Note: transformers have large bushings on the high-voltage side of the unit and small bushings on the low-voltage side. In comparison, circuit breakers (discussed later) have the same size bushings on both sides of the unit.

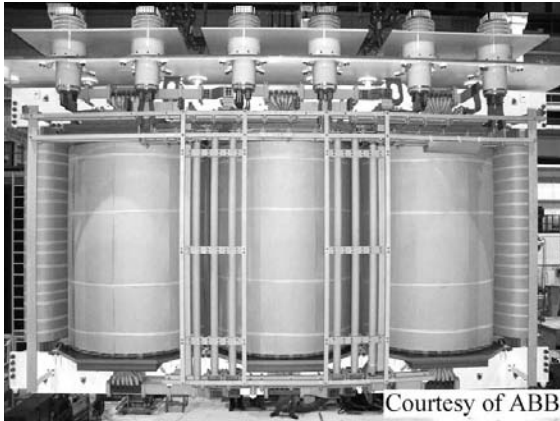

Figure 4-6. Transformer core and coils.

Figures 4-7 and 4-8 are examples of typical transformer bushings. Notice the oil level visible through the glass portion at the top of the bushing. Sometimes, oil level gauges are used for oil level inspections.

The part of the bushing that is exposed to the outside atmosphere generally has *skirts* to reduce unwanted leakage currents. The purpose of the skirts is to increase the leakage current distance in order to decrease the leakage current.



Figure 4-7. Bushing oil level gauge.

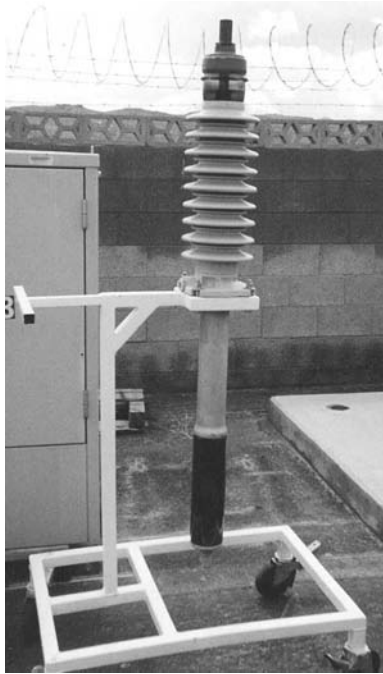

Figure 4-8. Transformer bushing.

Cleanliness of the outside porcelain is also important. Contaminated or dirty bushings can cause arcing that can result in flashovers, especially during light rain or fog conditions.

## Instrument Transformers

The term *instrument transformer* refers to current and voltage transformers that are used to scale down actual power system quantities for metering, protective relaying, and/or system monitoring equipment. The application of both current and potential transformers also provides scaled-down quantities for power and energy information.

### Current Transformers

*Current transformers* or *CTs* are used to scale down the high magnitude of current flowing in high-voltage conductors to a level much easier to work with safely. For example, it is much easier to work with 5 amperes of current in the CT's secondary circuit than it is to work with 1,000 amperes of current in the CT's primary circuit.

Figure 4-9 shows a typical CT connection diagram. Using the CT's turn ratio as a *scale factor* provides the current level required for the monitoring instrument. Yet, the current located in the high-voltage conductors is actually being measured.

*Taps* (or connection points to the coil) are used to allow options for various turns ratio scale factors to best match the operating current to the instrument's current requirements.

Most CTs are located on transformer and circuit breaker bushings, as shown in Figure 4-10. Figure 4-11 shows a stand-alone high-voltage CT.

### Potential Transformers

Similarly, *potential transformers (PTs)* are used to scale down very high voltages to levels that are safer to work with. For example, it is much easier to work with 115 Vac than 69 kVac. Figure 4-12 shows how a PT is connected. The 600:1 scale factor is taken into account in the calculations of actual voltage. PTs are also used for metering, protective relaying, and system monitoring equipment. The instruments connected to the secondary side of the PT are programmed to account for the turns ratio scale factor.

Like most transformers, taps are used to allow options for various turns ratios to best match the operating voltage with the instrument's voltage-level-

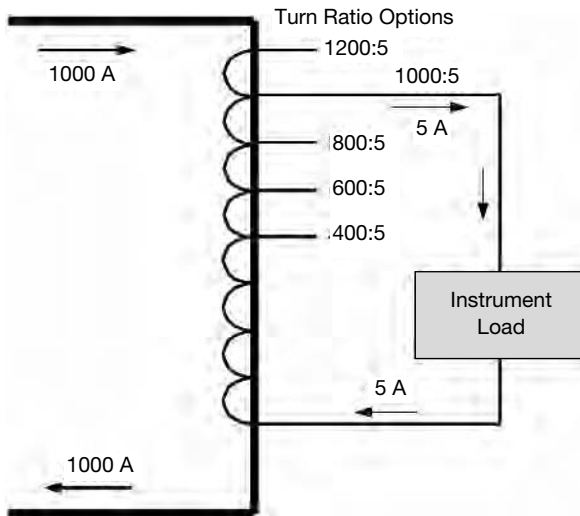

Figure 4-9. CT connections.



Figure 4-10. Bushing CT.

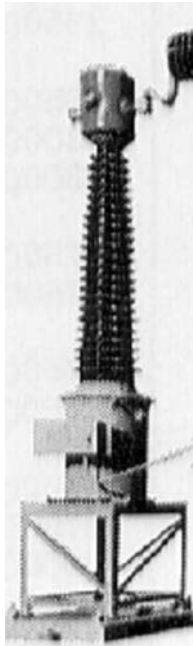

Figure 4-11. External high-voltage CT.

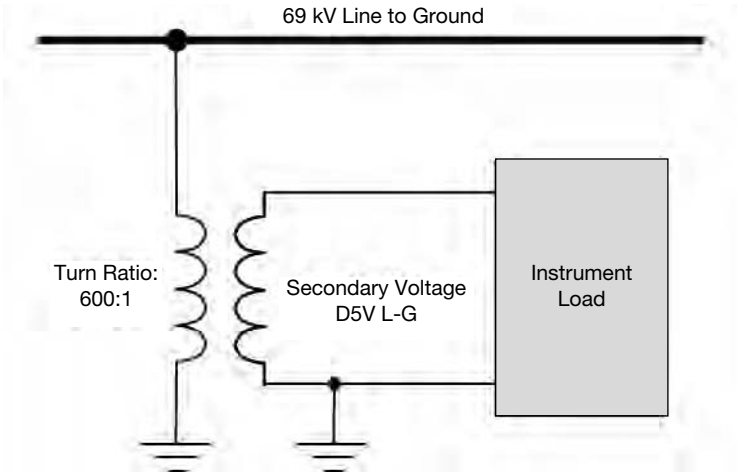

Figure 4-12. PT Connections.

el requirements. An example of a low-voltage PT is shown in Figure 4-13 and a high-voltage PT in Figure 4-14.



Figure 4-13. Low-voltage PT. Courtesy Alliant Energy.



Figure 4-14. High-voltage PT. Courtesy Alliant Energy.

### **Autotransformers (Optional Supplementary Reading)**

*Autotransformers* are a specially constructed variations of regular two-winding transformers. Autotransformers share a winding. Single-phase, two-winding autotransformers contain a primary winding and a secondary winding on a common core. However, part of the high-voltage winding is shared with the low-voltage winding on an autotransformer.

Autotransformers work best with small turns ratios (i.e., less than 5:1). Autotransformers are normally used for very high voltage transmission applications. For example, autotransformers are commonly found matching 500 kV to 230 kV or 345 kV to 120 kV system voltages. Material cost savings is an advantage of autotransformers. Size reduction is another advantage of autotransformers.

Figure 4-15 shows how an autotransformer is connected. The physical appearance looks the same as any other power transformer. A person needs



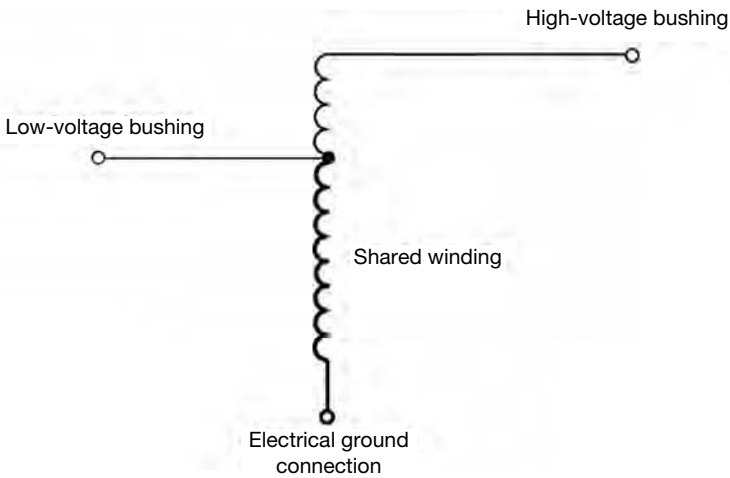

Figure 4-15. Autotransformer.

to view the transformer nameplate to tell whether it is an autotransformer or a conventional transformer.

Note: under no-load conditions, the high-side voltage will be the sum of the primary and shared winding voltages, and the low-side voltage will be equal to the shared winding voltage.

## REGULATORS

It is important for electric utility companies to provide their customers with regulated or steady voltage all the time, otherwise several undesirable conditions might occur. Normally, residential 120 Vac is *regulated* to  $\pm 5\%$  (i.e., 126 Vac  $\leftrightarrow$  114 Vac). The first residential customer outside the substation should not have voltage exceeding 126 Vac and the last customer at the end of the distribution feeder should not have voltage less than 114 Vac. Power companies try to regulate the distribution voltage to be within a nominal 124 Vac to 116 Vac.

Customer service problems can occur if voltages are too high or too low. For example, low voltage can cause motors to overheat and burn out. High voltages can cause lightbulbs to burn out too often or cause other appliance issues. Utility companies use voltage regulators to keep the voltage level within an acceptable or controlled range or bandwidth.

Voltage regulators are similar to transformers. Regulators have several taps on their windings that are changed automatically under load conditions

by a motor-driven control system called the *load tap changer* or *LTC*. Figure 4-16 shows a substation three-phase voltage regulator and Figure 4-17 shows a single-phase regulator. Three single-phase regulators can be used in a substation or out on a distribution line.

### Theory of Operation

Normally, a regulator is specified as being (10%. The distribution voltage out of the substation regulator can be raised 10% or lowered 10%. There are 16 different tap positions on either the raising or lowering sides of the neutral position. There is a reversing switch inside the LTC that controls whether to use the plus voltage or minus voltage direction. Therefore, the typical voltage regulator has “33 positions” (i.e., 16 raise, 16 lower, plus neutral). Figure 4-18 shows the 33 positions on the dial. Each position can change the primary distribution voltage by 5/8% (i.e., 10% divided by 16 taps).

For example, a typical of 7200 volt, ( $\pm 10\%$  distribution regulator would have 33 tap positions. Each tap could raise or lower the primary distribution voltage 45 volts (i.e., 10% of 7200 equals 720 volts, and 720 volts divided by 16 taps equals 45 volts per tap).

*Reactor coils* are used to reduce the number of actual winding taps to eight instead of 16. Reactor coils allow the regulator’s output contactor to

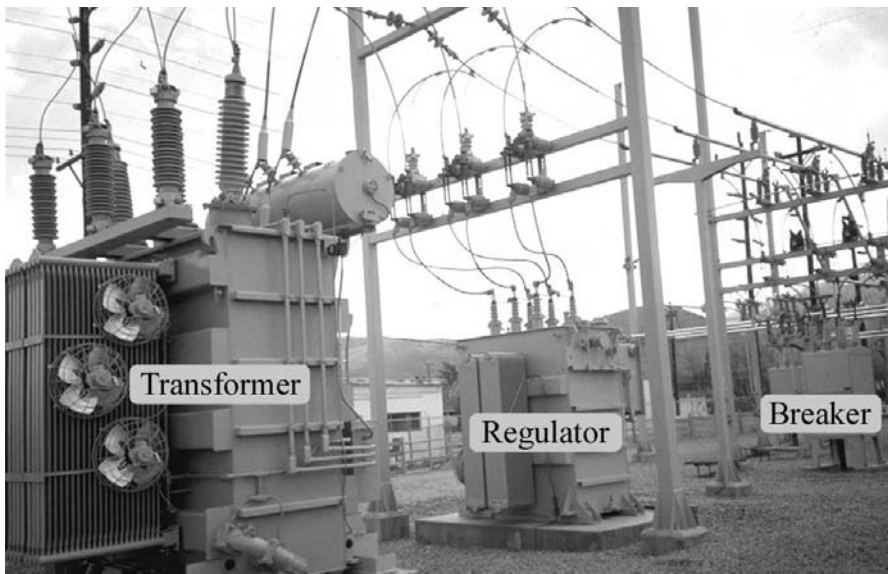

Figure 4-16. Three-phase regulator.



Figure 4-17. Single-phase regulator. Courtesy Alliant Energy.



Figure 4-18. Regulator dial. Courtesy Alliant Energy.

be positioned between two winding taps for half the tap voltage. Figure 4-19 shows the tap changer mechanism with the reactor coil.

*Line Regulators* are sometimes used near the end of long distribution feeders to reregulate the voltage to the customers downstream of the substation regulator. Line regulators make it possible to extend the length of the distribution feeders needed to serve customers at long distances.

Figure 4-20 shows a three-phase load tap changer mechanism inside a regulator. Figure 4-21 shows the switch contacts.

Figure 4-22 shows a *load tap changing transformer* (LTC transformer). LTC transformers combine a step-down transformer with a voltage regulator. LTC transformers offer cost saving advantages. However, two LTC transformers are normally required per substation in order to have load transfer capabilities for regulator maintenance purposes.

### Regulator Controls (Optional Supplementary Reading)

Voltage regulators use an electronic control scheme to automatically operate the raise/lower tap changer. A potential transformer (PT) is used to input actual voltage to the control circuits. A current transformer is used to determine the amount of load on the regulator. The control circuit constantly monitors the voltage level on the regulated side and sends commands to the

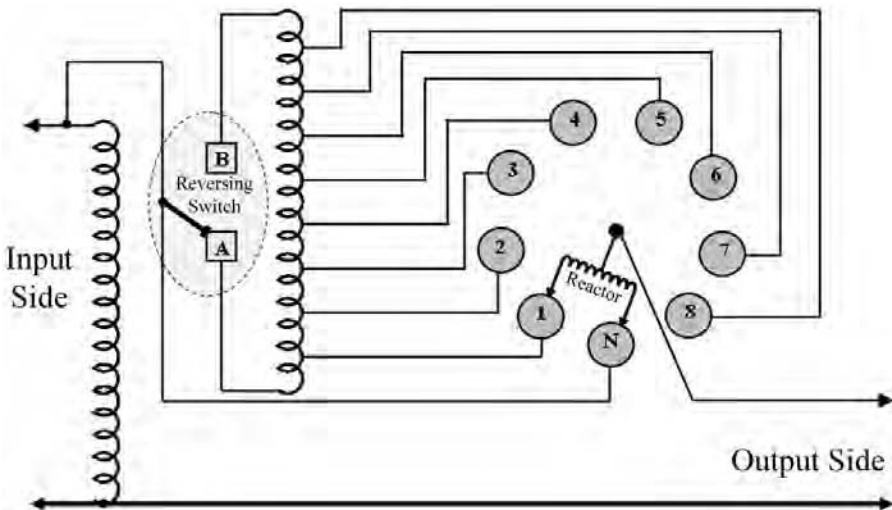

Figure 4-19. Load tap changer.

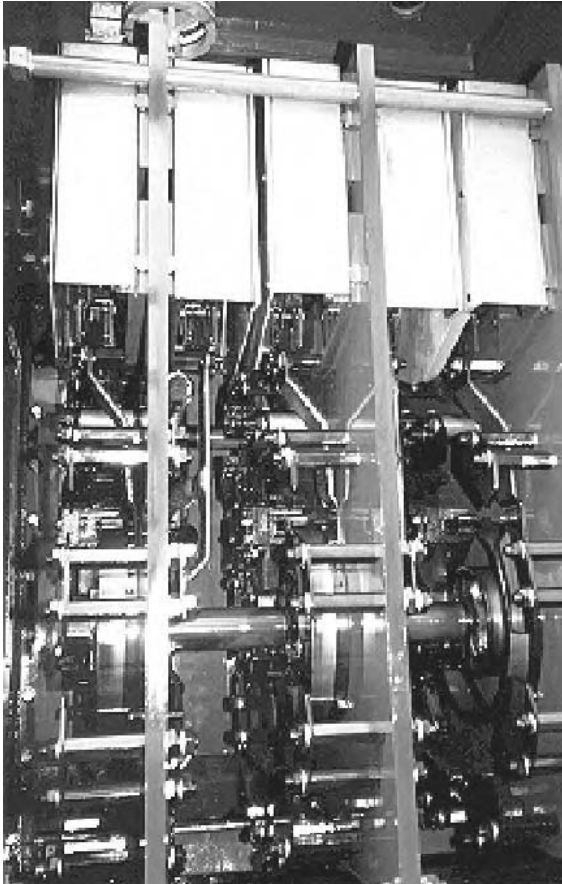

Figure 4-20. Tap changer.

motor operator circuit of the tap changer to raise or lower the regulated voltage based on the control settings. The control settings are programmable by the engineer. The common settings are as follows.

### ***Base Voltage***

This is the desired voltage reference setting used to establish the regulator's base output voltage (e.g., 122 volts is common). When the regulator PT senses the output voltage to be above or below this base setting, the tap changer motor is commanded to raise or lower the output voltage until it comes into the base voltage bandwidth range.

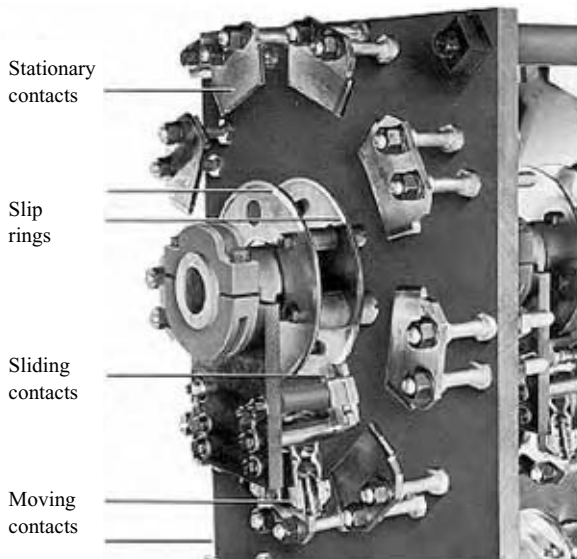

Figure 4-21. Switch contacts. Courtesy Alliant Energy.

### ***Bandwidth***

The base voltage bandwidth setting controls the amount of voltage tolerance above and below the base voltage setting. The regulator does not change taps unless the actual output voltage goes outside this bandwidth setting (e.g., 2 volts bandwidth is normal). For example, if the base voltage is set for 122 Vac, the distribution voltage would have to rise above 124 Vac to cause a command to lower the regulated voltage. Similarly, the distribution voltage would have to go below 120 Vac to cause the LTC to raise the regulated voltage.

### ***Time Delay***

The time delay setting prevents momentary voltage changes and, therefore, reduces the wear and tear on the LTC. For example, the actual distribution voltage would have to exceed the bandwidth for the duration of a preset time delay (i.e., 60 seconds) before the motorized tap changer would begin to operate.

### ***Manual/Auto***

For safety purposes, the manual/auto switch is used to disable the automatic control of the regulator when personnel are working on associated equipment.



Figure 4-22. Load tap changing transformer.

### **Compensation**

The compensation setting is used to control voltage regulation based on conditions some distance down the line. The control is set to compensate for an estimated voltage drop on the distribution line.

## **CIRCUIT BREAKERS**

The purpose of a circuit breaker is to interrupt current flowing in the line, transformer, bus, or other equipment when a problem occurs and the power has to be turned off. Current interruption can be for normal load current, high-*fault current* (due to a short-circuit current or problem in the system) or simply tripped by protective relaying equipment in anticipation of an un-

desirable event or disturbance. A breaker accomplishes this by mechanically moving electrical contacts apart inside an *interrupter*, causing an arc to occur that is immediately suppressed by the high-dielectric medium inside the interrupter. Circuit breakers are triggered to open or close by the protective relaying equipment using the substation battery system.

The most common types of *dielectric* media used to extinguish the arc inside the breaker interrupter are listed below:

- Oil (clean mineral)
- Gas (SF<sub>6</sub> or sulfur hexafluoride)
- Vacuum
- Air

These dielectric media also classify the breaker, such as oil circuit breaker (OCB), gas circuit breaker (GCB), and power circuit breaker (PCB).

Compared to fuses, circuit breakers have the ability to open and close repeatedly, whereas a fuse opens the circuit one time and must be replaced. Fuses are single-phase devices, whereas breakers are normally gang operated three-phase devices. Breakers can interrupt very high magnitudes of current. They can close into a fault and trip open again. They can be controlled remotely. They need periodic maintenance.

## Oil Circuit Breakers

The oil circuit breaker (sometimes called *OCB*) interrupts arcs in clean mineral oil. The oil provides a high resistance between the opened contacts to stop current flow. Figure 4-23 shows an oil circuit breaker. The interrupting contacts (referred to as *interrupters*) are inside the oil filled tanks. Inspection plates are provided to allow close view of the interrupter contacts to determine maintenance requirements.

Oil circuit breakers have the ability to be used in systems that range from low to very high voltage. Oil has a high dielectric strength compared to air. Bushings are usually angled to allow large conductor clearances in the open-air areas and smaller clearances in the oil-encased areas. The main disadvantage of using oil is the environmental hazard if spilled. A maintenance concern for oil breakers is that the oil becomes contaminated with gases during arc suppression. The oil must be filtered or replaced periodically or after a specified number of operations to ensure the oil has a high dielectric strength.





Figure 4-23. Oil circuit breaker.

Figure 4-24 shows a single-tank, three-phase oil breaker's interrupter contacts. Note the wide conductor spacing for the air components and the small conductor spacing in the oil-immersed components. The operating voltage of this breaker is low enough to have all three phases in one tank.

### **SF<sub>6</sub> Gas Circuit Breakers**

Sulfur hexafluoride gas breakers (sometimes called *SF<sub>6</sub>* or *GCBs*) have their contacts enclosed in a sealed interrupting chamber filled with SF<sub>6</sub> gas. SF<sub>6</sub> gas is a nonflammable inert gas that has a very high dielectric strength, much greater than oil. Inert gases are colorless, odorless, and tasteless, and form other chemical compounds with difficulty. These properties enable the



Figure 4-24. Interrupter contacts.

breaker to interrupt current quickly and maintain relatively small equipment dimensions. The operating disadvantage of using SF<sub>6</sub> gas circuit breakers is that the gas turns to liquid at -40°C or -40°F. Maintaining correct gas pressure is also an operational concern. Heaters are usually wrapped around the interrupter chambers in cold weather environments to maintain proper temperature and pressure. Figures 4-25, 26, and 27 are photos of SF<sub>6</sub> gas circuit breakers

### **Vacuum Circuit Breakers**

Vacuum circuit breakers (*VCBs*) extinguish the arc by opening the contacts in a vacuum. (Vacuum has a lower dielectric strength than oil or gas, but higher than air.) These circuit breakers are smaller and lighter than air circuit breakers and typically are found in “metal clad” switch gear of systems under 30 kV. Figure 4-28 shows a typical vacuum circuit breaker.

The contacts are enclosed in an evacuated bottle where no rated current can flow when the contacts separate. When the breaker opens, the arc is put out simply and quickly.

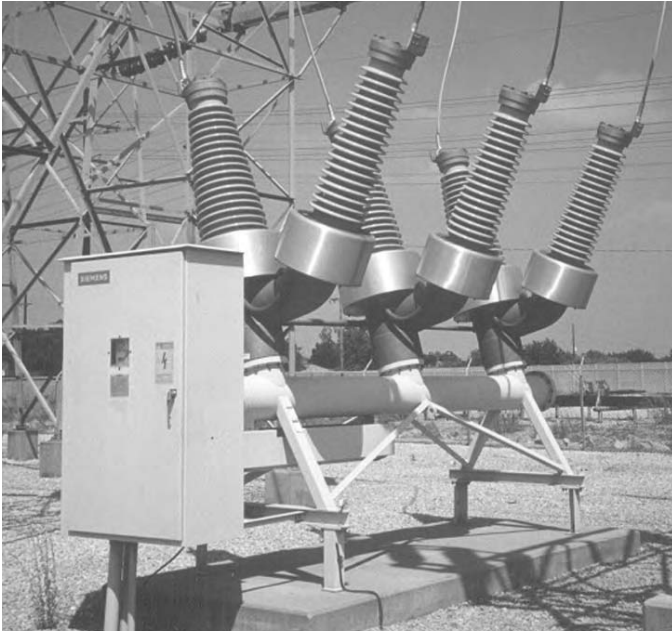

Figure 4-25. Gas circuit breaker.



Figure 4-26. 345 kV Gas breaker.



Figure 4-27. 161 kV Gas breaker. Courtesy Alliant Energy.

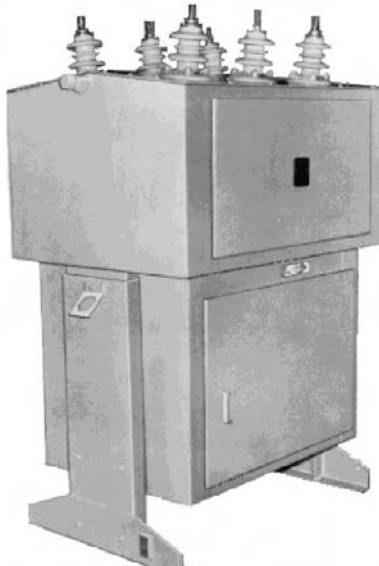

Figure 4-28. Vacuum circuit breaker. Courtesy Alliant Energy.

## Air Circuit Breakers

Since the dielectric strength of air is much less than oil or SF<sub>6</sub> gas, air breakers are relatively large and are usually found in lower-voltage installations. Figure 4-29 shows a 12 kV air breaker used in switch gear.

The very high voltage *air-blast* circuit breaker (not shown) is another type of circuit breaker that is used for subtransmission voltages. Air-blast breakers direct a compressed blast of air across the interrupting contacts to help extinguish the arc. Most air-blast circuit breakers are considered old or obsolete and have been replaced.

## RECLOSERS

Similar to circuit breakers, reclosers provide circuit breaker functionality and they also include basic system-protective relaying equipment to control the automatic opening and reclosing of power circuits. Reclosers are

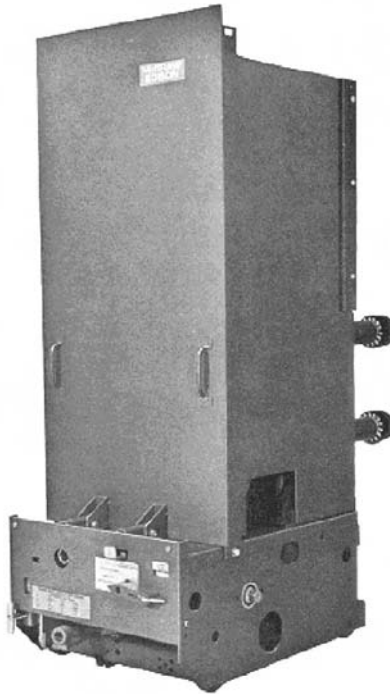

Figure 4-29. Air circuit breaker. Courtesy Alliant Energy.

most commonly used on distribution systems. They offer cost advantages over standard circuit breakers that require separate protective relaying equipment.

The recloser’s incorporated protective relaying equipment can be programmed to trip at specific overcurrent conditions and reclose at specific time intervals. After a circuit trip and a programmable time delay, the recloser automatically reenergizes the circuit. (Please be advised that the automatic reclosing feature can be deactivated.)

Reclosers are commonly used as circuit breakers on distribution lines (see Figure 4-30) or in smaller substations (see Figure 4-31) having low fault currents. Reclosers are typically set to trip and reclose two or three times before a *lock-out* condition occurs. Lock-out means that a person working on the line must manually reset the recloser for power to be restored. If the fault condition clears before the recloser locks-out, the protective relaying resets back to the start of the sequence. Reclosers can also be

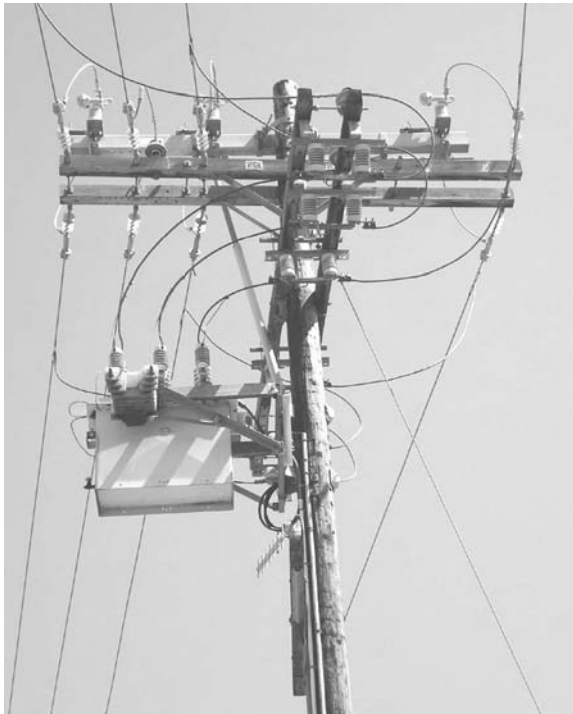

Figure 4-30. Distribution line recloser. Courtesy of Alliant Energy.

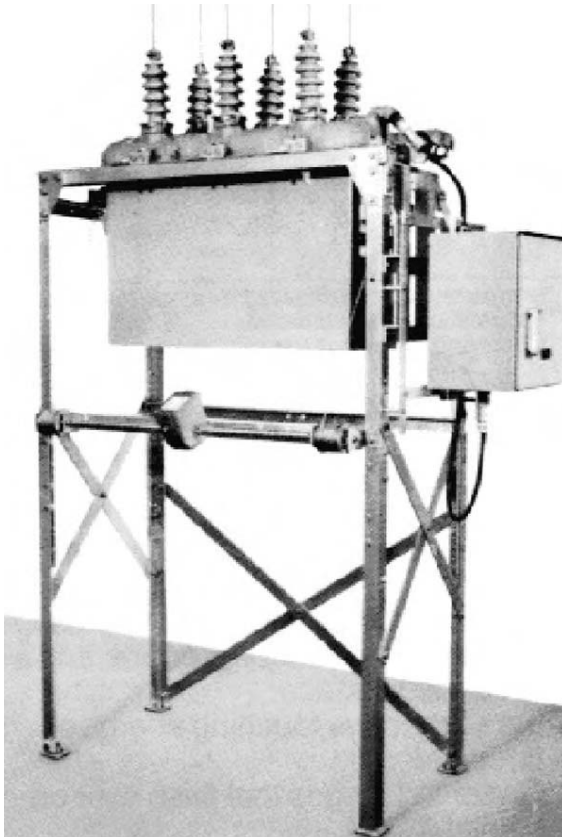

Figure 4-31. Substation recloser. Courtesy of Alliant Energy.

tripped manually. This allows the recloser to be used as a load-break switch or sectionalizer.

## DISCONNECT SWITCHES

There are many purposes for *disconnect switches* in substations and power lines. They are used to isolate or deenergize equipment for maintenance purposes, transfer load from one source to another in planned or emergency conditions, provide visual openings for maintenance personnel (an OSHA requirement for safety against accidental energization), and other reasons. Disconnect switches usually have low current interrupting ratings compared

to circuit breakers. Normally, power lines are first deenergized by circuit breakers (due to their high current interrupting ratings), followed by the opening of the air disconnect switches for isolation.

### Substations

There are many types of substation disconnect switches, such as *vertical break* and *horizontal break* types. Disconnect switches are normally *gang* operated. The term gang is used when all three phases are operated with one operating device. Air disconnect switches are usually opened and closed using control handles mounted at the base of the structure. Sometimes, motor operator mechanisms are attached to the control rods to remotely control their operation. A vertical-break switch is shown in Figure 4-32 and a horizontal-break switch is shown in Figure 4-33.

Some disconnect switches such as the one shown in Figure 4-34 use spring-loaded devices called *arcing rods* to help clear arcs from small currents by whipping open the electrical connection after the switch's main contacts have opened. These spring-loaded devices are also referred to as a



Figure 4-32. Vertical-break switch. Courtesy of Alliant Energy.



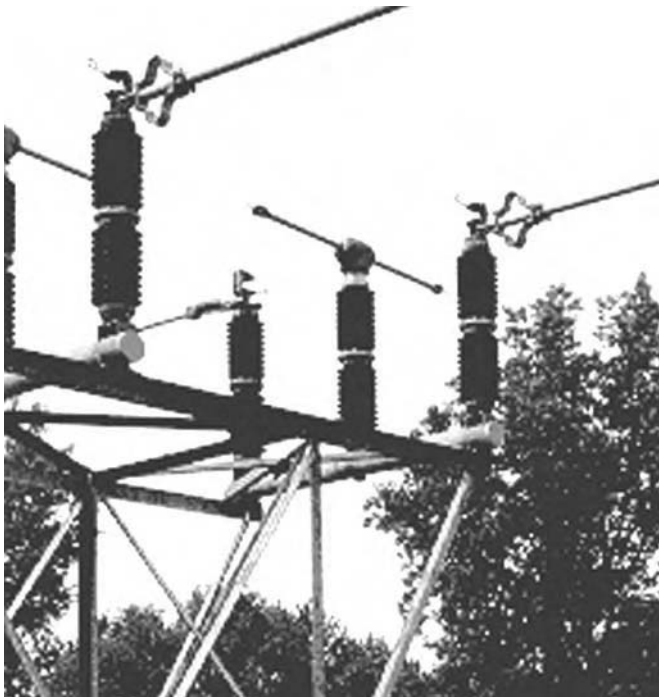

Figure 4-33. Horizontal-break switch. Courtesy of Alliant Energy.

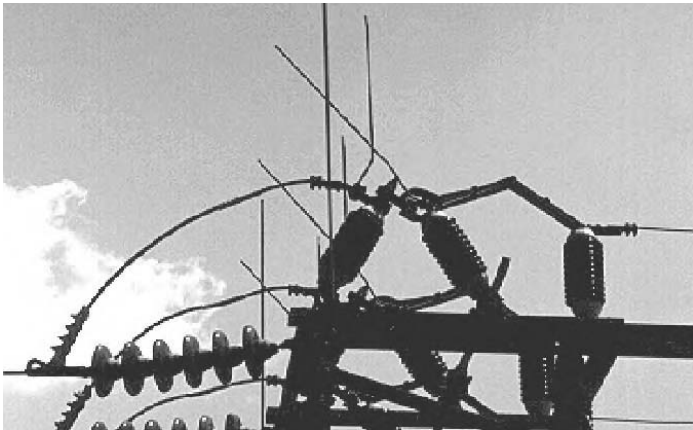

Figure 4-34. Arcing rods.

*whips* or *horns*. The arcing rods increase the switch’s current-opening rating, but usually not enough to open a normal load. They might open a long unloaded line or perhaps a paralleling load transfer operation. Also, arcing rods are sacrificial, in that the rods get pitted in the opening process, rather than the main switch contacts. Rods are cheap and easy to replace.

### Line Switches

Line disconnect switches are normally used to isolate sections of line or to transfer load from one circuit to another. The picture in Figure 4-35 is an example of a typical subtransmission line switch. This particular switch incorporates *vacuum bottles* to help extinguish arcs from interrupting light-load currents.

### LIGHTNING ARRESTERS

Lightning arresters are designed to limit the line-to-ground voltage in the event of lightning or other excessive transient voltage conditions. Some of the older gap-type lightning arresters actually short-circuited the line or equipment, causing the circuit breaker to trip. The breaker would then re-

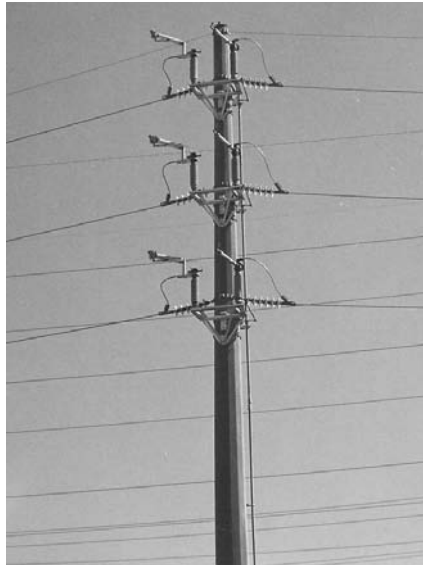

Figure 4-35. Line switch.

close when the transient overvoltage condition was gone. The lightning arrester protects the equipment near the lightning arrester from experiencing high-voltage transient conditions.

For example, suppose an 11 kV lightning arrester is installed on a 7.2 kV line to neutral system. The lightning arrester will conduct if the line-to-neutral voltage exceeds approximately 11 kV. Equipment connected to this distribution system might have a flashover rating of 90 kV. Therefore, the arrester clamped or limited the high-voltage transient and prevented the equipment from experiencing a flashover or insulation failure.

The newer lightning arresters use gapless *metal oxide* semiconductor materials to clamp or limit the voltage. These newer designs offer better voltage control and have higher energy dissipation characteristics.

Aside from the voltage rating for which the arrester is applied, arresters fall into different energy dissipation classes. An arrester might have to dissipate energy up until the circuit breaker clears the line. *Station class* arresters (see Figure 4-36) are the largest types and can dissipate the greatest amount of energy. They are usually located adjacent to large substation power transformers. *Distribution class* arresters (see Figure 4-37) are generously distrib-



Figure 4-36. Station class lightning arrester. Courtesy of Alliant Energy.



Figure 4-37. Distribution class. Courtesy of Alliant Energy.

uted throughout the distribution system in areas known to have high lightning activity. They can be found near distribution transformers, overhead of underground transition structures, and along long distribution lines. *Intermediate class* arresters are normally used in substations that do not have excessive short-circuit current. Residential and small commercial customers may use *secondary class* arresters to protect large motors, sensitive electronic equipment, and other voltage-surge-sensitive devices connected to their service panel.

## ELECTRICAL BUS

The purpose of the electrical *bus* in substations is to connect equipment together. A bus is a conductor, or group of conductors, that serves as a common connection between two or more circuits. The bus is supported by station post insulators. These insulators are mounted on the bus structures. The bus can be constructed of 3–6 inch rigid aluminum tubing or wires with insulators on both ends, called a “strain” bus.

The *buswork* consists of structural steel that supports the insulators that support the energized conductors. The buswork might also include air disconnect switches. Special bus configurations allow for transferring load from one feeder to another and to bypass equipment for maintenance.

Figure 4-38 is an example of typical buswork found in substations.

## CAPACITOR BANKS

Capacitors are used to improve the operating efficiency of electric power systems and help transmission system voltage stability during disturbances.



Figure 4-38. Examples of a typical electrical bus.

Capacitors are used to cancel out the lagging current effects from motors and transformers. Capacitors can reduce system losses and help provide voltage support. Another benefit of capacitors is that they can reduce the total current flowing through a wire, thus leaving capacity in the conductors for additional load.

Capacitor banks can be left online continuously to meet steady-state reactive power requirements or they can be turned on or off to meet dynamic reactive requirements. Some capacitor banks are switched seasonally (i.e., to accommodate air conditioning load in the summer) and others are switched daily to accommodate industrial loads.

Capacitor banks can be switched manually, automatically, locally or remotely. For example, system control center operators commonly switch substation capacitor banks on and off to meet load requirements or system stability reactive demand requirements. Providing capacitive support maintains good system voltage and reduces system losses.

### **Substation Capacitor Banks**

Figure 4-39 shows a typical substation capacitor bank. Actually, this picture shows two three-phase capacitor banks (one in the foreground and one in

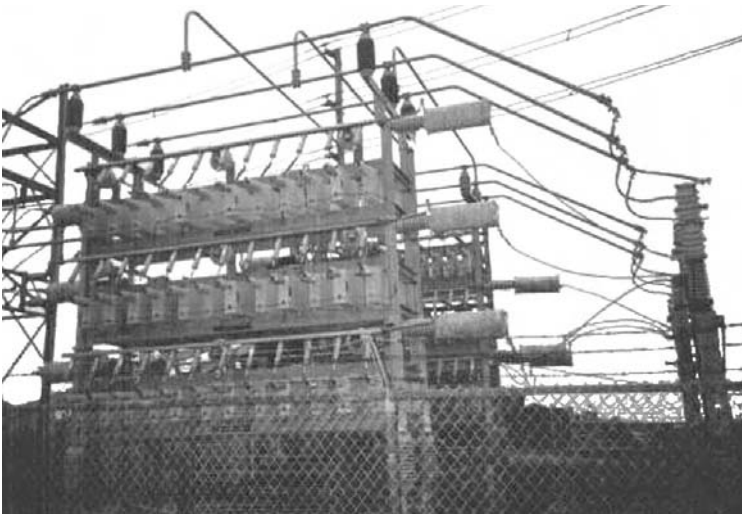

Figure 4-39. Substation capacitor bank.

the background). The vertical circuit breakers on the far right of the picture provide the switching function of these substation capacitor banks.

### Distribution Capacitor Bank

Capacitor banks are installed on distribution lines to reduce losses, improve voltage support, and provide additional capacity on the distribution system (See Figure 4-40). Actually, reducing distribution system losses with capacitors is very effective since that also reduces transmission losses.

The closer a capacitor is installed to the actual inductive load itself, the more beneficial it is. For example, if capacitors are installed right at the motor terminals of an industrial load, losses are prevented in the lines feeding the motor, distribution losses are prevented, and transmission and generation losses are prevented.

### REACTORS

*Reactor* is another name for a high-voltage inductor. They are essentially one-winding transformers. Reactors are used in electric power systems for two main reasons. First, reactors are used in a shunt configuration (i.e., line



Figure 4-40. Distribution capacitor bank.

to ground connections), to help regulate transmission system voltage by absorbing surplus reactive power (VARs) from generation or *line charging*. Line charging is the term used to describe the capacitance effects of long transmission lines since they are essentially long skinny capacitors (i.e., two conductors separated by a dielectric—the air). Second, they are connected in series to reduce fault current in distribution lines.

Reactors can be open-air coils or coils submerged in oil. Reactors are available in either single-phase or three-phase units.

### **Shunt Reactors—Transmission**

The electrical characteristics and performance of long, high-voltage transmission lines can be improved through the use of shunt reactors. Shunt reactors are used on transmission lines to help regulate or balance reactive power flowing in the system. They can be used to absorb excess reactive power. Reactors are normally disconnected during heavy load conditions and are

connected during periods of low load. Reactors are switched online during light load conditions (i.e., late at night or early morning) when the transmission line voltage tends to creep upward. Conversely, shunt capacitors are added to transmission lines during high-load conditions to raise the system voltage.

Another application of shunt reactors is to help lower transmission line voltage when energizing a long transmission line. For example, suppose a 200 mile, 345 kV transmission line is to be energized. The line-charging effect of long transmission lines can cause the far-end voltage to be on the order of 385 kV. Switching on a shunt reactor at the far end of the line can reduce the far-end voltage to approximately 355 kV. This reduced far-end voltage will result in a lower transient voltage condition when the far-end circuit breaker is closed, connecting the transmission line to the system and allowing current to flow. Once load is flowing in the line, the shunt reactor can be disconnected and the load will then hold the voltage in balance.

Figure 4-41 shows a 345 kV, 35 MVAR three-phase shunt reactor used to help regulate transmission voltage during light load conditions and during the energization of long transmission lines.

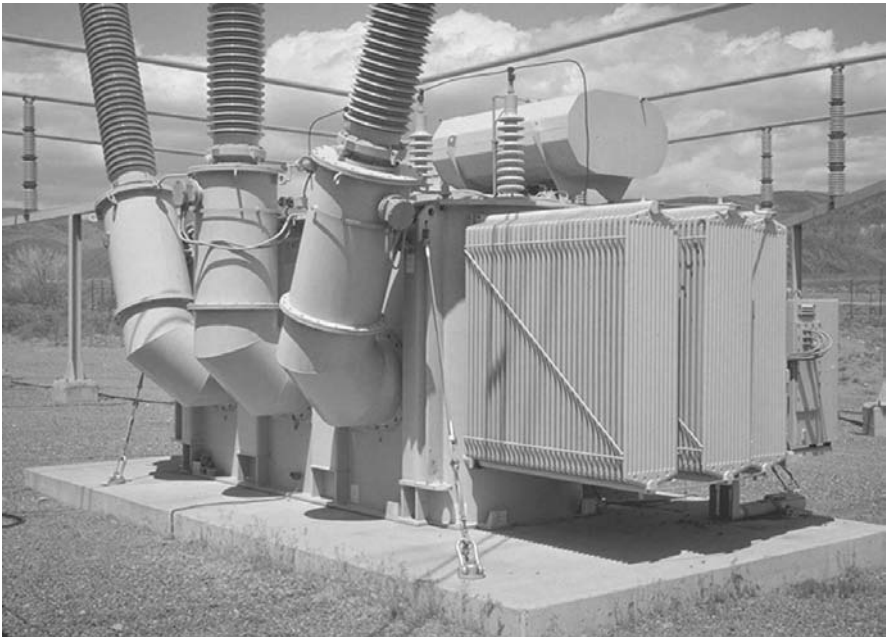

Figure 4-41. Reactor.



## Series Reactors—Distribution

Distribution substations occasionally use series reactors to reduce available fault current. Distribution lines connected to substations that have several transmission lines or are near a generation plant might have extremely high short-circuit fault current available if something were to happen out on the distribution line. By inserting a series reactor on each phase of each distribution line, the fault current decreases due to the fact that a magnetic field has to be developed before high currents flow through the reactor. Therefore, the circuit breaker trips the distribution line before the current has a chance to rise to full magnitude. Otherwise, the high fault current could cause excessive damage to consumers' electrical equipment.

## STATIC VAR COMPENSATORS

The *Static VAR Compensator* (SVC) is a device used on ac transmission systems to control power flow, improve transient stability on power grids, and reduce system losses (see Figure 4-42). The SVC regulates voltage at its terminals by controlling the amount of reactive power injected or absorbed from the power system. The SVC is made up of several capacitors and inductors (i.e., reactors) and an electronic switching system that enables ramping up or down reactive power support. When system voltage is low,



Figure 4-42. Static VAR compensator. Courtesy of Jeff Selman.

the SVC generates reactive power (i.e., is SVC capacitive). When system voltage is high, the SVC absorbs reactive power (i.e., is SVC inductive). The variation of reactive power is performed by switching three-phase capacitor banks and inductor banks connected on the secondary side of a coupling transformer.

## CONTROL BUILDINGS

Control buildings are commonly found in the larger substations. They are used to house the equipment associated with the monitoring, control, and protection of the substation equipment (i.e., transformers, lines, and bus). The control building interior showing in Figure 4-43 contains protective relaying, breaker controls, metering, communications, batteries, and battery chargers.

The protective relays, metering equipment, and associated control switches are normally mounted on relay racks or panels inside the control building. These panels also include status indicators, sequence-of-events recorders, computer terminals for system control communications, and oth-

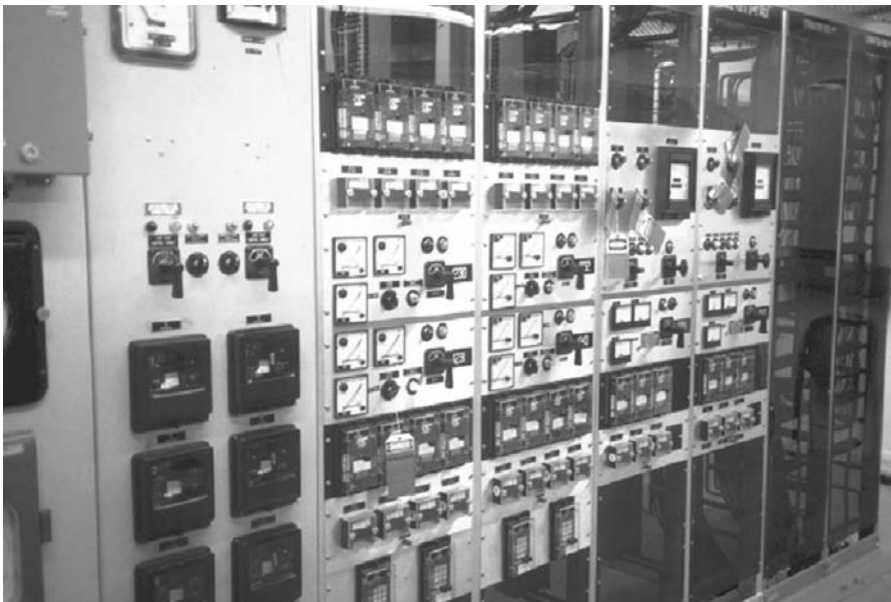

Figure 4-43. Control building interior.

er equipment that requires environmental conditioning. CT's and PT's cables from the outside yard equipment also terminate in the control building in cabinets or relay panels.

The environmental conditioning in a control building usually consists of lighting, heating, and air conditioning to keep the electronic equipment operating reliably.

Control buildings house important *sequence-of-events recorders* (SOEs) needed to accurately track the operation of all substation equipment activity, primarily just before, during, and after system disturbances. Accurate time stamps are placed on each event for follow-up analysis. Some of the items tracked include relay operations and circuit breaker trip information. The recorder produces a data file or paper record of all events that occurred during a major disturbance. This information is later analyzed with SOE data from other substations (including those from other utilities) to determine what went right or wrong, and what changes are needed to avoid similar disturbances in the future. This information is time stamped by highly accurate satellite clocks. This enables one to analyze an interconnected power system disturbance to determine whether the equipment operated properly and what recommendations are needed.

## PREVENTATIVE MAINTENANCE

There are many ways to perform preventative maintenance on electric power systems. Scheduled maintenance programs, site inspections, and routine data collection and analysis are very effective. An enhanced or a more effective means of performing preventative maintenance is *predictive maintenance*. Sometimes this is called "*condition-based maintenance*," when maintenance is based on measured or calculated need rather than just a schedule. Predictive maintenance can identify potentially serious problems before they occur. Two very effective predictive maintenance programs or procedures are *infrared scanning* and *dissolved gas analysis* testing.

### Infrared Technology

*Infrared technology* has improved maintenance procedures significantly. Temperature-sensitive cameras are used to identify hot spots or hot hardware. "Hot" in this case refers to excessive heat opposed to hot referencing "energized" equipment. Loose connectors, for example, can show up on infrared scans very noticeably. Loose connections can be very hot due to the

high-resistance connection compared to the temperature of surrounding hardware, indicating that a problem exists. Extreme hot spots must be dealt with immediately before failure occurs.

Infrared technology is a very effective *predictive maintenance* technique. Infrared scanning programs are used by most electric utilities. Scanning many types of equipment such as underground, overhead, transmission, distribution, substation, and consumer services is a cost-effective means of preventative maintenance.

## Dissolved Gas Analysis

*Dissolved gas analysis* (DGA) is another very effective predictive maintenance procedure that is used to determine the internal condition of a transformer. Taking small oil samples periodically from important transformers allows one to accurately track and, through trend analysis, determine if the transformer experienced arcs, overheating, corona, sparks, and so on. These types of internal problems produce small levels of various gases in the oil. Specific gases are generated by the certain problem conditions. For example, if an oil analysis finds existence of abnormally high levels of carbon dioxide and carbon monoxide gases, this might indicate some overheating of the paper insulation used around copper wires in the transformer coils. Acetylene gas might indicate that arcing has occurred inside the transformer.

Samples are taken periodically and the gas analysis compared to previous samples in a trend-analysis procedure. Significant changes in the parts per million (PPM) values of the various gases could indicate that problems exist inside the transformer. Critical transformers (i.e., generator step-up or transmission transformers) might have equipment to continuously monitor or perhaps samples are taken every 6 months. Less critical transformers might have samples taken every year or two.

Once it has been determined that a transformer has a gas problem, it is immediately taken out of service and internally inspected. Sometimes, the problems can be repaired in the field; for example, loose bushing/jumper connections causing overheating can be tightened. Sometimes, the problem cannot be adequately determined, in which case the transformer has to be rebuilt. Repairing a transformer can be very costly and time-consuming. However, it is much less costly to repair a transformer under controlled conditions than it is to face the consequences of a major transformer failing while in service.

---

# DISTRIBUTION

---

## CHAPTER OBJECTIVES

- ✓ *Explain the basic concepts of overhead and underground distribution systems*
- ✓ *Discuss how distribution feeders are operated radially*
- ✓ *Discuss grounded wye and delta distribution feeders and laterals*
- ✓ *Discuss the advantages and disadvantages of wye versus delta*
- ✓ *Explain how three-phase transformer banks are connected*
- ✓ *Explain how distribution transformers produce 120/240 Vac*
- ✓ *Describe the different underground system components*
- ✓ *Explain secondary service wire connections*

## DISTRIBUTION SYSTEMS

Distribution systems like that shown in Figure 5-1 are responsible for delivering electrical energy from the distribution substation to the service-entrance equipment located at residential, commercial, and industrial con-



Figure 5-1. Distribution systems. *Source:* Fotosearch.

sumer facilities. Most distribution systems in the United States operate at primary voltages between 12.5 kV and 24.9 kV. Some operate at 34.5 kV and some operate at low-voltage distribution such as 4 kV. These low-voltage distribution systems are being phased out. Distribution transformers convert the *primary* voltage to *secondary* consumer voltages. This chapter discusses distribution systems between the substation and consumer.

## Distribution Voltages

Table 5-1 shows the various distribution system voltages used in North America. This table is not absolute; some power companies may designate their system voltages differently.

*System voltage* is a term used to identify whether reference is being made to *secondary* or primary distribution systems. Residential, commercial, and small industrial loads are normally served with voltages under 600 volts. Manufacturers have standardized the provision of insulated wire to have a maximum 600 Vac rating for “secondary” services. For example, household wire such as extension cords has a 600 Vac insulation rating. Other than changing the plugs and sockets on either end, one could use this wire for higher voltages such as 240 Vac.

The 34,000 Vac system voltage is used differently among electric power companies. Some companies use 34.5 kV distribution system voltages to connect service transformers in order to provide secondary voltages to consumers, whereas other companies use 34.5 kV power lines between distribution substations and not for consumers.

There are several common distribution system voltages between secondary and 34.5 kV used in the industry. For example, many power companies have standardized distribution at 12.5 kV while others use 25 kV. Some companies use 13.2 kV, 13.8 kV, 14.4 kV, 20 kV, and so on. There are several areas still using 4.16 kV systems. These lower-voltage distribution systems are quickly being phased out due to their high losses and short-distance capabilities.

The *voltage category* for distribution is usually *high voltage* (HV). Utilities often place HV warning signs on power poles and other associated electrical equipment.

Table 5-1. Common distribution voltages

System voltage	Voltage class	Nominal voltage (kV)	Voltage category
Secondary	Under 600	0.120/0.240/0.208 0.277/0.480	Low voltage (LV)
Distribution	601–7200	2.4–4.16	Medium voltage (MV)
	15,000	12.5–14.4	High voltage (HV)
	25,000	24.9	
Distribution or subtransmission	34,500	34.5	

### Distribution Feeders

Distribution lines (sometimes called *feeders*) like that shown in Figure 5-2 are normally connected *radially* out of the substation. Radially means that only one end of the distribution powerline is connected to a source. Therefore, if the source end becomes opened (i.e., deenergized) the entire feeder is deenergized and all the consumers connected to that feeder are out of service.

The transmission side of the substation normally has multiple transmission lines feeding the substation. In this case, the loss of a single transmission line should not deenergize the substation and all radial distribution feeders should still have a source of power to serve all consumers. The operative word is “should.” Usually, system-protective relays control the switching operation of substation circuit breakers. There are rare occasions when the protective relaying equipment fails to perform as intended and outage situations occur.

Distribution feeders might have several disconnect switches located throughout the line. These disconnect switches allow for load transfer capability among the feeders, isolation of line sections for maintenance, and visual openings for safety purposes while working on the lines or other high-voltage equipment. Even though there might be several lines and open/closed disconnect switches connected throughout a distribution system, the distribution lines are still fed radially.

### Wye Versus Delta Feeders and Connections

This section compares the two main distribution feeder construction alternatives, wye (Figure 5-3) and delta (Figure 5-4). Most of the three-phase dis-

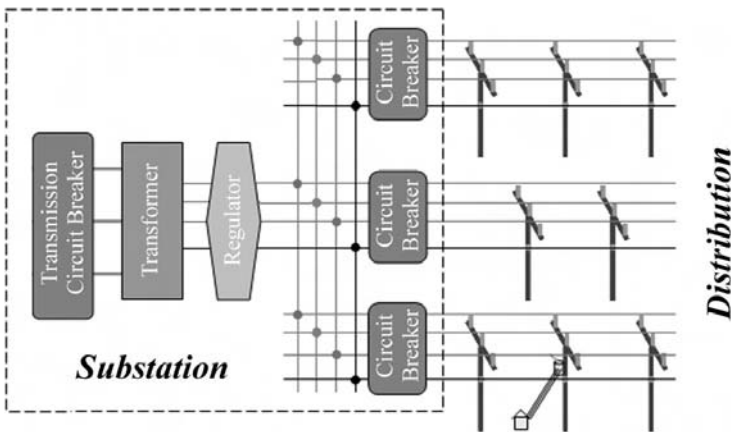

Figure 5-2. Distribution feeders.



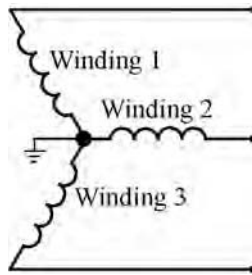

Figure 5-3. Wye connection.

tribution feeders and transformer connections use the wye system alternative because it offers more advantages than disadvantages. Although delta distribution systems do exist, much of the delta distribution has been converted to wye.

The wye connection has one wire from each coil connected together to form the *neutral*. Most of the time, this neutral is *grounded*. Grounded implies that the three common wires are connected together and then connected to a ground rod, primary neutral, or ground grid. The grounding system provides a low-resistance connection to earth. Grounding gives earth an electrical reference; in the case of the wye connection, this neutral reference is zero volts. (Chapter 9 covers grounding in more detail and includes some of the safety issues associated with proper grounding.)

The earth surface is conductive most of the time. Depending on the type of soil (rich fertile soil vs. granite rock) and the condition of the soil (wet vs. dry), earth can be a very good conductor or a very poor conductor (i.e., a very good insulator) or both, depending on the season. Giving the distribution power line a reliable earth connection with the neutral zero voltage reference improves such things as safety, voltage stability, and protection system design.

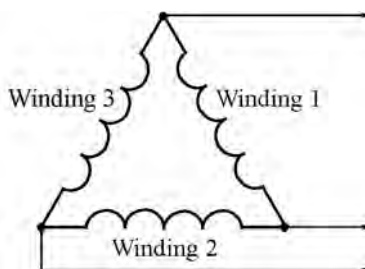

Figure 5-4. Delta connection.

There are many applications for the wye or delta configuration or connection reference. Starting with the distribution substation, the concept of wye or delta applies to the low-voltage side of the substation distribution transformer. (Most of them are grounded-wye connected.) Next, the distribution feeder can be wye or delta. (Most are wye, indicating a four-wire power line having line-to-line voltages and line-to-neutral voltages.) Each consumer that has a three-phase service transformer has to reference the high-voltage side of the transformer bank and the low-voltage side configuration. (The common adopted standard is the wye–wye configuration distribution transformer bank.) Properly connecting three-phase loads to a distribution system involves knowing how the load equipment is supposed to be connected per the manufacturer (i.e., wye or delta) and how the distribution line is configured (i.e., wye or delta). There are multiple ways to configure three-phase equipment; however, the preferred means is by having four-wire wye equipment connected to four-wire wye–wye distribution transformers on a four-wire wye primary. This arrangement provides a highly preferred common neutral grounding system.

Both wye and delta configurations have distinguishable advantages and disadvantages when it comes to transmission or distribution systems. Transmission and subtransmission lines are built as three-phase, three-wire lines. The ends of the transmission lines are connected to either delta or *source-grounded wye* transformer connections. “Source-grounded wye” connection means that the transmission transformer in the substation is a four-wire wye transformer that has the three phases connected to the line conductors and the neutral connected to the substation *ground grid*. Note that the neutral is not provided on transmission lines. It is not necessary to provide the neutral on the transmission line because all three phases are assumed to have balanced currents and there would be no current flowing in the neutral conductor when the currents are balanced. With respect to distribution lines, most systems use grounded-wye connections and current is usually present in the neutral because the three phase currents are normally not balanced. Three-wire delta distribution lines exist, primarily in rural areas where a neutral is not present. Those lines are more vulnerable to stray currents and voltages through the earth as the earth tries to balance the current flow. The preferred standard for distribution is the grounded-wye configuration.

From the perspective of distribution systems, the following predominant advantages and disadvantages apply.

### ***Advantages of Grounded-Wye Configuration***

- Common ground reference. The power company’s primary distribution neutral is grounded, the service transformer is grounded, and the

customer's service entrance equipment is grounded, all to the same reference voltage point.

- Better voltage stability. The common ground improves voltage stability because the reference point is consistent. This also improves power quality.
- Lower operating voltage. Equipment is connected to the “line-to-neutral (L-N)” potential instead of the higher voltage “line-to-line (L-L)” potential.
- Smaller equipment size. Since the equipment is connected at a lower voltage (line-to-neutral instead of line-to-line), bushings, spacing, and insulation requirements can all be smaller.
- Can use single-bushing transformers. Since one side of the transformer winding is connected to the grounded neutral, that connection does not need a bushing. Instead, single-bushing transformers have an internal connection to the neutral.
- Easier to detect line-to-ground faults. Should a phase conductor fall to the ground, a tree make contact with a phase, and so on, the short-circuit overcurrent condition that would result significantly increases the current in the neutral back at the substation. Therefore, merely measuring the neutral overcurrent condition at the substation with a current transformer (CT) connected to the transformer neutral determines whether a line-to-ground fault condition exists out on the distribution feeder. This overcurrent condition initiates a trip signal to the feeder circuit breaker. (Note: in the case of delta configurations, there is no true grounded neutral, making it much harder to detect line to ground faults.)
- Better single-phase protection with fuses. Fuses on transformers and distribution feeder lateral extensions clear faults much more reliably than fuses connected in delta configurations. Since deltas have equipment connected line to line, a line-to-ground fault could blow one or more fuses. Fuses in delta circuits can be fatigued or weakened from faults on other phases. Therefore, it is a common practice on delta systems to replace all three fuses in case one or more were weakened from a line-to-ground fault.

### ***Disadvantages of Grounded-Wye Configuration***

- Requires four conductors. Delta systems require only three conductors for three-phase power. That is an advantage of the delta configuration that resulted in the majority of distribution lines being built with delta

configurations early in the process of electrifying America. Today, most of these lines have been converted to four-wire wye systems due to the advantages that wye has over delta.

### ***Advantages of Delta Configuration***

- Three conductors versus four (i.e., less expensive to construct)
- Power quality enhancement. The third-order harmonics are eliminated due to a natural cancellation. In other words, the 60 Hz power sine wave is cleaner by nature. The 120 degree phase shift between phases acts to cancel out some unwanted interference voltages.
- Lightning performance. One could argue that sometimes the isolated conductors in a delta from ground configuration minimize the effect that lightning has on a system. However, lightning arresters in delta systems are still connected line to neutral.

### ***Disadvantages of Delta Configuration***

- No ground reference. Service voltage may be less stable, fuse protection may be less effective, and there might be more overall power quality issues.
- Stray currents. Distribution transformers can cause stray currents to flow in the earth when their low-voltage secondary side is grounded. Although the primary side of the distribution transformer is not grounded, the secondary side is grounded. Therefore, a small but measurable voltage is inadvertently connected to ground, causing stray currents to exist.
- Unbalanced currents. Three-phase transformer banks can regulate the primary voltage or try to equalize the primary voltage. The delta connections along with the transformers having the same turns ratios can cause the primary voltage to equalize. This can result in additional stray currents or unbalanced currents in the feeder.

Comparing all the advantages and disadvantages, the multigrounded neutral, four-wire wye-distribution feeder is the preferred method. Most of the delta distribution lines have been replaced with grounded wye systems, but some deltas still exist. The preference is for power companies to use grounded wye systems on all distribution systems. However, converting delta to wye does require the cost of adding a conductor. Conversion can be a slow process.

## Line-to-Ground Versus Line-to-Neutral Voltages (Optional Supplementary Reading)

Grounded wye systems have two voltages available for use. These two voltages are related mathematically by the  $\sqrt{3}$ . Equipment can be connected either “line to line” (L-L) or “line to neutral” (L-N). The L-N voltage is less than the L-L voltage. The neutral side of the L-N voltage is normally connected to earth by means of ground rods or grounding wires. The lower-voltage L-N connection is the normally used connection. Therefore, distribution power is transported efficiently in wye distribution systems, yet consumer transformers are connected to a lower-voltage source.

For example, 12.5 kV L-L distribution systems have a 7.2 kV L-N voltage available for transformer connections (12.5 kV divided by  $\sqrt{3}$  equals 7.2 kV).

The term “line” is interchangeable with the term “phase.” It is correct to say either “line to line” or “phase to phase.” It is also acceptable to say “line to neutral” or “phase to neutral.”

## Wye Primaries Overhead

Wye-connected primary distribution lines consist of three phases and a neutral, as shown in Figures 5-5 and 5-6. The neutral is grounded at every pole in most systems. (Note: some rural grounded-wye systems might follow the local practice of grounding a minimum of five grounds per mile and not every pole.) One can identify a wye primary configuration by the way single-phase transformers are connected to the line. One of the transformer bushings will be grounded. Examining the wires connected to the transformer bushings helps one determine if the transformer is connected line to ground or line to line. Some wye-connected transformers only have one high-voltage bushing. In that case, the neutral side of the primary winding is internally connected to the tank ground lug that is connected to the primary neutral. (Special note: single-phase transformers can be connected line to line. They do not have to be connected line to neutral. Actually, this is a common occurrence where a delta distribution line is converted to a grounded wye line. The line-to-line transformers are left connected line to line.)

Lateral single phase feeders branching off wye primaries usually consist of one phase conductor and a neutral conductor, as shown in Figure 5-7. At the branch point, the neutral will be grounded and continually grounded along the lateral. Note: a continually grounded neutral is referred to as a *multigrounded neutral* (MGN). Figure 5-8 shows a transformer connected to a single-phase lateral.



Figure 5-5. Wye distribution.

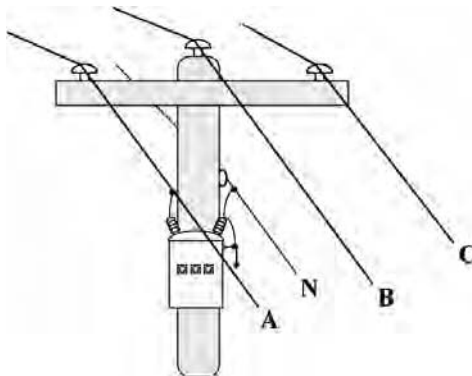

Figure 5-6. Wye three-phase feeder. Courtesy of Alliant Energy.

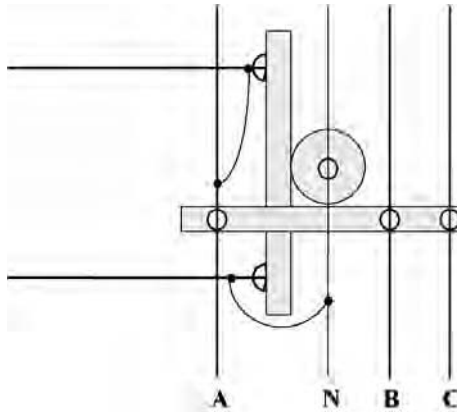

Figure 5-7. Wye one-phase lateral. Courtesy of Alliant Energy.

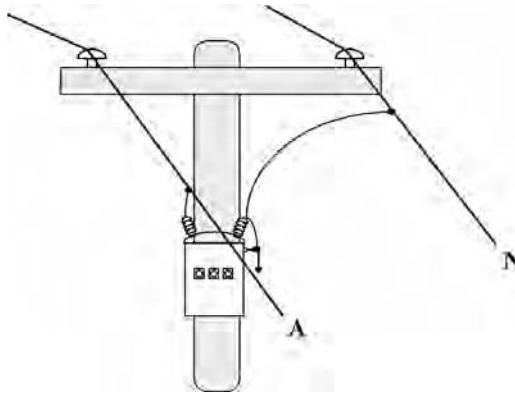

Figure 5-8. One-phase lateral. Courtesy of Alliant Energy.

### Delta Primaries

Delta primary distribution lines use three conductors (one for each phase) and no neutral. Single-phase transformers must have two high-voltage bushings and each bushing must connect directly to different phases. Since delta primaries do not have primary neutrals, the transformer tank grounds and lightning arrester grounds must be connected to a ground rod at the base of the pole with a ground wire along the side of the pole. Delta primaries and fused laterals require single-phase transformers to be connected phase to phase. Figures 5-10 to 5-12 show delta primary distribution



Figure 5-9. Delta distribution.

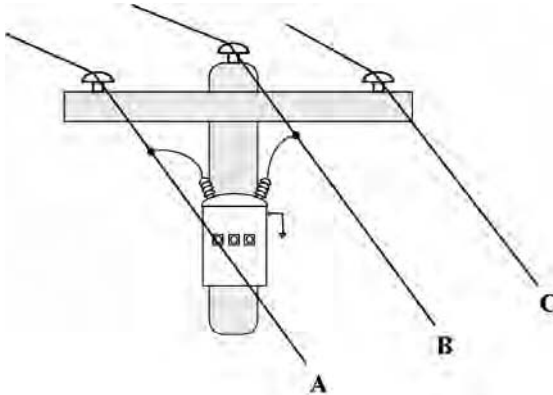

Figure 5-10. Delta three-phase feeder. Courtesy of Alliant Energy.



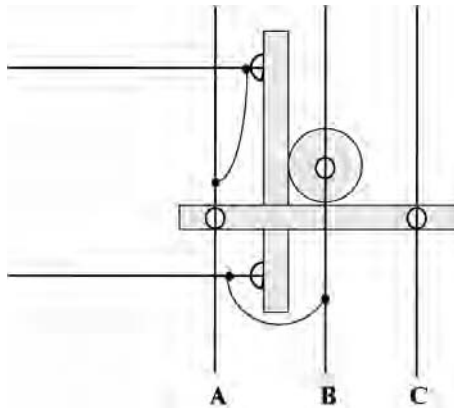

Figure 5-11. Delta one-phase lateral. Courtesy of Alliant Energy.

lines. The single-phase delta laterals consist of two phase conductors and no neutral.

**TRANSFORMER CONNECTIONS (OPTIONAL SUPPLEMENTARY READING)**

This section discusses the most common transformer configurations: phase to neutral (i.e., line to ground) for single-phase connections and wye–wye for three-phase transformer-bank connections. The most common connection for a distribution transformer, single phase or three phase, is phase to

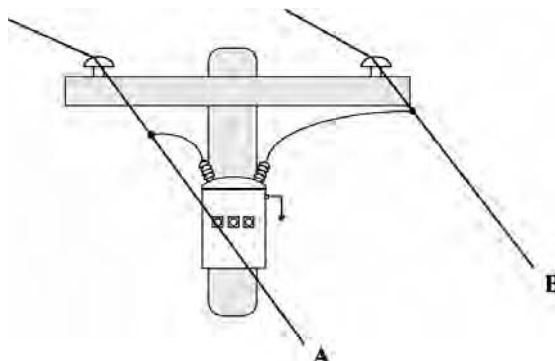

Figure 5-12. One-phase lateral. Courtesy of Alliant Energy.

ground (i.e., line to ground). Figure 5-13 shows a one-phase transformer installation.

### **Distribution Transformers: Single-Phase**

Since the standard residential service voltage is 120/240 Vac, most distribution transformers have turns ratios that produce the 120/240 Vac on their secondary or low-voltage side. Service wires are connected between the distribution transformer secondary-side bushings and the consumer's service-entrance equipment.

#### ***Transformer Secondary Connections: Residential***

In order to produce the two 120 Vac sources (to make up the 120 Vac and the 240 Vac service) for the residential consumer, the distribution transformer has two secondary windings.

Figure 5-14 shows how the 120 Vac and the 240 Vac service is provided from the secondary side of the distribution transformer. Figure 5-15 shows the transformer connections. This is the most standard connection configuration for residential consumers. This single-phase transformer has



Figure 5-13. Transformer connections.

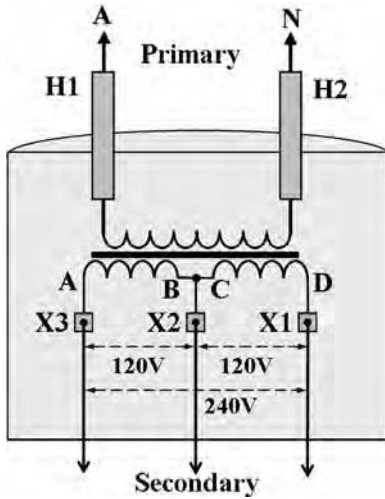

Figure 5-14. Standard two-bushing transformer.

the two 120 Vac low-side voltage terminals connected in series with a neutral connection in the middle. This transformer supplies 120/240 volts single-phase service to residential customers. Note the two secondary windings in series.

Note the bushing nomenclature. The H1 and H2 markings identify the high-voltage side connections (i.e., bushings). X1 and X2 identify the low-

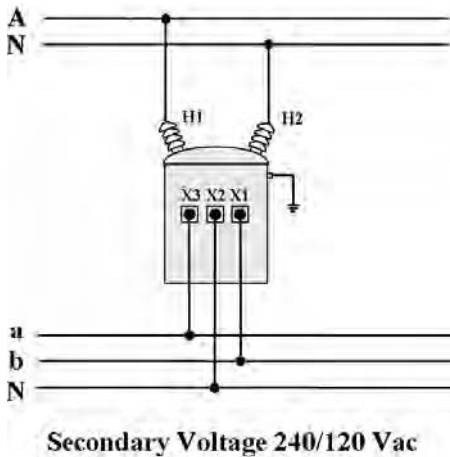

Figure 5-15. Two-bushing transformer connections. Courtesy of Alliant Energy.

voltage side connections (i.e., bushings). This is common practice for all voltage classes including very high voltage transformers.

Example, suppose the distribution feeder voltage is 12.5 kV line to line, which has a line-to-neutral voltage of 7.2 kV (hence, divide the line-to-line voltage by the square root of three). Using transformers with 60:1 turns ratios on each of the two secondary windings, the secondary voltage becomes 120 volts (7200 V divided by 60). The two secondary windings together produce 240 volts.

### Single-Phase One-Bushing Transformer

Figure 5-16 is also a single-phase transformer; however, one high-side bushing has been eliminated. Since one side of the primary winding is connected to neutral anyway (see Figure 5-17), the connection is made internally. This is referred to as a single-bushing transformer. It has a terminal lug for the neutral or ground connection. In some transformers, the X2 bushing is also internally connected to the ground connection.

### Distribution Transformers: Three-Phase

Three single-phase transformers are used to produce three-phase service for commercial and industrial consumers. The small commercial and industrial consumers are normally served with 208/120 Vac three-phase service. The larger commercial and industrial consumers are normally served with

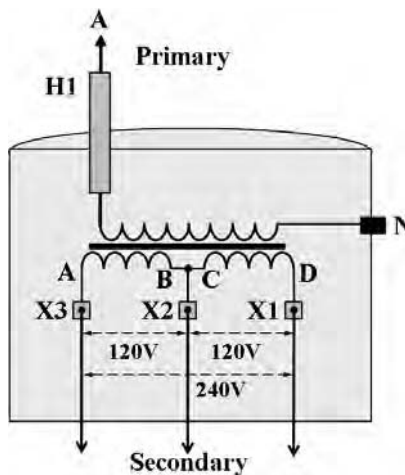

Figure 5-16. Standard one-bushing transformer.

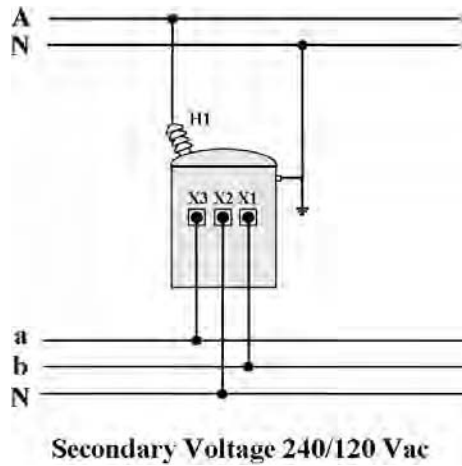

Figure 5-17. One-bushing transformer connections. Courtesy of Alliant Energy.

480/277 Vac three-phase service. This section discusses how the three-phase service voltages are produced. Figure 5-18 shows a typical three-phase transformer bank.



Figure 5-18. Three-phase transformer bank.

### **Transformer Internal Connections**

Standard single-phase distribution transformers must be modified internally to produce only 120 Vac as opposed to 120/240 Vac if they are to be used in three-phase transformer banks. Two of the possible three ways to internally connect the two secondary windings to produce only 120 Vac are shown in Figures 5-19 and 5-20. These transformers supply 120 volts only. The reason Figure 5-20 would be preferred by a power company is its similarity to connecting a standard 120/240 transformer in that the center secondary neutral bushing connection is in the same position in both cases.

#### **The Standard Three-Phase Wye–Wye Transformer Bank (208/120 Vac)**

Three single-phase transformers are connected together to form a transformer bank. The most popular three-phase transformer bank configuration (i.e., wye–wye) is shown in Figure 5-21.

#### **The Standard Three-Phase Wye–Wye Transformer Bank (480/277 Vac)**

Larger consumers require 480/277 Vac three-phase power. The three-phase transformer configuration that follows current standards for three-phase 480/277 Vac Wye–Wye is shown in Figure 5-22. Industrial consumers that have large motors, several-story buildings, many lights, and so on usually require the higher 480/277 Vac service as opposed to the lower 208/120 Vac service. (Note again that the higher-voltage system requires lower currents, smaller wires, leads to fewer losses, and so on for the same power level.)

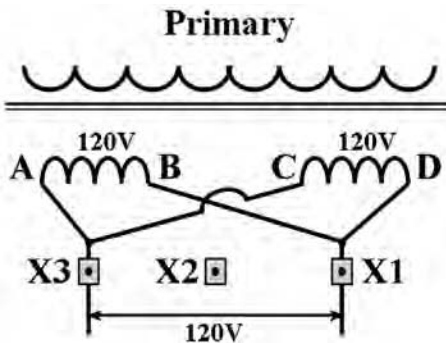

Figure 5-19. Transformer bank connection #1.

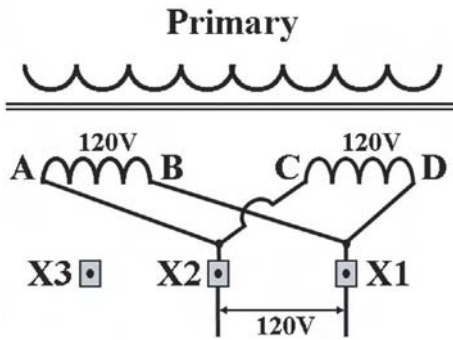

Figure 5-20. Transformer bank connection #2.

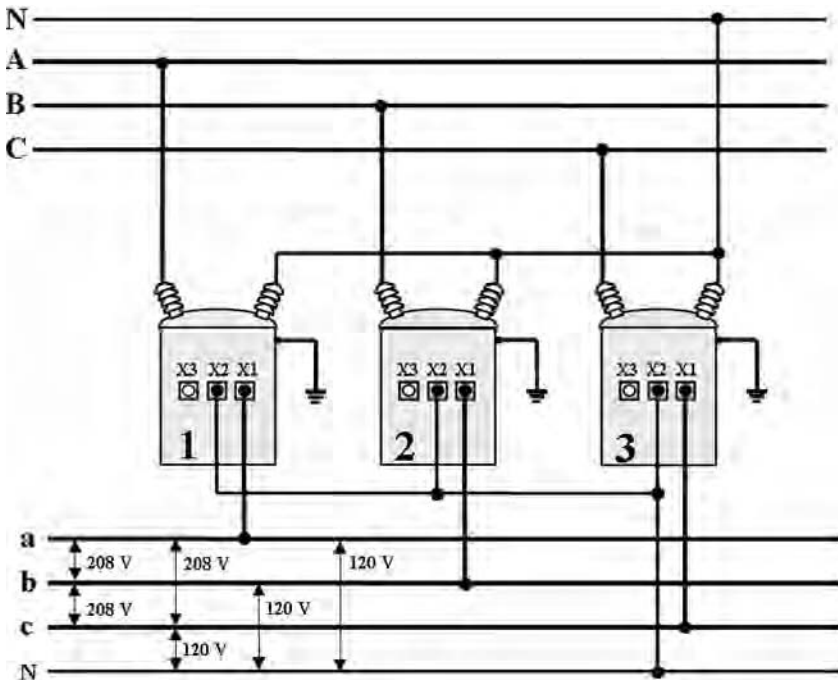

Figure 5-21. 208/120 Vac, three-phase wye-wye connection diagram. Courtesy of Alliant Energy.

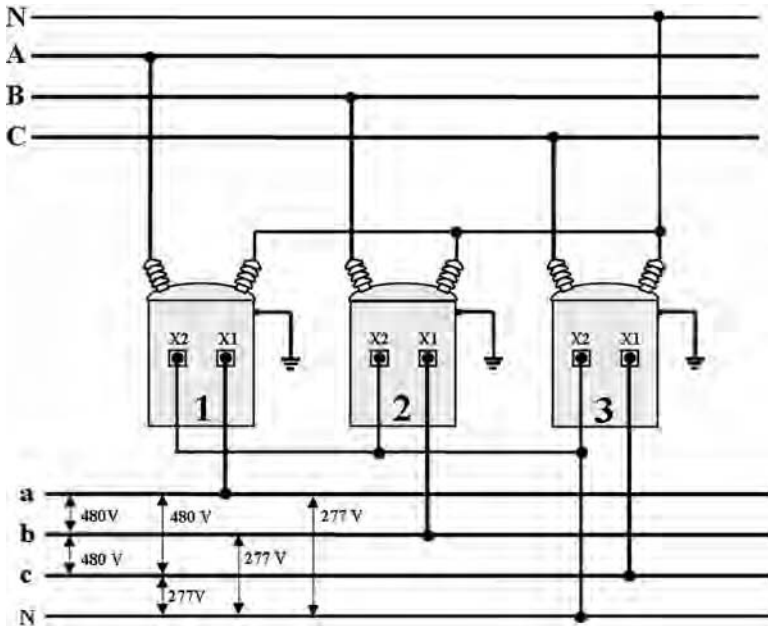

Figure 5-22. 208/120 Vac, three-phase connection diagram.

**Delta Connections**

Delta–delta, wye–delta, and delta–wye distribution transformer bank configurations are not as common as the standard wye–wye configuration and, therefore, are not discussed in this book.

**Dry Pack Transformers**

Consumers that take service at 480/277 Vac usually require *dry-pack* transformers at their facility to provide 208/120 Vac service to power standard receptacles and other basic 120 Vac necessities. Dry pack implies no insulation oil is contained in the transformer. These dry pack transformers are often located in closets or small rooms with high-voltage warning signs posted on the door. Figure 5-23 is an example of a dry pack transformer.

Most of the large motor loads (i.e., elevators) at these larger consumers operate at 480 Vac three-phase. The large arrays of lighting use 277 Vac line-to-ground single-phase power. Therefore, just the basic 120 V loads use the dry-pack transformers.





Figure 5-23. Dry pack transformer. Courtesy of Alliant Energy.

## FUSES AND CUTOUTS

The purposes of a *fuse* are to interrupt power flowing to equipment when excessive current occurs and to provide equipment damage protection due to short circuits and power faults. Fuses like that in Figure 5-24 interrupt the flow of current when the maximum continuous current rating of the fuse is exceeded. The fuse takes a very short period of time to melt open when the



Figure 5.24. Distribution fuses.

current rating is exceeded. The higher the excessive current, the faster the fuse melts.

*Fused cutouts* like that shown in Figure 5-25 are the most common protection devices in the distribution system. They are used to protect distribution transformers, underground feeds, capacitor banks, PTs, and other equipment. When blown, the fused cutout door falls open and provides a visible break in the circuit for line workers to see. The hinged door falls open and hangs downward as shown in Figure 5-26. Sometimes, the door does not fall open; it remains intact due to ice, corrosion from salt fog, or other mechanical operation infringements. Line workers on patrol for an outage can normally see the blown fuse from a distance.

Comparing fuses to circuit breakers, circuit breakers have the ability to open and close circuits repeatedly, whereas a fuse opens the circuit one time and must be replaced. Fuses are single-phase devices, whereas circuit breakers are normally gang-operated three-phase devices. Breakers can interrupt very high magnitudes of current. Breakers close into a fault and trip open again. Breakers can be controlled remotely and need periodic maintenance.

## RISER OR DIP POLE

The purpose of a riser or dip pole is to transition from overhead construction to underground construction. Some electric utilities refer to them as *dip*



Figure 5-25. Fused cutout. Courtesy of Alliant Energy.



Figure 5-26. Fuse door. Courtesy of Alliant Energy.

*poles* when the power source is overhead serving the underground and *riser poles* when the source is underground serving the overhead. Either way, they represent an overhead-to-underground transition. An example of a typical dip pole is shown in Figure 5-27.

## UNDERGROUND SERVICE

Underground construction is usually about three to five times more costly than overhead construction. Most people prefer underground construction as opposed to overhead. Underground systems are not exposed to birds, trees, wind, and lightning, and should be more reliable. However, underground systems fault due to cable, elbow, splice, dig-in, and connector failures. When underground systems fault, they usually cause significant damage (i.e., cable, elbow, or splice failure). Therefore, underground feeders are usually not automatically reclosed.



Figure 5-27. Dip pole.

## Primary Distribution Cable

Primary underground cables are one of the most important parts of any underground system. If a fault occurs on an underground cable, the feeder or fused section of line is out of service until a crew can isolate the bad section of cable and perform necessary load-transfer switching to restore power.

Most primary distribution cables like the one shown in Figure 5-28 consist of two conductors (main center conductor and *concentric neutral* conductor) with layers of insulation and semiconductive wraps. The main cen-

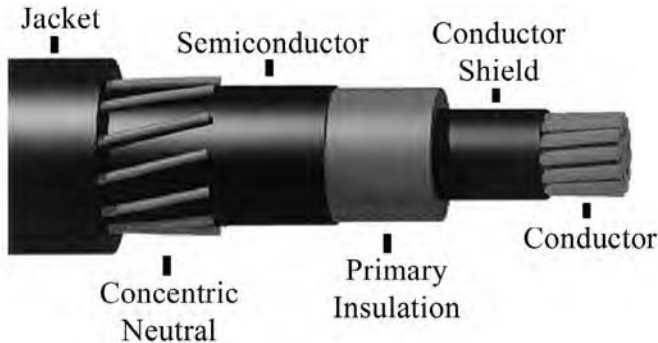

Figure 5-28. Single-conductor primary distribution cable. Courtesy of Alliant Energy.

ter conductor is composed of either copper or aluminum. The outer conductor is the concentric neutral and is usually copper. The outer cover *jacket* is made of polyethylene, polyvinyl chloride (PVC), or thermoplastic material.

The concentric neutral helps trip a circuit breaker or fuse quickly if dug into by a backhoe or other equipment. Should a backhoe operator penetrate the cable, the blade is first grounded by the concentric neutral before striking the center conductor. This allows short-circuit current to flow and trip the breaker.

Underground cables have a significant amount of capacitance. When cables are deenergized, they can maintain a dangerous voltage charge. Special safety procedures are required when working with deenergized underground cables because of the stored or trapped voltage charge that can be present.

## Load-Break Elbow

*Load-break elbows* are used to connect underground cables to transformers, switches, and other cabinet devices. As the name implies, load-break elbows are designed to connect and disconnect energized lines to equipment. One can also energize and deenergize underground cables with load-break elbows. However, safe working practices normally require personal insulated rubber protection and fiberglass tools to insure safe working conditions when installing or removing elbows. Figure 5-29 shows a line worker wearing rubber gloves removing an underground cable elbow using a fiberglass insulated tool. Figures 5-30 and 5-31 show typical load-break elbow connectors.



Figure 5-29. Load-break connections. Courtesy of Alliant Energy.



Figure 5-30. Load-break elbow.

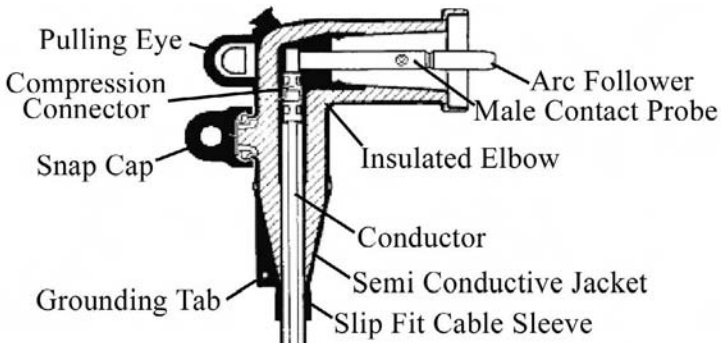

Figure 5-31. Load-break elbow components.

## Splices

Underground splices are used to connect cable ends together. They are normally used for extending cable or emergency repairs. It is preferable not to use splices. They, like anything else, add an element of exposure to failure.

Figures 5-32 and 5-33 show typical splices used in underground distribution systems. Note: all underground connections, especially elbows and splices, require special installation procedures to assure high-quality results for long-term reliable performance. Underground equipment is susceptible to water and rodent damage.

## Underground Single-Phase Standard Connection

Figure 5-34 shows a 7.2 kV, 120/240 Vac single-phase 25 kVA padmount transformer. Two high-voltage bushings are on the left and the low-voltage connectors are on the right. The two high-voltage bushings allow *daisy chain-ing* transformers in series to serve multiple residences in a loop arrangement.

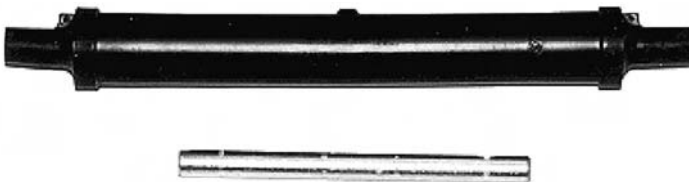

Figure 5-32. Underground long-compression splice with cover. Courtesy of Alliant Energy.

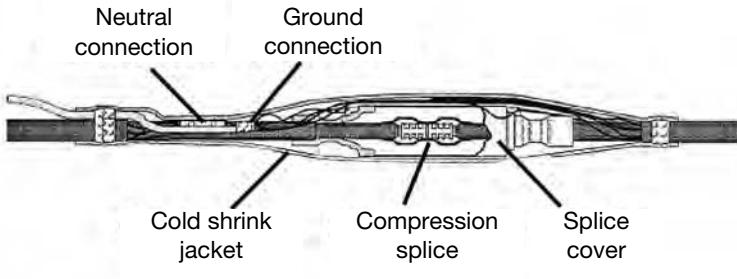

Figure 5-33. 3M primary underground splice. Courtesy of Alliant Energy.

### Underground Wye–Wye Three-Phase Standard Connections

The Figure 5-35 shows how an underground, three-phase *padmount* transformer is connected to a four-wire wye primary and a four-wire wye secondary. This is very similar to the overhead wye–wye configuration. This connection supplies 208/120 Vac three-phase service to the consumer.



Figure 5-34. Switching transformer. Courtesy of Alliant Energy.



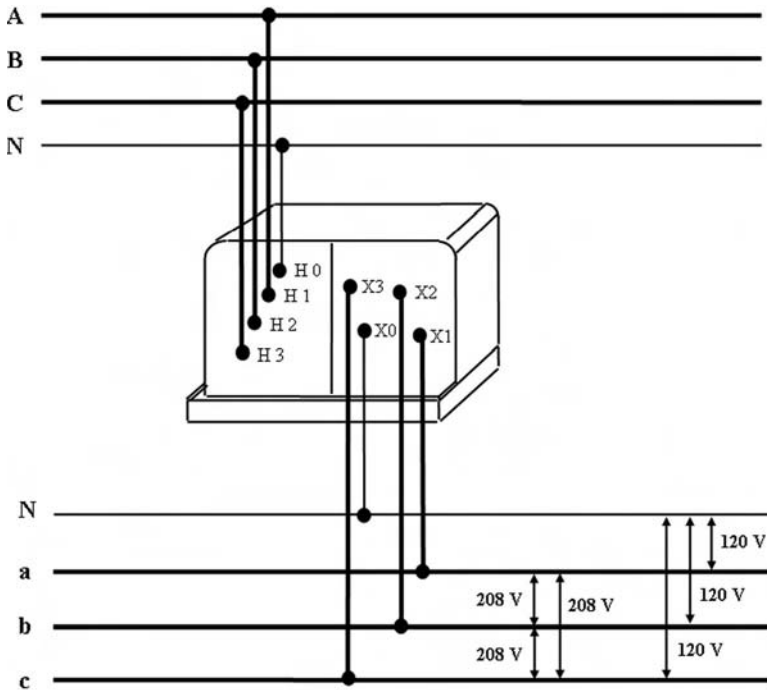

Figure 5-35. Underground wye-wye connection diagram. Courtesy of Alliant Energy.

### Single-Phase, Open Loop Underground System

A typical single-phase underground distribution system serving a small subdivision is shown in Figure 5-37. It provides reliable loop operation to several consumers. Notice the normally closed and open switches. This loop design uses pad mount transformers with incorporated switches to provide the capability of load transfer and equipment isolation during maintenance activities. Configurations like this allow a faulted section of cable to be isolated quickly and service restored while the cable is being repaired or replaced.

### Secondary Service Wire

The electric utility is responsible for the service wire between the distribution transformer and the consumers' service-entrance equipment.

Examples of secondary-service wires are shown in Figure 5-37. Secondary wires are insulated. The insulation value is much lower than for pri-

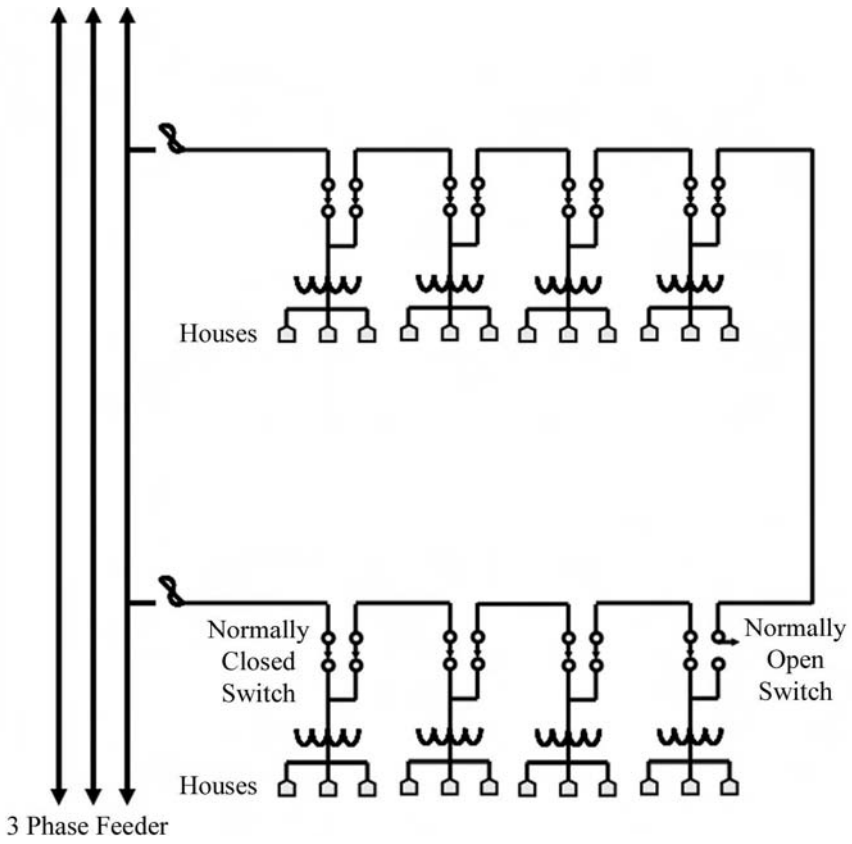

Figure 5-36. Distribution primary loop.

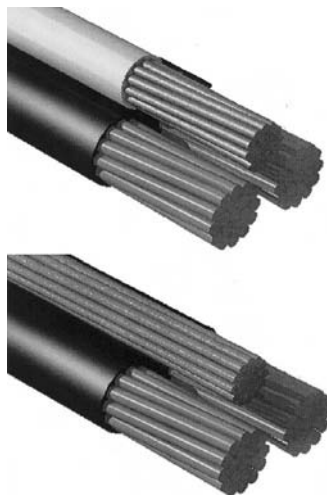

Figure 5-37. Secondary cable. Courtesy of Alliant Energy.

mary cable. Most secondary distribution wires consist of two insulated conductors and a neutral. Overhead service wires normally have the neutral conductor bare, whereas underground service wires are all insulated.

The conductor's insulation is either polyethylene or rubber coated and is usually rated at 600 Vac. The conductors are usually aluminum or copper. The neutral is usually the same size as the hot conductor.

Examples of overhead and underground *triplex* cables are pictured in Figure 5-37. (Note: *quadruplex* cables are used for three-phase services.) To reduce the clearance needed for conductors from the service pole to the service entrance, conductors may be insulated and twisted together with a neutral. For single-phase service, such as street lighting, one insulated conductor is twisted together with an uninsulated neutral; this is referred to as *duplex* cable.



---

# 6

---

## CONSUMPTION

---

### CHAPTER OBJECTIVES

- ✓ *Explain the categories of energy consumption (residential, commercial, and industrial) and their consumption characteristics*
- ✓ *Explain power system efficiency and power factor*
- ✓ *Discuss demand-side management*
- ✓ *Explain the various types of electric power metering*
- ✓ *Discuss residential service entrance equipment, panels, and branch circuit configurations*
- ✓ *Explain how to wire residential lighting, receptacles, GFCI circuit breakers, and 240 Vac circuits*
- ✓ *Explain the common problems with starting large motors and how the various types of soft-start equipment help reduce flicker*
- ✓ *Discuss industrial service-entrance equipment, equipment wiring, emergency generators, and uninterruptible power systems (UPS)*

## ELECTRICAL ENERGY CONSUMPTION

Electrical energy consumption is the electrical energy use by all the various loads on the power system. Consumption also includes the energy used to transport and deliver the energy. For example, the losses due to heating conductors in power lines, transformers, and so on is considered consumption.

Electricity is consumed and measured in several different ways depending on whether the load is residential, commercial, or industrial, and whether the load is resistive, inductive, or capacitive. Electric utilities consume electricity just to produce and transport it to consumers. In all cases, electrical energy production and consumption is measured and accounted for. The electrical energy produced must equal the electrical energy consumed. This chapter discusses the consumption side of electric power systems. It also explores the types of loads, their associated power requirements, and how system efficiency is measured and maintained.

In *residential* electric consumption, the larger users of electrical energy are items such as air conditioning units, refrigerators, stoves, space heating, electric water heaters, clothes dryers, and, to a lesser degree, lighting, radios, and TVs. Typically, all other home appliances and home office equipment use less energy and, therefore, account for a small percentage of total residential consumption. Residential consumption has steadily grown over the years and it appears that this trend is continuing. Residential energy consumption is measured in kilowatt-hours (kWh).

*Commercial* electric consumption is also steadily growing. Commercial loads include mercantile and service, office operations, warehousing and storage, education, public assembly, lodging, health care, and food sales and services. Commercial consumption includes larger-scale lighting, heating, air conditioning, kitchen apparatus, and motor loads such as elevators and large clothes handling equipment. Typically, special metering is used to *record peak demand* (in kilowatts) along with energy consumption in kWh.

*Industrial* electric consumption appears to be steady. Industrial loads usually involve large motors, heavy duty machinery, high-volume air conditioning systems, and so on, for which special metering equipment is used such as *power factor, demand, and energy*. Normally the consumption is great enough to use CTs (current transformers) and PTs (potential transformers) to scale down the electrical quantities for standard metering equipment.

Very large electrical energy consumers (i.e., military bases, oil refineries, mining industry, etc.) often use *primary metering* facilities to measure their consumption. These large consumers normally have their own subtransmission and or primary distribution facilities including substations, lines, and electrical protection equipment.

## Consumption Characteristics

It is helpful to understand how the three types of load (i.e., resistors, inductors, and capacitors) work together in power systems because their relationships influence system losses, revenues, and reliability. This section explains how these loads interact and how their interaction improves the overall performance of electrical power system operations.

### Basic ac Circuits

The three basic types of ac circuits are resistive, inductive, and capacitive. These circuit types with ac power sources are shown in Figure 6-1.

Depending on the type of load connected to an ac voltage source, a time difference between the voltage and current exists. This time difference is also referred to as the *phase angle* (lead or lag) between the voltage and current. The phase angle is usually measured in degrees since there are 360 degrees in one complete cycle.

### Phase Angle

In ac power systems, the voltage and current have the same frequency but have different amplitudes and phase angles. The phase angle between voltage and current is shown in the Figure 6-2. Note: in this figure the current wave crosses the horizontal axis later than the voltage wave and, therefore, is said to lag the voltage. Therefore, this device must be *inductive*.

Note, too, that the amplitude of current at the same time that voltage peaked is less than the peak current. This difference in current amplitude has great significance when it comes to minimizing power losses and maximizing overall power system *efficiency*. In other words, *reducing the phase angle reduces the amount of current needed to get the same amount of work done in the loads*. For example, adding capacitors to motors reduces the total current required from the generation source. Reducing the total current

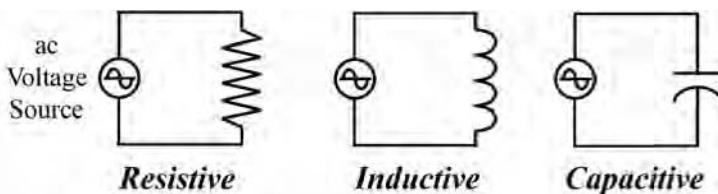

Figure 6-1. Types of circuits.

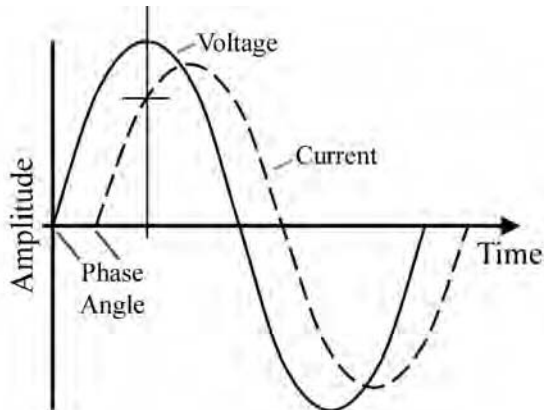

Figure 6-2. Phase angle between voltage and current.

reduces system losses and improves the overall efficiency of the power system.

### ***Phase Angle Comparisons between Load Types***

The phase angle between the voltage and current is different for each basic load type. Figure 6-3 shows the three load-type phase angles.

### ***Combining Load Types***

When both inductive loads and capacitor loads are connected together, their phase angles oppose each other. Figure 6-4 shows this concept. Part A shows how the lagging inductive phase angle added to the leading capacitive phase angle can equal the phase angle of resistive loads. The phase angle does not have to cancel entirely; the net result can be either inductive lagging or capacitive leading. Part B shows two ways capacitors and inductors can be connected together to make their phase angles combine. Part C shows the equivalent resistive circuit when combining these two electrical components at full cancellation.

## **POWER SYSTEM EFFICIENCY**

The *efficiency* of a power system is maximized when the total combined load is purely resistive. Therefore, when the total load on the system approaches purely resistive, the total current requirements and losses are minimum. The



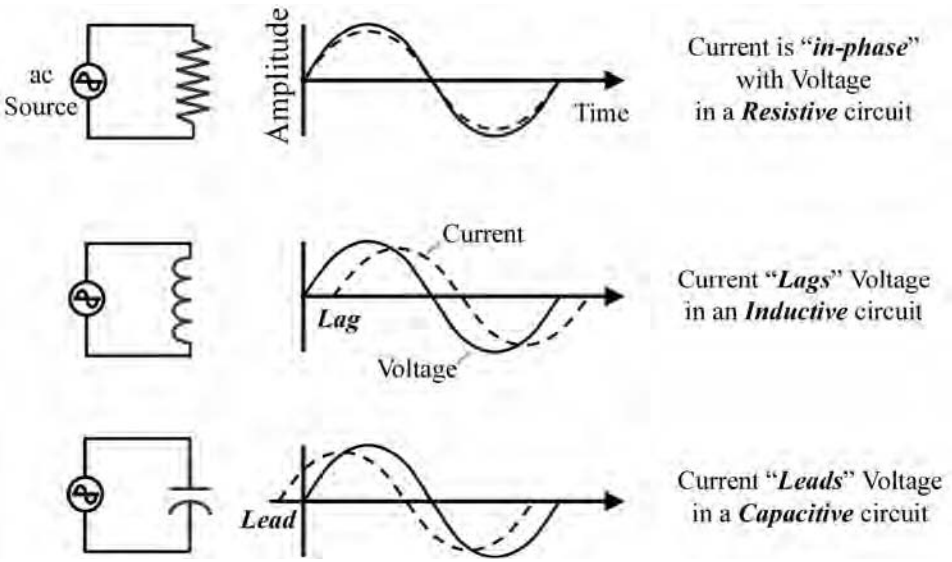
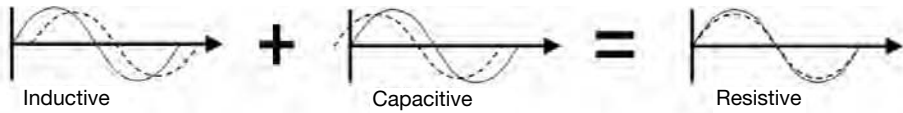
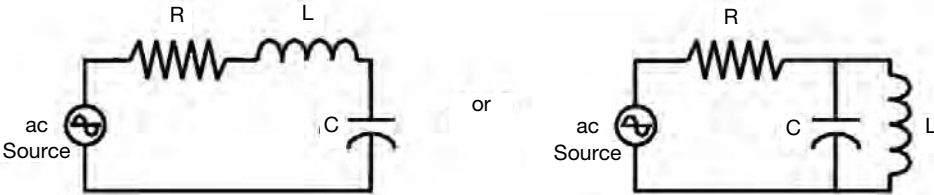

Figure 6-3. Voltage and current relationships.

**PART A**



**PART B**



**PART C**

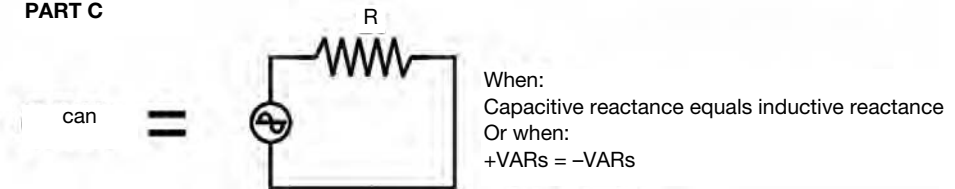

Figure 6-4. Equivalent circuits.

total power that has to be produced is minimized when the load is purely resistive. The total power becomes “real” power (i.e., watt power) only.

When the system efficiency is maximized (i.e., minimum power required to serve all loads), two significant benefits are realized:

1. Power losses are minimized
2. Extra capacity is made available in the transmission lines, distribution lines, and substation equipment because this equipment is rated on the amount of current carrying capability. If the current flow is less, the equipment has more capacity available to serve additional load.

One way to measure the power system efficiency is by calculating the power factor.

## POWER FACTOR

The efficiency of a power system can be viewed as: how much total power (i.e., “real” power plus “reactive” power) is required to get the “real” work done. The *power factor* is a calculation that is based on the ratio between real power and total power, as shown below:

$$\text{Power Factor} = \frac{\text{Real Power}}{\text{Total Power}} \times 100\%$$

Typically, power factors above 95% are considered “good” (i.e., high) and power factors below 90% are considered “poor” (i.e., low). Some motors, for example, operate in the low 80% to 85% power factor range and the addition of capacitors would improve the overall efficiency of the power supply to the motor.

For example, suppose you were trying to cross a river from point “A” to point “B” as shown in Figure 6-5. The shortest path requiring the least amount of energy would be to swim in a straight line, as shown on the left. However, suppose water is flowing downward, causing you to swim a little upward toward point “C” in order to arrive at point “B.” The extra energy exerted from “C” to “B” would be considered wasteful. In electrical circuits, this wasteful opposing energy is called “reactive energy.”

## Optional Supplementary Reading

Refer to Appendix B for a graphical analysis of the power factor.

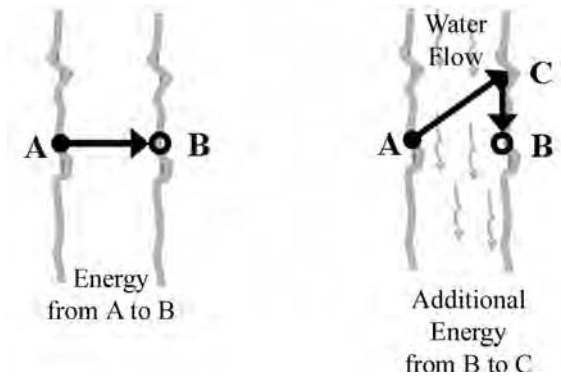

Figure 6-5. Power factor.

## SUPPLY AND DEMAND

Let us put the power system into proper perspective: first voltage, then load, then current, then power, and then energy. During use, system losses occur, requiring increased supply to achieve a balance between generation (supply) and consumption (demand). During this process, the electric utilities try to maintain good regulated voltage for all consumption types and levels. The consumers draw the current and use the power and energy from the system. The consumers and system losses dictate the demand. The power producers must supply this demand through transmission and distribution systems to the consumers.

Electric power systems operate in real time. As load increases, generation must increase to supply the demand with good voltage and frequency. Otherwise, voltage would collapse, frequency would drop, consumer lights would dim, and motors would overheat because load equipment is designed for a given voltage and frequency.

## DEMAND-SIDE MANAGEMENT

Since the amount of load (i.e., demand) determines the amount of generation (i.e., supply), the best way to minimize the need for additional supply is to reduce or control demand. Therefore, demand side management programs are being implemented everywhere to manage load growth and achieve economic stability. *Demand-side management* (DSM) programs are designed to provide assistance to consumers in order to help reduce their en-

ergy demand and control their energy cost while delaying the construction of generation, transmission and distribution facilities. These DSM programs provide assistance by conducting energy audits, controlling consumer equipment, or providing economic incentives. These programs are designed for residential and business consumers.

The kinds of incentives provided depend on the consumer type as described below.

## **Residential**

The demand-side management programs that pertain primarily to residential and small business loads include the following:

- Lighting (i.e., rebate coupons, discounts for high-efficiency lightbulbs, efficient lighting designs, and other energy-reduction incentives)
- High-efficiency washing machines, clothes dryers, and refrigerators
- Home energy audits
- Insulation upgrades
- Appliance management
- Control some equipment to only operate during off-peak periods (water heaters, pool pumps, irrigation pumps, etc.)

## **Commercial**

The demand-side management programs that involve commercial consumers are geared more toward overall operations efficiency, for example:

- The efficient design of buildings and remodeling or renovation activities using more energy efficient products and technologies without increasing project costs. This would include lighting, heating, air conditioning, motor upgrades, variable-speed drives, and more efficient electrical equipment.
- Replacement incentives to remove older, lower-efficiency equipment.
- Energy consumption analysis programs to encourage better operational methods within a business or organization.

## **Industrial**

The demand-side management programs for industrial consumers focus on energy initiatives, for example:

- Renewable energy resources incentive programs to increase the utilization of wind power, solar energy, fuel cells, and so on to generate electricity for their own facility.
- Incorporation of online energy-load profiles to be used to strategize improvement of load patterns toward energy conservation.
- Energy consumption surveys or studies to provide recommendations for load curtailment.

There are other demand-side incentives that are available to help reduce electrical energy consumption such as exterior or interior shading, awnings, wall glazing, heat reflectors, and automatic control devices.

There is a concerted effort being made in the electrical industry to focus on ways to make electric energy consumption more efficient, less demanding, and less dependent on foreign energy resources. Energy production, transmission, and distribution costs, especially operational losses, expansion, and fuel dependency, originate with consumption. Consumption control through demand-side management programs is the best way to postpone new generation projects, maintain or lower electric utility costs, and conserve energy.

## METERING

Electric metering is the process of direct measurement of energy consumption. The electric quantities being measured depend on the consumer type and level of consumption. Residential consumers are metered for *energy* consumption in kilowatt-hours (kWh). Small commercial and industrial might have a *demand* meter as part of their metering package. Large industrial consumers might have energy (kWh), demand (peak kW), and *power factor* metering (%PF). The largest consumers of electricity might receive their power at distribution primary, subtransmission, or transmission voltage levels so that *primary metering* is required.

### Residential Metering

The most common type of electric meter is the kilowatt-hour meter, like those shown in Figures 6-6 and 6-7. These meters measure electrical energy. Energy is the product of power times time. Note, since only watts are measured, total power is not measured (i.e., total power would include reactive power in VARs). Therefore, the units measured are *watt-hours*. For scaling

purposes, the *kilowatt-hour (kWh)* is used as the standard unit for measuring electrical energy for residential customers.

The older dial-type kWh meters measure the actual energy flow in the three conductor service wires from the power utility’s distribution transformer. The current flowing on both legs (i.e., each 120 Vac conductor) and the voltage between the two legs provide the necessary information to record residential energy consumption. Residential load connected to 240 Vac is also measured because its current also flows through the two hot-leg service conductors.

The dials turn in ratios of 10:1. In other words, the dial on the right makes 10 turns before the next dial on its left moves one turn, and so on. The difference between dial readings is the energy consumption for that period. The electronic or solid-state meters record additional information such as time of use and, in most cases, can remotely communicate information to other locations through telephone lines, radio signals, power lines, or to small hand-held recording units.

### Demand Metering

Small commercial and light industrial loads might have *demand* meters incorporated in their electrical metering equipment. The customer is charged for the highest sustained 15 minute sliding-peak usage within a billing period. This type of metering is called demand metering. Some clock-type ener-

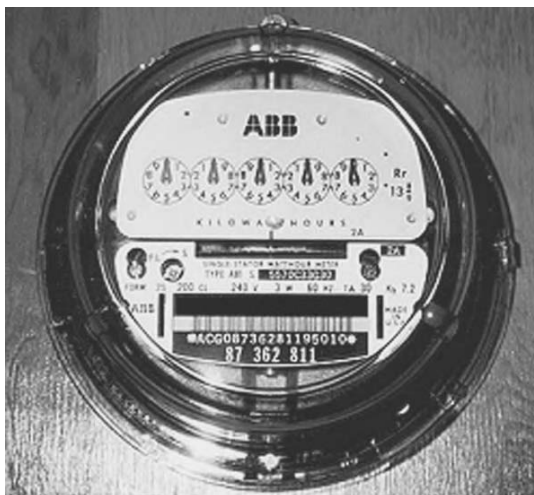

Figure 6-6. Electromechanical kWh meter.



Figure 6-7. Solid-state kWh meter.

gy meters have a *sweep demand arm*, which shows the maximum 15 minute demand for that billing cycle. Figure 6-8 shows the demand needle and scale. Figure 6-9 shows a traditional clock-type demand and energy meter. Meter readers must manually reset the demand meter’s sweep arm at each billing cycle. There are electronic, solid-state versions of demand metering also. Again, some electronic meters electronically communicate this information to the electric utility.

### Time-of-Use Meters

A variation on demand metering is *time-of-use* (TOU) metering. Whereas demand meters measure the peak demand for each billing cycle, TOU meters

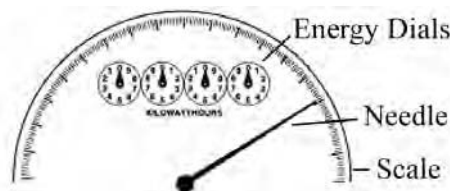

Figure 6-8. Demand needle and scale. Courtesy of Alliant Energy.

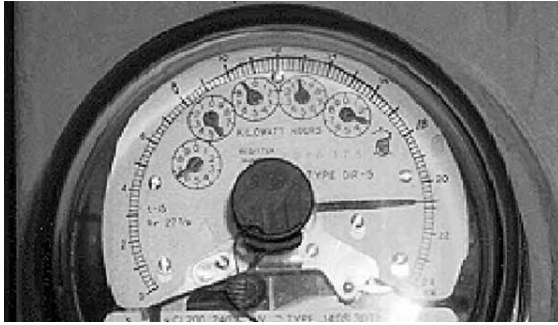

Figure 6-9. Demand meter. Courtesy of Alliant Energy.

record demand and energy consumption during the different parts of the day. TOU metering allows the utility to charge different rates for different parts of the day. For example, during the part of the day when energy consumption is highest with maximum generation online (peak periods), TOU rates are higher than at off-peak times. During the part of the day when energy consumption is lowest (off peak), TOU rates are much lower. These variable rates provide incentives to discourage consumption during peak hours and encourage consumption during off-peak hours. These units are almost always electronic, solid-state meters with communications capabilities.

## Reactive Meters

A watt-hour meter is neither designed nor intended to measure reactive power. However, by shifting the phase angle of the load CT (current transformer), a second watt-hour meter can be connected to this phase-shifted load that can measure reactive energy consumption. The phase is usually shifted with a capacitor–resistor network in single-phase systems, and with a phase-shifting transformer in three-phase systems. The phase-shifting device helps measure the circuit’s reactive power in *kiloVAR-hours (kVAR)*, or in units of 1,000 VAR-hours. When connected this way, the second kVAR-hour meter is called a *reactive meter*. The electric utility can calculate the average power factor based on kWh and kVARh information. Some utilities employ direct reading power factor meters with which peak power factor information is also provided.

## Primary Metering

Some customers have very large loads for their operation and require service at the primary distribution voltage. Special primary voltage metering or



metering at voltages over 600 V is required. Metering personnel install what is known as *primary metering* equipment when it is not practical to do the metering at secondary voltage levels. Primary metering equipment includes high-accuracy potential transformers (i.e., metering class PTs) and high-accuracy current transformers (i.e., metering class CTs). Special structures, equipment cabinets, or equipment racks are required with this type of metering installation.

There are many possible ways to build primary metering equipment housings depending on the type of application. For example, primary metering equipment might apply to underground (Figure 6-10), overhead (Figure 6-11), substation, or industrial installations.

## PERFORMANCE-BASED RATES

Some regulated utilities (i.e., distribution companies) are being faced with performance-based rates. That is, the Public Service Commission or other regulatory agency has established certain performance criteria relating to customer service reliability and a utility's reliability performance is taken into consideration when rate increases are requested. If the utility meets or exceeds set criteria, it is usually allowed to collect a "bonus" on the base



Figure 6-10. Underground primary metering. Courtesy of Alliant Energy.



Figure 6-11. Overhead primary metering.

rate. On the other hand, if the utility fails to meet the established criteria, the utility may be penalized with a lower rate of return.

Some of the performance-based rate indices include:

- *SAIFI*, which stands for system average interruption frequency index
- *SAMII*, which stands for system average momentary interruption index
- *SAIDI*, which stands for system average interruption duration index

All of these and other measurements focus on reliable service to the customer. These indexes were originally manually derived based on daily outage reports and are now supplied by the system control center's computers.

Reliability and stability of the overall power grid system that involves generation and transmission is discussed later in Chapter 8, Integrated Power Systems.

## SERVICE-ENTRANCE EQUIPMENT

The electric utility connects their service wires to the consumer's service-entrance equipment. The National Electric Code (NEC) has very specific rules, regulations, and requirements on how service-entrance equipment must be designed, installed, connected, and/or inspected. This section discusses the basic equipment designs, demand-side connection, and special load characteristics considerations used for residential, commercial, and industrial consumers.

### Residential Service-Entrance Equipment

Actual service-entrance equipment can vary from manufacturer to manufacturer, however the basic designs and concepts are standard. The concept is to provide a standard and practical means of connecting the electric utility's 120/240 Vac single-phase service having two hot legs and one neutral wire to residential loads throughout the premises.

The standard *distribution service panel* is usually designed to encourage the balancing of the 120 V hot legs with connected loads. These designs usually make it convenient to connect 240 volt loads with one combo circuit breaker. Since each consecutive circuit breaker space connects to opposite hot legs, usually any two adjacent breaker spaces conveniently connect both hot legs for 240 Vac operation. Therefore, a 240 Vac connection is accomplished by connecting two 120 V breakers in adjacent spaces. Then a plastic *bridge clip* connects the two 120 V breakers together, causing both breakers to trip if a problem occurs on either breaker.

A typical 120/240 Vac panel is shown in Figure 6-12. Note the meter socket. Figure 6-13 shows the same residential panel with the outside cover removed, exposing the meter socket and breaker spaces. Figure 6-14 shows the panel with the breaker space cover removed. This panel is ready for wiring. Figure 6-14 shows the individual breaker position spaces (without the breakers). Note that the center of the lower portion has the metal tabs alternating left and right. This allows vertically adjacent circuit breakers to connect to opposing legs for 240 V service.

### Service Entrance Panel

The drawing in Figure 6-15 shows how the two hot legs and neutral are connected inside a typical distribution panel. The primary neutral is connected to the neutral bus bar. The neutral bus bar is grounded to the building's "*ufer ground*." The "*ufer*" ground gets its name from the fact that the con-



Figure 6-12. Basic panel.



Figure 6-13. Meter cover removed.

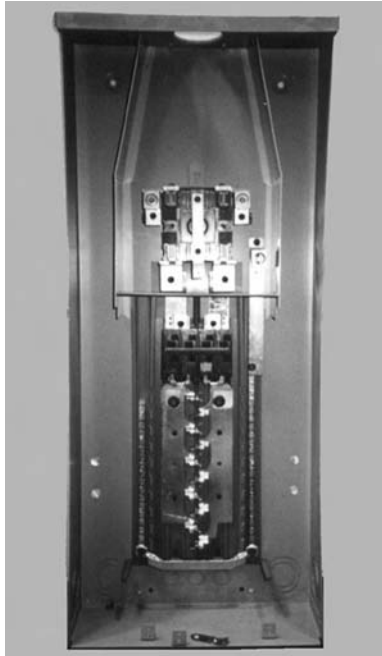

Figure 6-14. Breaker cover removed.

sumer provides this ground connection when the facility is built. Therefore, a consistent ground connection between the electric utility and the consumer is provided. This is a NEC requirement. This common ground connection improves voltage stability, protection equipment effectiveness, and safety. It is most effective with wye-connected primary distribution systems as opposed to delta-connected systems.

The two hot legs of the service-entrance conductors are first connected to the *main breaker*. Notice how adjacent circuit breakers connect to opposite legs of the 120/240 Vac service wires. This arrangement encourages the balancing of load. Further, connections to two adjacent breakers provide the 240 Vac source. Note that the two breakers involved in providing 240 V service have a plastic clip across their levers so that if one leg trips, both legs trip.

### **Light Switch**

Figure 6-16 shows how a standard light-switch circuit is configured. The NEC color code standard is stated. Note how the wires can be extended to connect additional loads for a single breaker. The green ground wire is used to connect the light fixture metal to ground. Also note how the green ground

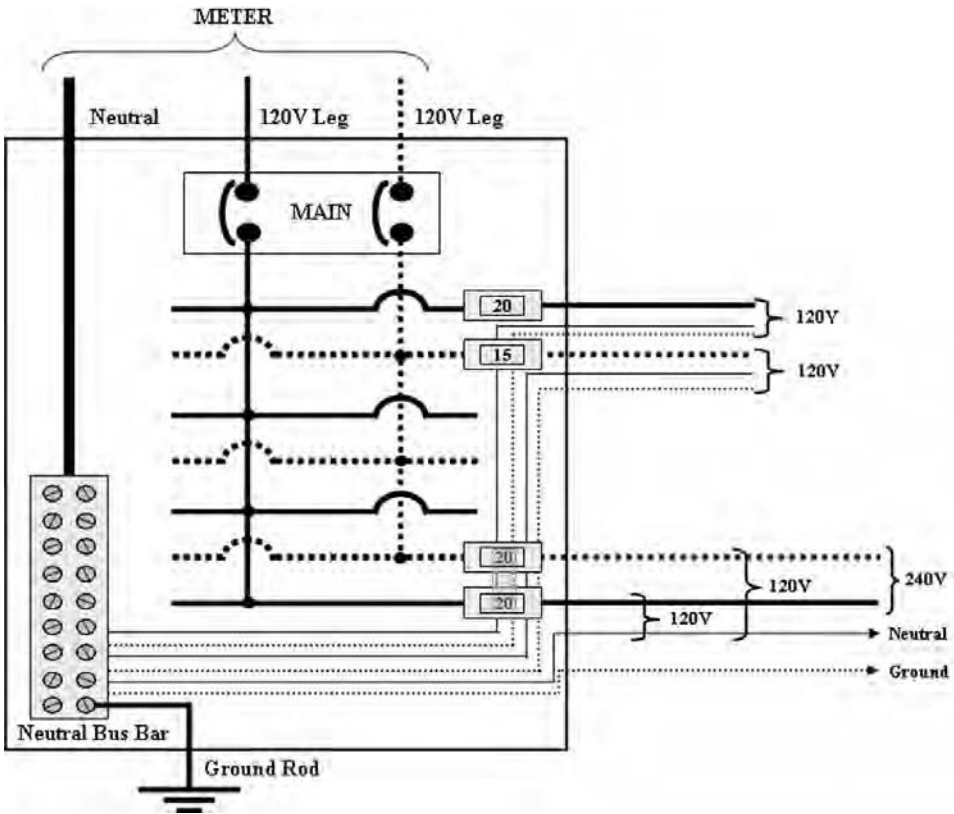

Figure 6-15. Electrical panel—residential.

wire and the white neutral wire eventually connect to the same location. The reason for connecting the two wires together is to provide an appliance ground connection should a hot wire fray and short out to the metal appliance. The exposed hot wire shorts out with the metal appliance ground and trips the panel breaker, thus removing a potentially dangerous situation.

### Receptacle

Figure 6-17 shows the basic connections of a standard three-conductor receptacle. Note that the hot wire is connected to the short slot in the receptacle and the neutral wire is connected to the long slot. That too is a NEC requirement. The grounding wire is connected to the round holes in the receptacle, the screw hole that holds down the cover plate, and the bracket that mounts the receptacle to the junction box. Therefore, the cover plate

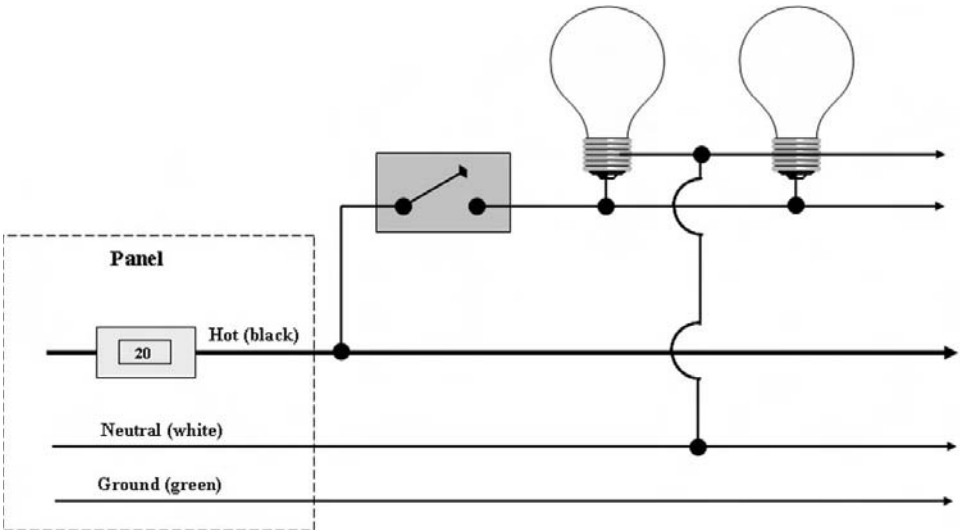

Figure 6-16. Light circuit.

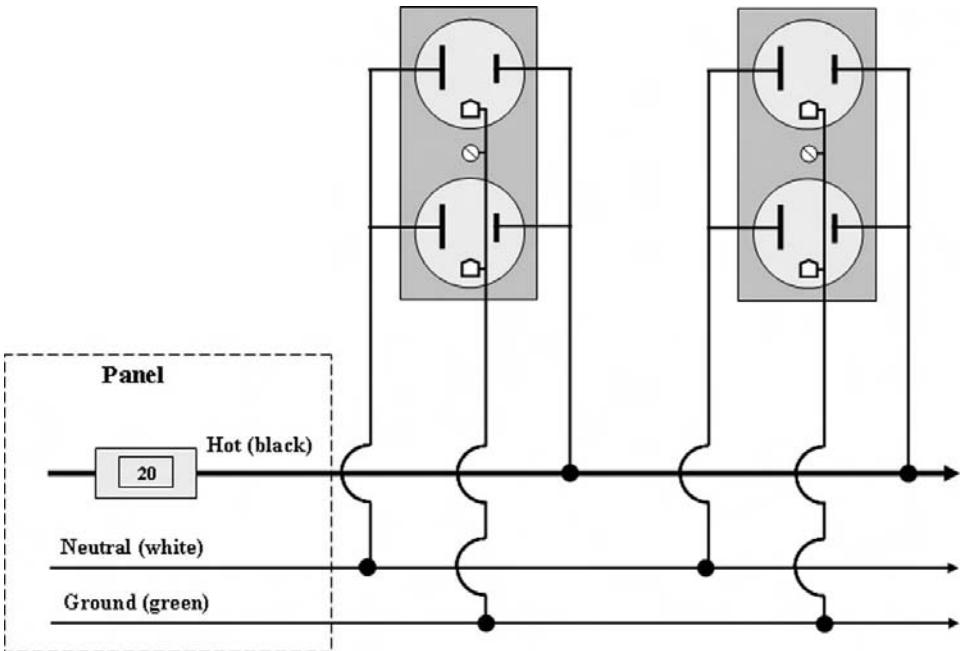

Figure 6-17. Receptacle circuit.

screw is a direct connection to ground. *This screw connection is very important for safely grounding devices that use adapters for connecting older-style plugs.*

### Ground Fault Circuit Interrupter Receptacles

Figure 6-18 shows the basic connections standard for a *ground fault circuit interrupter* (GFCI) receptacle.

The purpose of the GFCI is to interrupt current flow should the amount of current flowing out on the hot leg (black) not match the current returning on the neutral (white). The difference only has to be in the order of 5 milliamps to trip the breaker.

The GFCI is an essential safety device. The NEC requires GFCI protection to be provided in all bathroom, kitchen (receptacles within 3 feet of the sink), outdoor, and garage receptacles. Most GFCI receptacles offer an extra set of screws for load connections to additional receptacles to be protected by the same GFCI.

An amendment to the National Electric Code in 2000 required that after 2003, all “bedroom” circuits in a residential installation be served from an *arc fault interrupter* (AFI) type circuit breaker located in the service panel. This requirement came about because of the concern over the number of fires caused by electric blankets and other warming devices that have deteriorated insulation and arcing thermostats. Most of the time, the deteriorated insula-

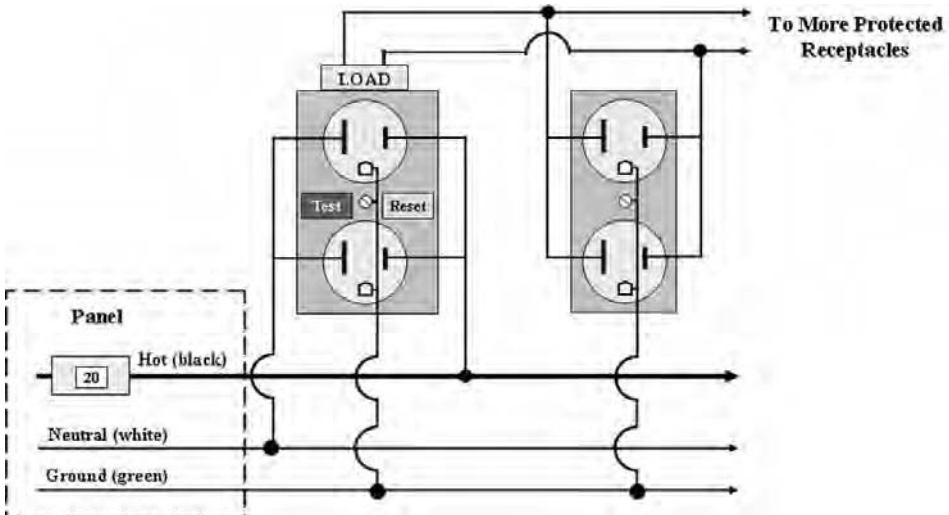

Figure 6-18. GFCI circuit.



tion allowed arcing and sparking to take place, but there was not enough current to trip a standard circuit breaker. The AFI detects the *electrical noise* generated by arcing and sparking, and trips open the circuit breaker. (Note: to avoid arguments, it is normally assumed that if a room has a closet, or is capable of having a closet, it should be considered a bedroom for code compliance, and the outlets in the room should be served through AFI devices.)

### 240 Volt Loads

Figure 6-19 shows the basic connection wiring of standard 240 volt loads (i.e., clothes dryers, stoves, and water heaters):

Note that the two 120 V breakers are bridged together with a plastic cap so that both breakers trip if either one trips. In many cases, a single molded case is used to house the 240 V breaker mechanism. In this case, there are two circuit breakers inside the case, but only one control switch handle.

The neutral (white) wire is brought into the 240 V appliance to be used for any 120 V loads such as lights, clocks, and timers. The ground wire (green) is connected to the metal appliance. The green ground wire will cause the 240 V panel breaker to trip should either hot wire fray and short circuit to the metal appliance.

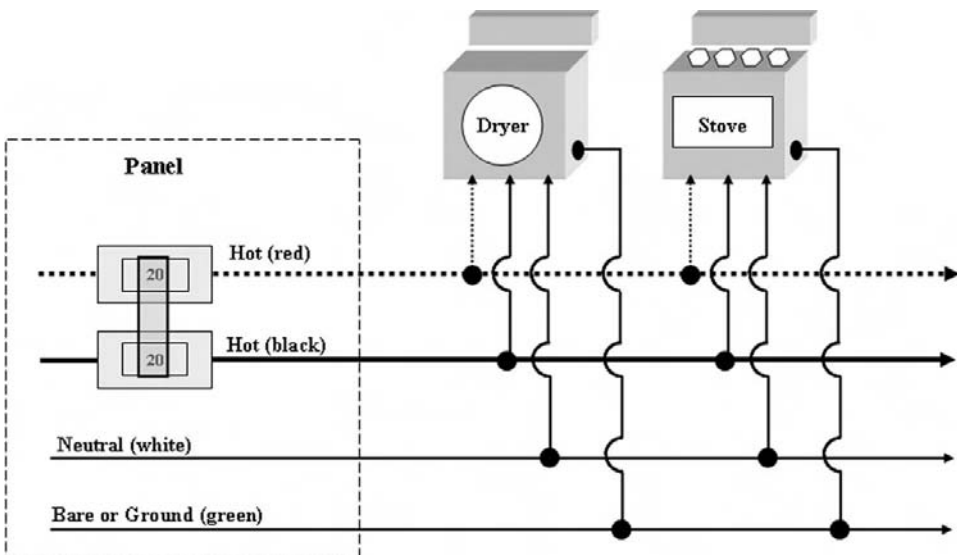

Figure 6-19. 240 volt circuit.

## Commercial and Industrial Service-Entrance Equipment

Commercial and industrial service-entrance equipment like that shown in Figure 6-20 normally consists of metering equipment (including CTs), a main circuit breaker, disconnect switch, several feeder breakers, and, sometimes, power-factor-correction capacitors, emergency generator with transfer switch, and an uninterruptible power supply (UPS) system. Some large industrial operations have very large motors requiring soft-start (sometimes called reduced voltage start) equipment to reduce inrush current to motors when starting.

### ***Power Factor Correction***

Low power factor loads such as motors, transformers, and some electronic nonlinear loads require reactive energy or “VARs” from the utility to operate properly. Excessive reactive energy demand should be reduced or minimized with capacitors to improve voltage support, reduce losses, lower power bills (in some cases), and improve overall power efficiency (on both sides of the meter).

The power factor is the ratio of real power (i.e., watts) to the total power (i.e., magnitude of the watts plus VARs). The reactive portion of the total



Figure 6-20. Industrial panel. Source: Photovault.

power can be reduced or eliminated with the application of shunt capacitors. The consumer's power factor information is used to calculate the capacitor requirements.

An easy way to comprehend the meaning of "reactive" energy requirements is to consider a motor that requires magnetic fields to operate. A motor is made up of coils of wires and a large metal rotor that spins to produce mechanical work. The current passing through the wires produces the magnetic fields required to make the motor spin. The energy used to create the magnetic fields just to spin the rotor is "reactive" energy and this reactive energy does not provide useful work by itself. The "real" component of total energy produces the useful work. Installing capacitors to counteract the motor's need for reactive power reduces, minimizes, or eliminates the reactive component of total power from the energy source. The installation of shunt capacitors can help supply the reactive requirements of the motor (i.e., inductive loads). The improved power factor from the installation of shunt capacitors is measured by the power factor metering equipment. The consumer is then charged less if their utility charges for a poor (low) power factor.

To correct low power factors, the customer and/or the utility install the capacitors. When the utility installs the capacitors, the consumer still pays a utility-reactive energy fee because the reactive power still flows through the meter. When the consumer installs the capacitors on their side of the meter, they no longer pay the extra utility fees. Note that not all utilities charge for low power factors.

### ***Overcorrecting the Power Factor with Capacitors***

Overcorrecting power factors with excessive capacitance increases the total current flowing on the lines. When the consumer overcorrects, the extra reactive power flows through the metering equipment and out to adjacent consumers' inductive loads.

In some cases, the consumer supplying the extra capacitance receives a credit from the utility for excessive reactive power going into the utility system. This extra reactive power is actually used by adjacent consumers. Therefore, the utility does not have to install as many system capacitors. As a result, the consumer might get a credit on their power bill. However, too much overcorrection can cause high voltage conditions and power quality issues that can weaken insulation, shorten equipment life, and cause other system problems.

Capacitor banks can be switched on or off based on load requirements, time of day, voltage level, or other appropriate condition to match the reac-

tive power demand of the load. The application of switched capacitors further improves power system and load performance.

### ***Location of Power Factor Correction Capacitors***

Typically, utilities do not require that power factor correction capacitors be located on the demand side of the meter. However, the closer the capacitors are installed to the load, the more beneficial the results. For instance, the capacitor bank can be located on the demand side of the meter and the reactive metering will register a good power factor to the utility, or the capacitor bank can be located adjacent to the load, reducing the current flow in the consumer's system. The utility is only interested in the customer's power factor at the meter. However, the customer benefits from putting the capacitors as close to the load as possible to minimize losses in the building wiring system and improve terminal voltage at the load.

### ***Motor Starting Techniques***

When large motors are started, noticeable *voltage dips* or *flicker* can occur on the consumers wiring system, the utility's system, or both. Depending on the voltage sensitivity of other connected loads, these voltage dips can be unnoticeable, annoying, or harmful to the equipment. For example, lightbulbs can dim and be annoying to office personnel; however, voltage dips can cause other motor loads to slow down, overheat, and possibly fail. Reduced motor starting equipment is often used to minimize voltage dips and flicker.

The iron and copper wires in large motors need to become magnetized before running at full speed. The inrush current required to start the motor to create the necessary magnetic fields can be as high as 7–11 times the full load current of the motor. Therefore, when large motors start, they often cause low-voltage conditions from voltage drop on the conductors from high-current flows. Utilities normally adopt guidelines or policies for starting large motors. When starting a motor exceeds the utility requirement for *voltage dip* or *flicker* (usually set around 3–7%), then special motor starting techniques are usually required.

There are several methods for reducing voltage dip and flicker. Reduced voltage motor starting equipment (i.e., *soft starting*), such as capacitors, transformers, special winding connections, and other control devices, are commonly used in motor circuitry to reduce the inrush current requirements of large motors during start-up conditions.

The three most common means of providing soft starting or reduced voltage starters on large motors are the following:

1. **Resistance** is temporarily placed in series with the motor starter breaker contacts or *contactor* to cause reduced current to flow into the motor when started. This approach can reduce the inrush current to less than five times full load current. Once the motor comes up to full speed, the resistors are shorted out, leaving solid conductors serving the motor power requirements.
2. **Wye–delta** connection changeover in the motor windings is another very effective way to reduce inrush current. The motor windings are first connected in wye, where the applied voltage is only line to ground; then the motor windings are connected in delta for full voltage and output power.
3. **Auto-transformers** are sometimes used to apply a reduced voltage to the terminals when started and then switched out to full voltage after the motor reaches full speed. This scheme can be used with motors that do not have external access to the internal windings.

### ***Emergency Stand-by Generators***

Emergency power transfer systems are commonly used to provide local emergency power upon loss of utility power. Upon loss of utility power, the generator, like that shown in Figure 6-21, is immediately started and allowed to come up to speed and warm up before the transfer switch connects the load. Potential transformers (PTs) are used in the transfer switch to sense when the utility power is on and off. These time delays are usually short, approximately 15 seconds to load pickup.

Some consumer emergency generators are used by the utility for on-line peaking generation. These generators parallel the utility power system and incorporate special protective relaying schemes to synchronize with the utility. Synchronization requires a proper match among frequency, voltage, phase angle, and rotation before the consumer's emergency generator can be connected to the utility power system.

### ***UPS Systems***

*Uninterruptible power supply* (UPS) systems are typically found in facilities such as police stations, hospitals, and control centers. Figure 6-22 is a block diagram of a typical emergency power generator system with a UPS. Notice that utility power feeds all load panels including the main, emergency, and UPS panels. Upon loss of utility power, the generator starts immediately. Once the generator is up to speed and able to carry load, the transfer switch operates and connects the generator to the emergency load panel. Note that

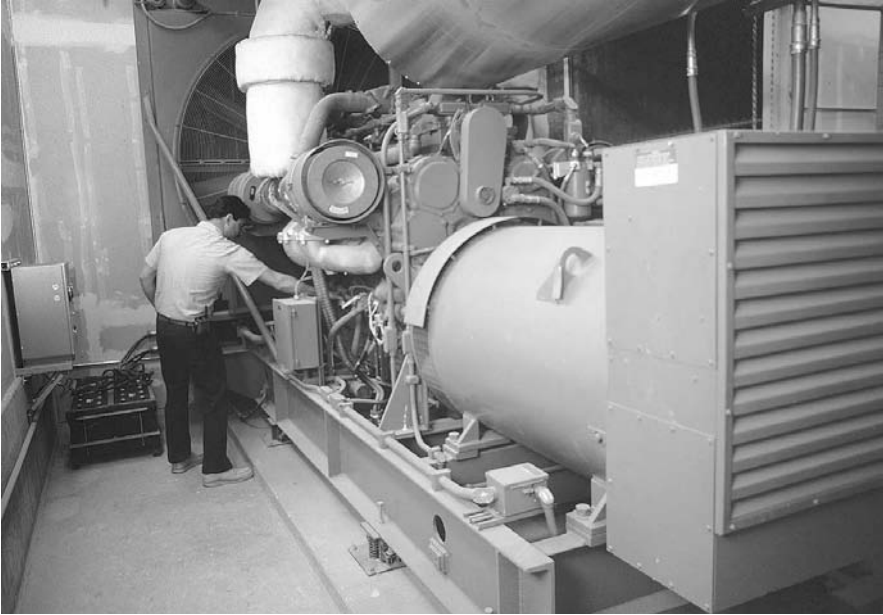

Figure 6-21. Emergency generator. *Source:* Photovault.

the UPS panel loads never experience an outage because those loads are fed by batteries and a dc-to-ac inverter. The generator begins charging the batteries once the transfer switch operates.

When utility power is restored, all loads including emergency loads are turned off while the transfer switch reconnects utility power to the main breaker panel. If the transfer scheme includes synchronization provisions, there might not be a need to deenergize the main breaker panel during the transfer back. When utility power is restored, critical UPS loads again remain powered by the batteries. The battery charger is reconnected to utility power.

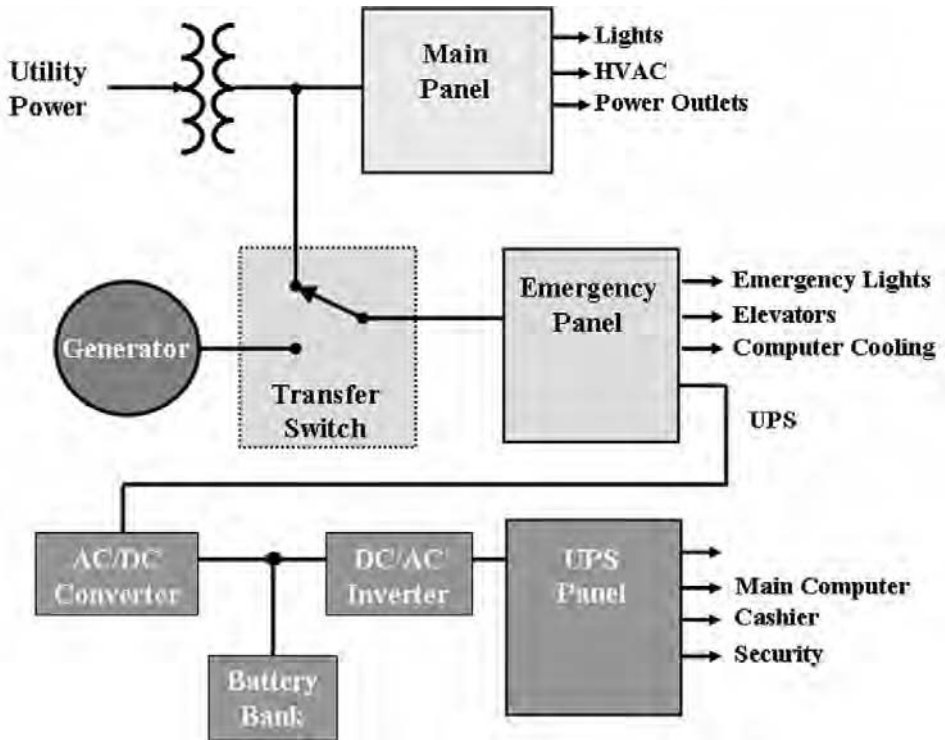

Figure 6-22. UPS system.





---

# SYSTEM PROTECTION

---

## CHAPTER OBJECTIVES

- Explain the difference between “system protection” and “personal protection”*
- Explain the difference between “electromechanical” and “solid state” protective relaying*
- Explain the concept of inverse current and time*
- Describe one-line diagrams and how they are used*
- Explain the function and application of the various types of relays*
- Discuss what is meant by zones of protection*
- Explain the difference between transmission, substation, distribution, and generation protection requirements*
- Describe the steps needed to synchronize a generator onto the power grid*

## TWO TYPES OF PROTECTION

There are two types of protection referred to in electric power systems. The first is *system protection*, having to do with protective relays, fault currents,

effective grounding, circuit breakers, fuses, and so on. The second is *personal protection*, having to do with rubber gloves, insulating blankets, grounding jumpers, switching platforms, tagging, and so on. This chapter discusses the first one—system protection.

The protection of power system equipment is accomplished by protective relaying equipment that is used to trip circuit breakers, reclosers, motorized disconnect switches, and self-contained protection devices. The objective of system protection is to remove faulted equipment from the energized power system before it further damages other equipment or becomes harmful to the public or employees. It is important to understand that system protection is for the protection of equipment; it is not intended for the protection of people.

System protection protects power system equipment from damage due to power faults and/or lightning. System protection uses solid-state and electromechanical protective relays to monitor the power system's electrical characteristics and trip circuit breakers under abnormal conditions. Also, the protective relays initiate alarms to system control, notifying operators of changes that have occurred in the system. The control operators react to these incoming alarms from the system protection equipment.

Another means for providing equipment protection is proper grounding. Effective or proper grounding can minimize damage to equipment, cause protective relays to operate faster (i.e., open circuit breakers faster), and provides additional safety for personnel.

The explanation of system protection will start by first explaining the different types of protective relays and then proceed to explaining how distribution lines are protected, then transmission lines, then substations and generators.

## SYSTEM-PROTECTION EQUIPMENT AND CONCEPTS

System protection, often called *protective relaying*, is composed of relay devices in substations that monitor the power system's voltages and currents through the CTs and PTs and are programmed to initiate "trip" or "close" signals to circuit breakers if the thresholds are exceeded. System control operators are then alarmed of the new conditions. The relays, trip signals, circuit breaker control systems, and the system control equipment are all battery powered. Therefore, the entire system protection operation is functional should the main ac power system be out of service.

## Protective Relays

A protective relay is a device that monitors system conditions (amps, volts, etc., using CTs and PTs) and reacts to the detection of abnormal conditions. The relay compares the real-time actual quantities against preset programmable threshold values and sends dc electrical control signals to trip circuit breakers or other opening devices in an effort to clear an abnormal condition on the equipment it is protecting. When system problems are detected and breakers are tripped, alarm indications are sent to system control and sometimes other protection operations are initiated. As a result, equipment may be deenergized, taken off line, and consumers will be out of power with minimal equipment damage. The operation of protective relays is the stabilizing force against the unwanted destabilizing forces that occur in electric power systems when something happens, such as unanticipated power faults and lightning strikes.

Protective relays are manufactured as two types: *electromechanical* and *solid state*. Electromechanical relays are composed of coils of wire, magnets, spinning disks and moving electrical switch contacts, and are very mechanical in nature. Solid-state relays are electronic and have no moving parts. Most utilities are now installing the more modern solid-state relays. The solid state relay has several advantages over the traditional electromechanical relay. The basic differences are listed below.

### **Solid State**

- Advantages: Multiple functionality, small space requirements, easy to set up and test, self-testing, remote access capability, and they provide fault location information. See Figure 7-1.
- Disadvantages: External power required, software can be complex, and may have many “functional eggs” all in one basket.

### **Electromechanical Relays**

- Advantages: Usually self-powered, simple and single-function design. See Figure 7-2.
- Disadvantages: Normally one relay per phase, difficult to set up and adjust, and require more frequent testing.

## Inverse Current–Time Concept

Typically, protective relays are designed to follow the *inverse current–time* curve as shown in Figure 7-3. In other words, *the time to trip a circuit*



Figure 7-1. Solid-state relays.

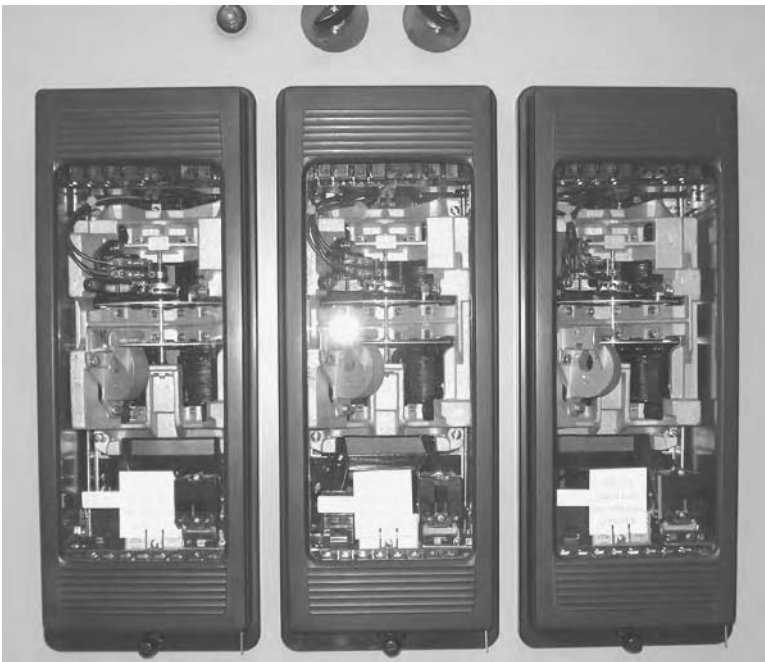

Figure 7-2. Electromechanical relays.

*breaker shortens as the amount of fault current increases.* Therefore, a relay sensing a fault located near a substation would initiate a trip of the breaker faster than if the fault were located down the line because less current flows due to the additional resistance of the wire. Note: each circuit breaker has a fixed amount of time to open a circuit once it receives a trip signal from the relay. Some breakers trip in less than two cycles after receiving a trip signal, whereas some older breakers might take nine cycles to trip.

The time to trip is shown along the horizontal axis and the amount of current flowing in the line (e.g., CT) is shown along the vertical axis. When the actual real-time current is below the horizontal set-point portion of the curve or the *minimum pickup setting*, the time to trip becomes *never* and the relay does not operate. When the current exceeds the *instantaneous setting* on the curve, the time to trip becomes *as fast as possible* and the relay issues a trip command to the breaker without any intentional time delay. Between these two points, the relay engineer adjusts the shape of the curve to meet various *system protection coordination* objectives.

Relay coordination is the term used to create a situation in which the most *downstream* clearing device from the source clears the fault first. Whenever possible, the *upstream* devices act as *back up clearing* devices. The coordination of all the protective relays in the transmission and distrib-

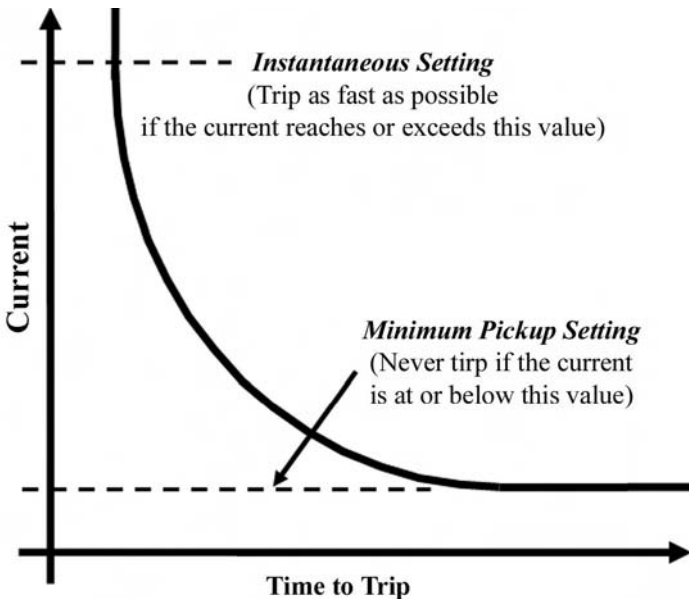

Figure 7-3. Time-versus-current curve.

ution systems, or even a single power line is a very special art and science. There are many key factors that play very important roles in the proper design and coordination of protective relaying.

## One-Line Diagrams

A *one-line diagram* (also referred to as the *single-line diagram*) is a simplified drawing of the system or a portion of the system that shows the electrical placement of all major equipment. One-line diagrams are actually simplified *three-line diagrams* with redundancy removed. Extra information is added to give the engineer or systems operator the full picture of the electrical system, including the system protection schemes. One-line diagrams are very useful for planning maintenance activities, rerouting power after a fault, switching orders to change system configurations, and to view the relationships between smaller sections of the power system and the overall system. There are many uses of one-line diagrams; these are just a few.

Electric utility personnel use one-line diagrams to perform their work activities on a daily basis. Some of the most common uses are discussed below:

- *Line crews* refer to one-line diagrams to know what protective relays are used on the power line being worked, to identify disconnect switch locations for load transfer operations, and to see the relationship to other nearby lines or equipment that are part of the system in question.
- *System operators* use one-line diagrams to identify the electrical placement of breakers, air switches, transformers, regulators, and so on in substations that may indicate alarms and/or needs corrective action. They use one-line diagrams to figure out how to switch the system equipment to restore power.
- *Electrical engineers* use one-line diagrams to understand system behavior and to make changes to the power system to improve performance.
- *Consumers* use one-line diagrams to identify their electrical equipment, circuits, and protection apparatus.

An example of a simple one-line diagram for a distribution substation is shown in Figure 7-4. Note the protective relay numbers in circles. These numbers represent relay functions and are identified in the adjacent table. A complete list of relay number identifications is available through the IEEE as American Standard Device Function Numbers.

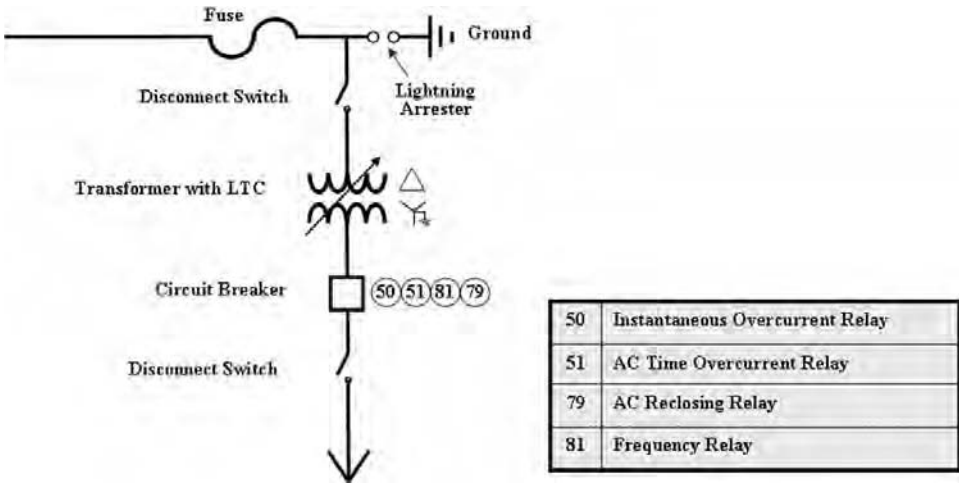

Figure 7-4. One-line diagram.

## DISTRIBUTION PROTECTION

Distribution lines (i.e., feeders) are normally fed radially out of substations. The typical distribution line protection schemes used on radially fed lines normally involve overcurrent protection with reclosing relays and, in several cases, under frequency load-shed relays. This approach to distribution protection is very common; however, variations do exist.

### Overcurrent and Reclosing Relays

Each distribution feeder has a set of overcurrent relays; one for each phase and one for ground overcurrent for a total of four overcurrent relays. Each relay has an instantaneous and a time-delayed capability. The instantaneous and time delay capabilities are interconnected with the reclosing relay. This typical substation relay package must also coordinate with the downstream fuses that are located on the feeder itself.

The overcurrent relays are connected directly to current transformers (CTs) located on the circuit breaker bushings. This enables the monitoring of actual current magnitudes flowing through the breaker in real time. Normally there are four CTs used for each feeder breaker (one for each phase and one for the grounded neutral). Each overcurrent relay has both an instantaneous and a time delay overcurrent relay connected to the CTs. These relays are looking for feeder faults that are phase to ground, phase to phase,

two phases to ground, or three phases. The protection engineer analyzes the available fault current magnitudes for each feeder breaker and recommends relay settings that are later programmed into the relays. These relay settings are periodically tested to make sure they operate properly.

## Typical Distribution Relay Operation

Suppose a lightning strike hits a distribution feeder's "B" phase near the substation and causes a B-phase-to-ground fault. The ground overcurrent relay would sense the increase in ground current and instantaneously send a trip signal to that feeder's breaker. The breaker trips the line; all consumers on the line are now out of power. The overcurrent relay simultaneously sends a signal to the reclosing relay to initiate a timer. After the preset time delay expires in the reclosing relay, the reclosing relay sends a close signal to the same breaker, thus reenergizing the feeder. This first time delay is typically 5 seconds long. If the fault is temporary, as in lightning, all consumers will now be back in service after a brief outage.

A comment about the above scenario: the instantaneous trip setting (sometimes referred to as the *fast trip* setting) on the substation breaker is faster than the time it takes to melt a downstream fuse. When a lightning strike hits a distribution line, the normal sequence of events would be to have all consumers trip off line and about 5 seconds later all consumers are back in service without having any distribution fuses melt.

Now suppose a tree got into a distribution feeder lateral downstream of a fuse. The feeder breaker would trip on instantaneous or fast trip and reclose about 5 seconds later. However, this time the tree is still in the line and the short circuit current flows again because of the tree. In most distribution protection schemes, the instantaneous trip setting is taken out of service after the first trip and the time-delayed overcurrent relay takes over. The removal of the instantaneous relay after the first trip allows time for the fuse to melt and clear the fault on the fused lateral only. Therefore, only those consumers downstream of the blown fuse are out of power. All the other consumers on the feeder experience voltage sag during the time the fuse is melting and then full voltage is resumed. The customers downstream of the fuse remain out of power until a line worker from the power company finds the blown fuse, clears the tree, replaces the fuse, and closes the fuse to restore power.

In the cases in which the fault (i.e., the tree) is far down the main feeder, but is not on a fused lateral, the substation breaker will be tripped by the instantaneous relay. After the first time delay of about 5 seconds, the reclose relay sends a close command to the substation breaker to reenergize the



feeder. If the tree is still in the line after the reclose, the breaker will trip again by the time delay over current relay. After another preset time delay (about 15 seconds) the reclose relay sends another close command to the breaker to reenergize the feeder again. By this time, the tree branch may have been cleared from the fault. If not, the fault current flows again and the time delay overcurrent relay trips the feeder for the third time. All consumers are out of power again. Now, after another time delay (this time maybe 25 seconds) the line is automatically closed for the fourth time. If the fault is still present, the overcurrent relay trips the breaker for the fourth time and *locks out*. The reclosing relay no longer sends a close signal to the breaker and all customers remain out of power until the line workers clear the fault (i.e., the tree), reset the relays, and close the breaker. (Note: there is a programmable reset timer that places the sequence back to the beginning, i.e., initial trip being fast.)

As stated earlier, there are variations to this distribution scheme; however, what was described above is very common in the industry. **Caution:** a distribution line can become re-energized several times automatically. A similar scenario would occur in a car-pole accident in which a power line conductor falls to the ground. The conductor could and probably will reenergize multiple times before the line “locks out.” Also, system control operators could test the line remotely to see if the line will remain energized after a lockout before a line worker is sent out to *patrol the line*, only to discover that the problem is a car-pole accident. The example above illustrates why *it is very important to realize that a power line can be reenergized at any time and to always stay clear of a fallen line.*

## Underfrequency Relays

In an effort to stop or prevent a cascading outage, *underfrequency relays* are used to shed load when the system frequency is dropping. Underfrequency relays are also referred to as *load-shed* relays. The system frequency will drop if there is more load than there is generation (i.e., load-generation imbalance). When generation or an important tie line is tripped, system frequency can drop and load-shed relays will start to trip feeder breakers as a *remedial action* to balance load and generation. This automatic load-shedding scheme can trip up to 30% of total load in an effort to prevent the system from experiencing a wide-scale outage.

Keep in mind that the standard frequency in the United States is 60 hertz and the typical underfrequency relay settings are chosen based on the following guidelines:

At 59.3 Hz, shed a minimum of 10% of load.

At 59.0 Hz, shed a minimum of 10% of load.

At 58.7 Hz, shed a minimum of 10% of load.

At 58.5 Hz or lower, the system may take any action it deems necessary, including a domino effect disturbance.

Some systems start diesel engine generators and/or combustion turbines automatically upon underfrequency detection. All of these remedial action schemes are intended to balance generation and load and stop the possibility of a cascading outage disturbance.

## TRANSMISSION PROTECTION

Transmission protection is much different than distribution protection simply because transmission is usually not radially fed. Normally transmission systems have multiple feeds to a substation and transmission lines must have special protective relaying schemes to identify the actual faulted transmission line. To complicate matters, some transmission lines might have generation at the other end that contributes to the fault current while others are transporting generation from different lines and substations. Further, some transmission lines are only serving load at their far end. The application or concept of *zone relaying* (sometimes called *distance* or *impedance relaying*) with directional overcurrent capability is used to identify and trip the faulted transmission lines.

The direction of the fault current verifies that a particular breaker needs to trip. For example, excessive current must be leaving the substation as opposed to just excessive current magnitude. Both fault current magnitude and direction are required for transmission breakers to trip.

As another example, notice the location of the fault on the transmission one-line diagram in Figure 7-5. Notice the multiple transmission lines, generators, transformers, and buses for the power system. A fault on one of the transmission lines requires breakers on both ends of that line to trip. Zone relaying identifies the faulted line and trips the appropriate breakers. Also, Zone relaying provides backup tripping protection should the primary protection scheme fail.

### Zone or Distance Relays

Figure 7-6 shows the concept of zone relaying. In this particular scheme, each breaker has three protection zones. For example, if breaker “A” has

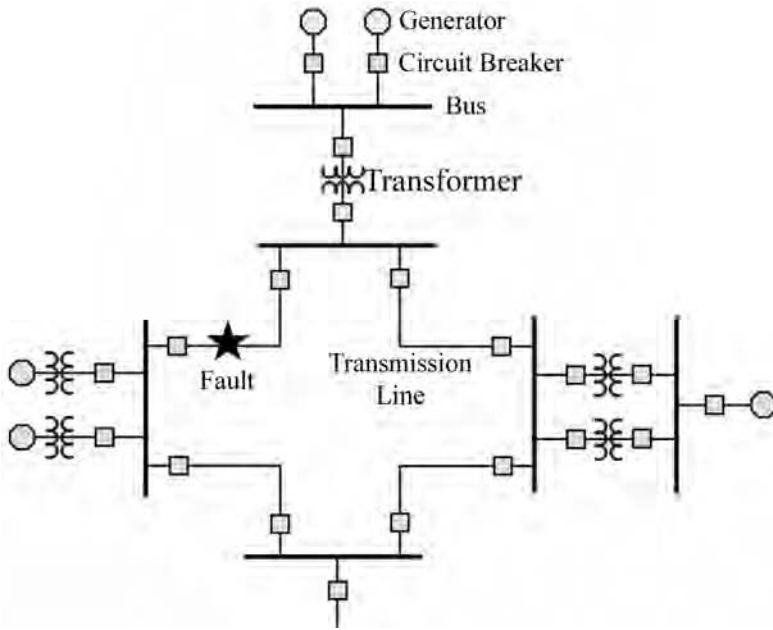

Figure 7-5. Transmission fault.

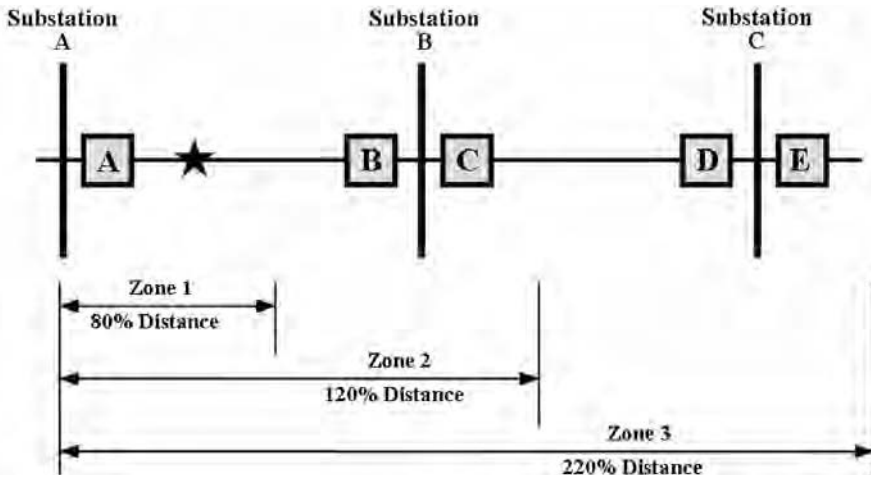

Figure 7-6. Zone protection. Courtesy of Alliant Energy.

three zones looking toward the right (as shown), breaker “B” would have three zones looking left (not shown), breaker “C” would have three zones looking right, and so on. Typical zone relay settings are as follows.

### **Zone 1 Relays**

The Zone 1 relay is programmed to recognize faults that are located in 80% to 90% of the line section and trip instantaneously (i.e., one to three cycles).

In this example, the fault is in Zone 1 of breaker “A” and, therefore, breaker “A” is tripped at high speed. High speed implies that the relay is set for instantaneous and fault clearing depends only on the time it takes for the breaker to open and interrupt the current.

### **Zone 2 Relays**

The Zone 2 relay is programmed to recognize faults that are located in about one line section plus about half of the next line section (approximately 120% to 150%). The trip is time delayed to coordinate with Zone 1 relays.

In this example, the fault is in Zone 2 of breaker “B” and would trip after a short time delay. However, in zone protection schemes, fiber optic, microwave, power line carrier, or, copper circuit communications systems are used to *transfer trip* the line’s opposite-end breaker when appropriate. In this case, breaker “A” would send a transfer trip signal to substation B, telling breaker “B” to bypass its Zone 2 time delay setting and trip immediately. This provides high-speed line clearing at both ends even though there is a built-in time delay in Zone 2 relays.

Note: if the fault were in the middle of the line, both ends would trip Zone 1 at high speed.

### **Zone 3 Relays**

Zone 3 relays are set to reach the protected line section plus the next line section plus an additional half line section as a backup (approximately 250%). The trip is time delayed more than Zone 2 to coordinate with Zone 2 and Zone 1 protection. Zone 3 provides full backup.

In the example above, Zone 3 backup protection would not be involved. Should a Zone 2 breaker fail to trip the line, then Zone 3 would trip as a backup.

The various types of telecommunications systems used in electric power systems for system protection schemes like this are discussed in Chapter 9.

## SUBSTATION PROTECTION

Substation protection is generally accomplished using *differential relays*. Differential relays are used to protect major transformers and buses from faults. Substation differential relays are very similar in concept to GFCI breakers discussed earlier in the residential wiring section of Chapter 6. In the case of the GFCI receptacle breaker, the current leaving the hot leg (black wire) must equal or be within 5 milliamps of the current returned in the neutral (white wire) or the GFCI breaker will trip. Similarly, differential relays used in substation transformers and buswork monitor the current entering versus the current exiting the protection zone. These concepts are discussed below as they apply to substation transformers and bus protection schemes.

### Differential Relays

*Differential relays* are generally used to protect buses, transformers, and generators. Differential relays operate on the principle that the current going into the protected device must be equal to the current leaving the device. Should a differential condition be detected, then all source breakers that can feed fault current on either side of the device are tripped.

### Transformer Differential Relays

Current transformers (CTs) on both the high side and low side of the transformer are connected to a *transformer differential relay*. *Matching CTs* are used to compensate for the transformer windings turns ratio. Should a differential be detected between the current entering the transformer and exiting the transformer after adjusting for small differences due to losses and magnetization, the relay trips the source breaker(s) and the transformer is deenergized immediately.

### Bus Protection Schemes

*Bus differential relays* are used to protect the bus in a substation. The current entering the bus (usually exiting the power transformer) must equal the current leaving the bus (usually the summation of all the transmission or distribution lines). Line-to-ground faults in the bus will upset the current balance in the differential relay and cause the relay contacts to close, thus initiating trip signals to all source breakers.

## Over- and Undervoltage Relays

Another application of system-protective relays is the monitoring of high and low bus voltage. For example *overvoltage relays* are sometimes used to control (i.e., turn off) substation capacitor banks, whereas *undervoltage relays* are sometimes used to switch on substation capacitor banks. Over- and undervoltage relays are also used to trip breakers due to other abnormal conditions.

## GENERATOR PROTECTION

The chances of failure of rotating machines are small due to improved design, technology, and materials. However, failures can occur, and the consequences can be severe. It is very important that proper generation protection is provided. This section summarizes the techniques used to protect the very expensive generators.

When a generator trips offline for any reason, it is extremely important to determine exactly what caused the generator to trip. This condition should not happen. Some of the undesirable operating conditions for a generator to experience and the protective scheme or device used to protect the generator are listed below.

### Winding Short Circuit

Differential relays normally provide adequate protection to guard against shorted winding in the generator stator. The current entering the winding must equal the current leaving the winding or a winding-to-ground fault may be present and the generator breaker will be tripped.

### Unbalanced Fault Current

The very strong magnetic forces that are imposed on a generator during fault conditions, especially an *unbalanced fault* (e.g., a line-to-ground fault as opposed to a three-phase fault), cannot be sustained for a long period of time. This condition quickly causes rotor overheating and serious damage. To protect against this condition, a reverse rotation overcurrent relay is used to detect these conditions. Reverse rotation (i.e., *negative sequence*) relays look for currents that want to reverse the direction of the rotor. *Positive sequence* currents, for comparison, rotate the rotor in the correct direction.

## Frequency Excursion

A generator's frequency can be affected by over- and underloading conditions and by system disturbances. Frequency excursions cause possible overexcitation problems. Excessive underfrequency excursion conditions can affect auxiliary equipment such as station service transformers that power ancillary equipment at the power plant. Underfrequency relays and volts per hertz relays are often used to protect against excessive frequency excursions.

## Loss of Excitation

When loss of generator excitation occurs, reactive power flows from the system into the generator. Complete loss of excitation can cause the generator to lose synchronism. Therefore, loss of excitation (i.e., undervoltage relay) is used to trip the generator.

## Field Ground Protection

Field ground protection is needed to protect the generator against a possible short circuit in the field winding (i.e., a fault between the rotor winding and stator winding). A fault in the field winding could cause a severe unbalance and generator vibration that could possibly damage the generator's rotor shaft.

## Motoring

This condition is attributed to insufficient mechanical energy onto the shaft by the prime mover. When this occurs, power flows from the system into the generator, turning the generator like a motor. Motoring can cause overheating of the turbine blades. Protection against generators acting in a motoring condition is highly desirable and usually results in tripping the generator.

## GENERATOR SYNCHRONIZATION

The purpose of a synchronizing relay is to safely connect two three-phase lines together or to place a spinning generator online. Figure 7-7 shows a generator breaker that needs to be closed. There are four conditions that

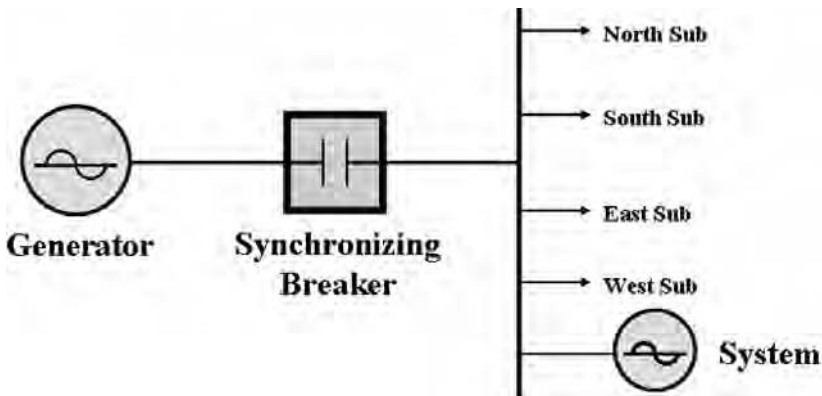

Figure 7-7. Generator synchronization.

must be met first in order to safely connect two three-phase systems together. Failure to meet these four conditions can result in catastrophic failure of the equipment (i.e., generator). Note: *permissive relays* are used in circuits like this to block the closing of circuit breakers until all conditions are met. An analogy to “permissive relays” would be to require that your seat belt be buckled before your car will start.

### Condition 1. Frequency

The generator must have the same frequency as the system before the circuit breaker can be closed. Not matching the frequency on both sides of the breaker before closing could cause the generator to instantly speed up or slow down, causing physical damage or excessive power transients.

### Condition 2. Voltage

The voltage must be close to the same magnitude on both sides of the breaker connecting the systems together. Widely differing voltages could result in excessive voltage transients.

### Condition 3. Phase Angle

The relative phase angle of the generator must be equal to the phase angle of the system before the synchronizing breaker can be closed. (Note: it is only necessary to match one phase on both sides of the breaker so long as it is the



same phase.) To add clarification to this important condition, the frequency on both sides of the breaker could be 60 hertz; however, one side might be entering the positive peak of the cycle while the other side is entering the negative peak. This is an unacceptable condition.

### Condition 4. Rotation

Rotation is normally established during installation. Rotation has to do with matching phases A, B, and C of the generator with phases A, B, and C of the system. Once the rotation has been established, this situation should never change.

### Synchronizing Procedure

Synchronizing relays and/or synchrosopes such as the one shown in Figure 7-8 helps to match the generator and the system for a graceful connection. Synchrosopes display the relative speed of the generator with respect to the system. A needle rotating clockwise indicates that the generator is spinning slightly faster than the system. The normal procedure for closing the breaker is to have the generator spinning slightly faster than the system or at least accelerating in the positive direction when the breaker is closed. Once the

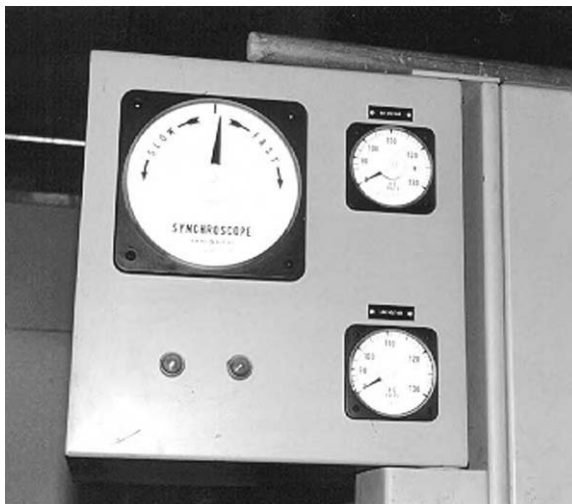

Figure 7-8. Synchroscope.

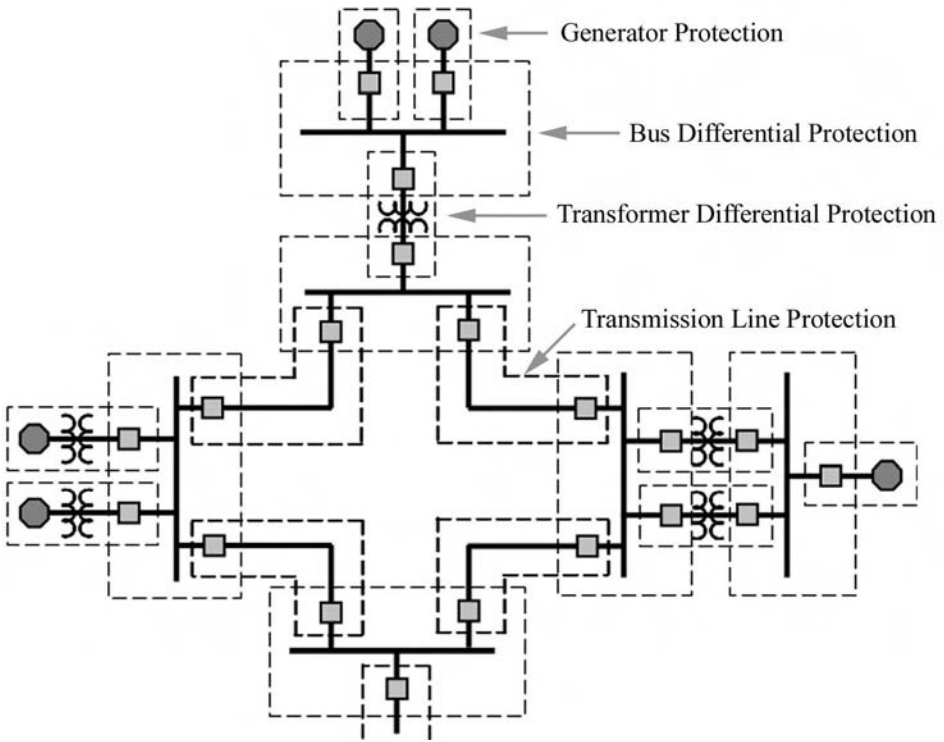

Figure 7-9. Transmission protection.

breaker is closed, the needle stops spinning, therefore, the generator will immediately output power into the system.

## OVERALL TRANSMISSION PROTECTION

The drawing in Figure 7-9 shows the many zones of protection found in a major interconnected electric power system. All the zones *overlap* to provide a full complement of protection against line, bus, generator, and transformer faults. Overlap is achieved using CTs on opposite sides of equipment being protected.

---

# INTERCONNECTED POWER SYSTEMS

---

## CHAPTER OBJECTIVES

- Explain why interconnected power systems are better than isolated control areas*
- Describe the major power grids in North America*
- Discuss the term “Independent System Operator” (ISO) and their purpose*
- Explain the function and duties of “balancing authorities”*
- Explain how power is scheduled and transported over tie lines*
- Explain power grid reliability, stability, and voltage control*
- Discuss system demand and generator loading*
- Explain the purposes of “spinning reserve” and “reactive supply”*
- Describe how excess generator capacity can be sold*
- Explain the conditions that need monitoring to maintain a reliable power grid*
- Discuss what system control operators do to prevent a major disturbance*
- Explain what happens when a system undergoes a major disturbance*

## INTERCONNECTED POWER SYSTEMS

Interconnected power systems (i.e., *power grids*) offer many important advantages over the alternative of independent power islands. Large power grids are built to take advantage of electrical *inertia* for the purpose of maximizing system stability, reliability, and security. (Inertia is discussed later in this chapter.) Also, in today's regulatory atmosphere, large interconnected power grids offer new opportunities in sales/marketing, alternative revenue streams, and resource sharing for a price.

Electric power systems became interconnected power grids a long time ago. Interconnected systems stabilize the grid, which, in turn, improves reliability and security. Interconnection helps reduce the overall cost of providing reserves. Interconnected systems help maintain frequency, avoid voltage collapse, and reduce the chance of undesirable load-shed situations.

Further, interconnected power companies benefit from information exchange opportunities. These benefits include joint planning studies, mutual cooperation during emergencies (such as storm damage), and sharing of new technologies, especially in the areas of telecommunications, system control centers, and energy management.

Please note that the emphasis of this chapter is on electrical fundamentals of interconnected power systems; the regulatory and power agency organizations aspects will be addressed but not elaborated on.

## THE NORTH AMERICAN POWER GRIDS

The *North American Electric Reliability Corporation* (NERC) is responsible for ensuring that the bulk electric power system in North America is reliable, adequate, and secure. NERC was formed in 1968 and has operated successfully as a self-regulatory organization, relying on reciprocity and the mutual self-interest of all those involved in the production, transmission, and distribution of electricity in North America. NERC has recently acquired the duties of overseeing operating standards compliance with enforcement powers.

The massive interconnected power grid system in the United States and Canada is broken down into four separate grids: the western grid, the eastern grid, Quebec, and Texas. Figure 8-1 shows the power grid structure in North America.

The three grids are composed of regions and/or utilities having interconnected transmission lines and control centers. They share similarities such

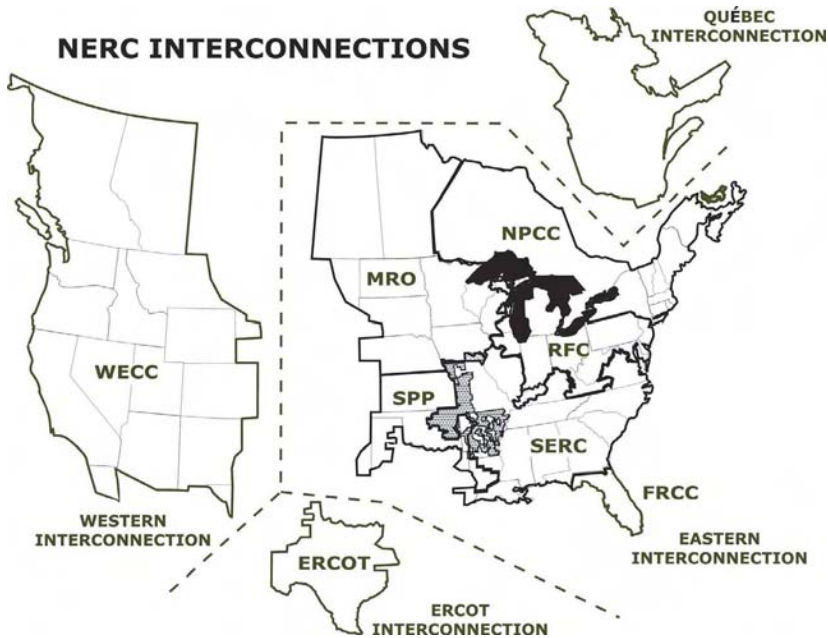

Figure 8-1. Power grid interconnections.

as 60 Hz frequency and system transmission voltages, yet they have specific individual requirements such as ownership, topography, and fuel resources. All the generation units in each grid are synchronized together, sharing total load, and are providing very large, reliable power grids.

## REGULATORY ENVIRONMENT

The regulatory environment in the electric power industry continues to change, causing some uncertainty in the way companies are structured. Most electric companies are trying to establish or position themselves as being generation, transmission, or distribution companies to align with the new regulatory framework.

Due to the governmental changes that have resulted in a deregulated power industry, and to avoid potential conflicts, employees in wholesale power contracts departments must remain physically separated from employees dealing with generation and transmission because of the unfair advantages or disadvantages in an open market environment. Some view hav-

ing knowledge of a company's strengths, weaknesses, and future construction projects as having an unfair advantage. Similar rules exist for the separation of transmission and distribution employees where necessary.

Figure 8-2 illustrates where the actual divisions occur in the deregulated model. Note that the division is between the windings of the transformers. However, actual equipment ownership arrangements are defined on a case-by-case basis.

## Independent System Operators (ISOs) and Regional Transmission Operators (RTOs)

The *Federal Energy Regulatory Commission* (FERC) now requires that power entities form joint transmission operations areas known as *Regional Transmission Operators* (RTOs) or *Independent System Operators* (ISOs). These groups are charged with the requirements that all parties work together, have equal access to information, and provide a marketplace for energy exchange.

In the United States, an Independent System Operator or ISO, is a federally regulated regional organization that coordinates, controls, and monitors the operation of the electrical power system of a particular service area, typically a single state. The Regional Transmission Operators (RTOs), such as the Pennsylvania–New Jersey–Maryland Interconnection (PJM), have similar functions and responsibilities but operate within more than one U.S. state.

The ISO or RTO acts as a marketplace for wholesale power now that the electricity market has been deregulated since the late 1990s. Most ISOs and RTOs are set up as nonprofit corporations using a governance model developed by the FERC in April 1996. Also, FERC Order 888/889 required *open access* of the grid to all electricity suppliers and mandated the requirement

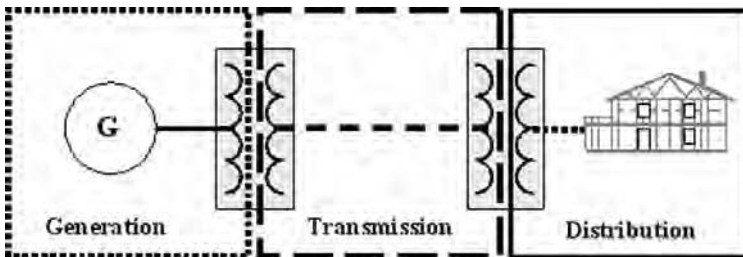

Figure 8-2. Regulatory divisions.

for an *Open Access Same-Time Information System (OASIS)* to coordinate transmission suppliers and their customers.

The Canadian equivalent of the ISO and RTO is the *Independent Electricity System Operator (IESO)*.

There are currently five ISOs operating in North America:

1. Alberta Electric System Operator (AESO)
2. California ISO (CAISO)
3. Electric Reliability Council of Texas (ERCOT), also a Regional Reliability Council (see below)
4. Independent Electricity System Operator (IESO), operates the Ontario Hydro system
5. New York ISO (NYISO)

There are currently four RTOs operating in North America:

1. Midwest Independent Transmission System Operator (MISO)
2. ISO New England (ISONE), an RTO despite the ISO in its name
3. PJM Interconnection (PJM)
4. Southwest Power Pool (SPP), also a Regional Reliability Council (see below)

## **Regional Reliability Councils**

The North American Electric Reliability Corporation's (NERC), whose mission is to improve the reliability and security of the bulk power system in North America, consists of eight member Regional Reliability Councils. These members come from all segments of the electric industry: investor-owned utilities; federal power agencies; rural electric cooperatives; state, municipal and provincial utilities; independent power producers; power marketers; and end-use customers. These entities account for virtually all the electricity supplied in the United States, Canada, and a portion of Baja California Norte, Mexico.

1. Electric Reliability Council of Texas, Inc. (ERCOT)
2. Florida Reliability Coordinating Council (FRCC)
3. Midwest Reliability Organization (MRO)
4. Northeast Power Coordinating Council (NPCC)

5. ReliabilityFirst Corporation (RFC)
6. SERC Reliability Corporation (SERC)
7. Southwest Power Pool, Inc. (SPP)
8. Western Electricity Coordinating Council (WECC)

## The Balancing Authority

The North American Electric Reliability Corporation (NERC) rules require that all generation, transmission, and load operating in an interconnection must be included in the metered boundaries of a *balancing authority*. Before deregulation, a balancing authority was almost synonymous with a utility company. The utility company controlled transmission and generation and thus was responsible for the balance of all generation and load. By definition, all of the generation, transmission and load for that utility were inside the control area of the utility, in essence a balancing authority. However, with today's deregulation, balancing authorities are not necessarily individual utility control areas. Balancing authorities are approved by NERC and they may control generation in multiple utilities.

The balancing authority is responsible for maintaining online generation reserves in the event that a generator trips offline. Also, the balancing authority must be capable of controlling generation through the *automatic generation control (AGC)* system. The balancing authority is also responsible for communicating electronically all data required to calculate the *area control error (ACE)*, the difference between scheduled and actual tie line flow. (Note, AGC and ACE are discussed in more detail later in this chapter.)

## INTERCHANGE SCHEDULING

In reference to Figure 8-3, the net power flowing on all the *tie lines* between the islands A, B, C, and D must add up to zero unless intercompany power sales are taking place, or the net interchange of a single company in an interconnected system is equal to the sum of the tie line flows of that company to other companies. Each tie line is metered for accurate accounting. The power flowing on these tie lines is scheduled with agreements on pricing. Pricing agreements include provisions for special circumstances such as emergencies, planned outages, and *inadvertent* power flow. The error between scheduled and actual power flow (i.e., inadvertent) is properly accounted for and settled between the parties involved.



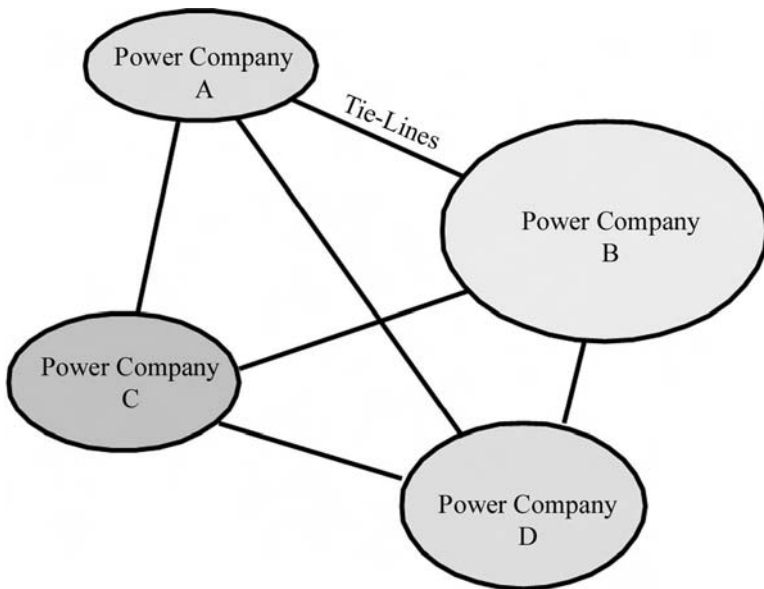

Figure 8-3. Interconnected systems.

## Area Control Error

The term *ACE* (*area control error*) is used to describe the instantaneous difference between a balancing authority's net actual interchange flow and the scheduled interchange flow, taking into account the effects of frequency and metering error. The term *flat tie line control* is used when only tie line flows are closely monitored in consideration of the actual interchange flow. The term *flat frequency control* is used when only frequency is carefully controlled. When both tie line flow and frequency are carefully controlled by AGC (*automatic generation control*), the term is called *tie line bias*. Tie line bias allows the balancing authority to maintain its interchange schedule and respond to interconnection frequency error. The AGC system is part of the *energy management system* (EMS). (Note: the computer program tools used by system operators that make up the EMS are discussed in more detail in Chapter 9, System Control Centers and Telecommunications).

Tie line bias is carefully monitored and reported for all tie lines. Bias is the accepted standard operating constraint for controlling ACE. Carefully monitoring and adjusting tie line flow helps keep the interconnected system stable.

## Time Correction

The power grids adjust their generation pattern to make sure real time (measured in seconds) matches grid frequency (i.e., 60 cycles per second). Time error is the difference between the time measured at the balancing authority(ies) based on 60 cycles per second and the time specified by the National Institute of Standards and Technology. Time error is caused by the accumulation of frequency error over a given period. Therefore, adjusting bulk generation, hence, shaft speed, corrects time error.

For example, there are 60 cycles in a second, 3,600 cycles in a minute and 5,184,000 cycles in a day. The grid frequency must increase or decrease if the actual number of cycles generated does not match the exact same number of cycles based on real time. Time correction is a very important condition that must be met on a daily basis. The frequency is closely monitored at key locations in the grid to assure that only subtle changes in system frequency are necessary to continually match time and frequency.

## INTERCONNECTED SYSTEM OPERATIONS

Now that we have covered the major building blocks of a power system (i.e., generation, transmission, substations, distribution, consumption, protection, and the elements of power grid organization), the next discussion explains the fundamental concepts, constraints, and operating conditions that make an interconnected power system stable and reliable.

### Inertia of the Power Grid

*Inertia* is one of the main reasons interconnected systems are built. Inertia is the tendency of an object at rest to remain at rest or of an object in motion to remain in motion. The larger the object, the more inertia it has. For example, a rotating body such as a heavy generator shaft will try to continue its rotation. The more spinning generators connected together in the power grid, the more inertia the grid has available to resist change. Power systems boost stability and reliability by increasing inertia.

The best way a power system can maintain electrical inertia is to have an interconnected system of several rotating machines. Note, the word “machine” is used opposed to “generator” because both motors and generators contribute to electrical inertia. Note that generation plants that do not have spinning members, such as solar voltaic plants, do not add to the system’s

inertia. The more inertia a power system has, the better. *Power system stabilizers* (PSS) are installed on generators to compensate for decreasing inertia under fault conditions. The electromechanical *governors* that control the amount of steam to the turbines, for example, are controlled by PSS during fault conditions to automatically oppose normal governor responses in order to maintain inertia.

Figure 8-4 illustrates the concept of inertia and frequency stability in a steady-state interconnected power system. Suppose these trucks are carrying load and are all traveling at 60 miles per hour. They are all helping each other carry the load up the hill. As the hill incline increases (i.e., system losses plus load are increasing), the trucks must open their throttles (i.e., governors) in order to maintain speed at 60 miles per hour. If the incline got too great for these trucks to travel at 60 mph, additional trucks would have to be added in order to maintain speed (i.e., frequency). As the incline decreases (i.e., less losses and load), the trucks must close their throttles in order to maintain speed. If significant load is removed, some trucks would not be needed and could be taken off line while the 60 mph speed is maintained. (The 60 mph is analogous to system frequency, the rubber bands are analogous to transmission lines, and the trucks are analogous to generators. The trucks are carrying the load.)

In a large-scale integrated power grid, very similar concepts and actions apply. The grid generators are working together to share the load. Their electrical output frequency is a joint effort. They all slow down when load is added and they all tweak their rubber bands (i.e., transmission lines) when excitation changes. All generator units and transmission lines work together as a system to produce a highly reliable electric service that balances generation with load at a constant frequency and good voltage.

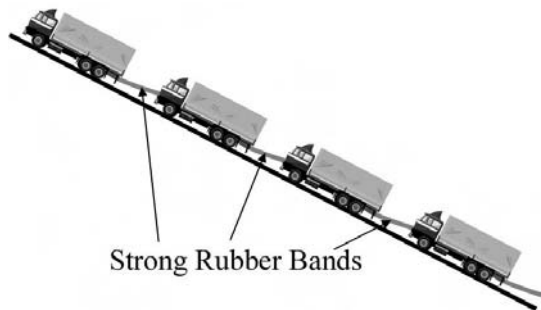

Figure 8-4. Steady state.

## Balanced Generation Conditions

Power out of the generator is a function of rotor angle. Zero power out has a zero rotor angle and maximum power out has a 90 degree rotor angle. When two same-size generators are connected to one bus, as shown in Figure 8-5, they are producing the same amount of power and their rotor angles are equal. This represents a balanced generation situation. Three generators would look the same but with more combined output power.

## Unbalanced Conditions

When two generators of the same size are connected to one bus and their rotor angles are not equal, as shown in Figure 8-6, the output power of one generator is different from the other. This represents an unbalanced generation situation. Increasing the exciter current increases the rotor's magnetic field. Increasing the steam to the turbine at the same time the exciter current is increased overcomes the constraint against rotor speed and more power goes out into the system at the same frequency. Thus, increasing the exciter and steam increases the rotor angle and power out into the system.

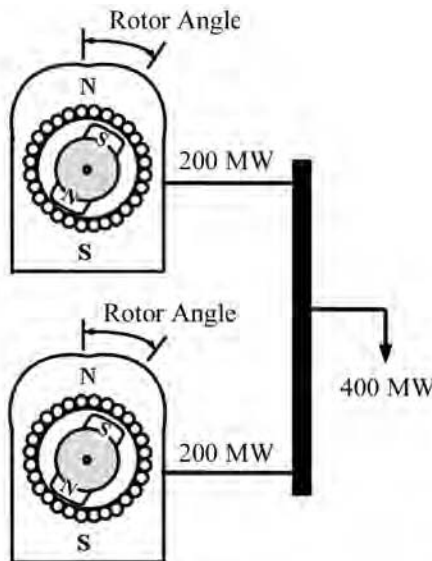

Figure 8-5. Balanced generation.

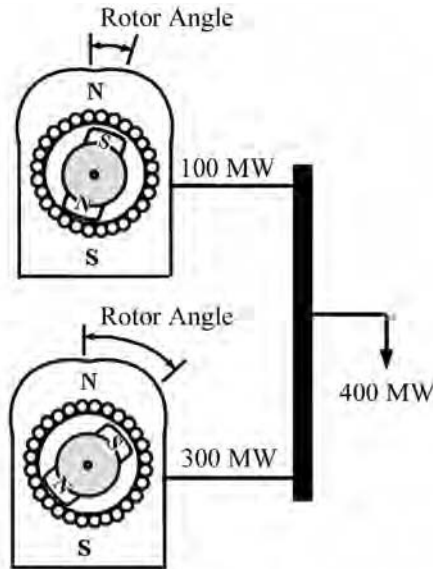

Figure 8-6. Unbalanced generation.

Note: when two generating units are connected to the same bus and one unit is larger than the other but their output power is the same, the larger unit will have a smaller rotor angle than the smaller unit. Since maximum power out occurs at a rotor angle of 90 degrees, the larger unit would not have as great a rotor angle for the same amount of generator power.

## System Stability

Stability is the term used to describe how a power grid handles a system disturbance or power system fault. A stable system will recover without loss of load. An unstable system could trip generator units, shed load, and, hopefully, settle down without a large scale blackout.

System stability is directly related to generator loading. The generator's rotor angle changes when loading on the generator changes. As shown in Figure 8-7, a stable system that undergoes a system fault will have its generator rotor angles change/swing and then converge back to a stable steady state. As long as the rotor angle converges back to stable, the system will eventually become stable. This is obviously a desired situation after a major line fault.

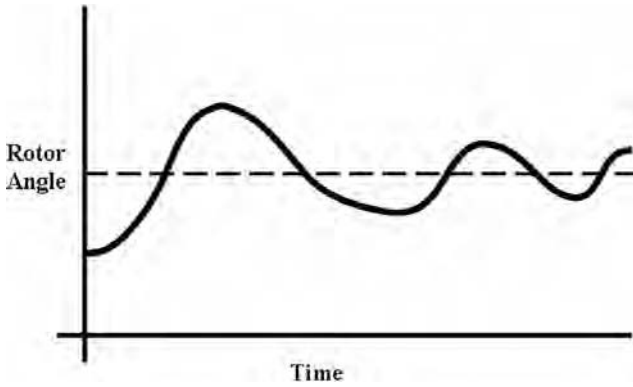

Figure 8-7. System stability.

### System Instability

Since the generator rotor angle changes when load conditions change, sudden large changes in generator loading can cause great swings in rotor angle. As shown in Figure 8-8, these great swings can cause the generator to become unstable and trip offline. Loss of generation causes underfrequency conditions on the rest of the system and unless generation-load balance is achieved quickly, load will be shed and outages will occur. Loss of load can cause more generators to trip as a result of excessive swings in their rotor angles. The system will eventually become unstable unless something is done to reestablish balance between generation and load. Therefore, ex-

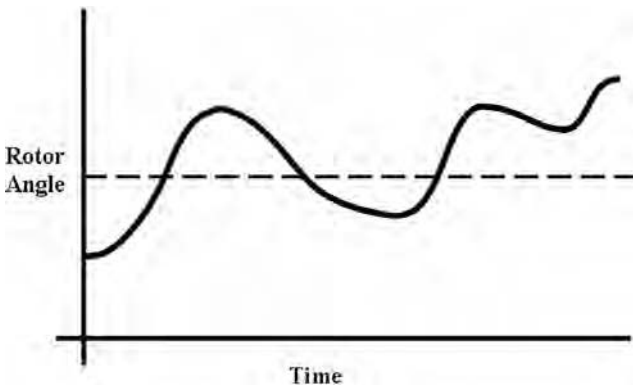

Figure 8-8. System instability.

treme load variations can cause a system to become unstable and possibly result in a widespread outage or full system blackout.

## Conditional Stability

Each generator unit and the grid as a whole normally operate in a condition called *conditionally stable*. For example, in Figure 8-9, if the ball is pushed up the wall to the left, it will roll back down to the bottom then to the right and, hopefully, settle back to the bottom. But if the ball is pushed up the wall too far and let go, it will actually keep on rolling up the right side and perhaps go off the edge, resulting in a generator tripping offline.

This analogy describes what happens to power system generators with regard to their rotor angles. Depending on the system fault (overcurrent condition), load breaker trips (undercurrent condition), or some other power disturbance that causes rotor angle instability, there is a conditional limit as to whether the unit or system will regain stability. Otherwise, generation and/or load breakers trip and the system becomes unstable, resulting in cascading outages and possibly major wide-area blackouts.

Most of the effort in analyzing power systems is deciding on the operational constraints and trying to determine the limits of conditional stability. The engineering and planning departments are constantly analyzing load additions; possible single, double, and triple contingency outages; impacts of new construction; and all other planned or unplanned changes to the system to determine operating constraints. This engineering and planning effort tries to determine the fine line between maximum uses of system capacity versus stability after a contingency. These parameters can all change during peak and nonpeak conditions, equipment maintenance outages, and so on.

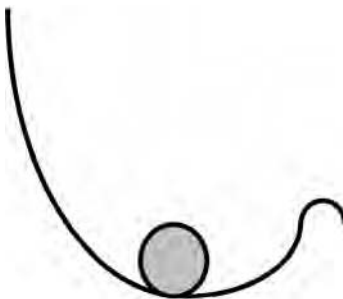

Figure 8-9. Conditional stability.

## Unit Regulation and Frequency Response

A stable system is one in which the frequency remains almost completely constant at the design value of 60 Hz. This is accomplished through unit regulation with quick frequency response. Only very small deviations from this standard frequency should occur. Generating units control system frequency. Generators that are on line as “load following units” usually provide the necessary unit regulation and frequency response actions that ensure that the system is operating at 60 Hz at all times.

Note that electric utilities are always in a “load following” mode of operation. That is, consumers turn loads on and off at will, without notifying the utility. As a result, the utilities must adjust generation to the randomly changing load demands and predict/plan for future expectations.

## SYSTEM DEMAND AND GENERATOR LOADING

Total system demand is the net load on the system within a controlled area that must be served with available internal generation and tie line import resources. Generators are put on the system according to their *incremental cost* and by the type of generator used. Some generator types are designed as *base load units* that are capable of running 24/7, whereas others are designed as *load peaking units*. The load peaking units generally cost more to operate than the base load units. Another category of generator types are *load following units*. Load following units can be used as expensive base load units and can operate 24/7 but they are still typically not as expensive to operate as peaking units. Other generator types such as wind powered are used whenever available.

A typical 24 hour demand curve showing internal generation requirements is shown in Figure 8-10. This demand is supplied by base-load, load-following, and peaking generation units. Generator Units 1, 2, and 3 are considered base-load units (least expensive to operate and designed to operate 24/7). Generator Units 4 and 5 are considered load-following units (used to maintain ACE and tie line bias). Generator Units 6 and 7 are considered peaking units (usually the most expensive to operate, yet can start quickly and help balance load with generation.)

## Spinning Reserves

Normally, it takes several hours to restart a major fossil-fueled generator and sometimes days to restart nuclear plants after a trip. *Spinning reserve* is the



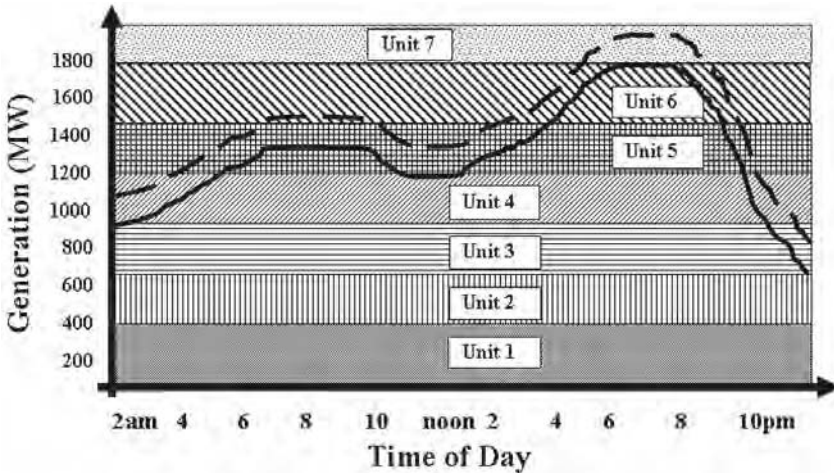

Figure 8-10. Generator loading.

term used to describe generation capacity that is readily available to go online almost immediately without operator intervention should an online generator or an import transmission line trip due to a system disturbance. There are two types of spinning reserves: those necessary to meet changing load conditions and those that must respond quickly in the event of a disturbance. Generation units that meet changing load conditions are usually the “load-following” units. The other types of spinning reserve units are those that can respond quickly to help bring back system stability after the loss of a generator or import tie line. These quick-response units can be originally offline peaking units. However, spinning reserve requirements are set by criteria and standards published by the North American Electric Reliability Corporation (NERC).

Normally, *operating spinning reserves* are supplied by generation units that are already online meeting the changing load patterns. *Supplemental reserves* are units that are spinning but not serving load. Typically, units that account for between 5% and 10% of the load being served are also serving as spinning reserves. Other spinning reserve resources are peaking generators, combustion turbine generators, and, possibly, load-shedding protection schemes.

## Capacity for Sale

Since the operator has the option to *import or export energy* from other areas, there is also an opportunity to *sell excess energy* on the spot market or

through long-term sales agreements. The ability to make these sales is dependant on loading and available generation. For example, the northwest area of the United States usually has an abundance of hydroelectric generation for sale. This capacity is above the utility load requirement and excess generation capacity can be sold on the open market.

Referring to Figure 8-10, generator units 4, 5, 6, and 7 could be run near full load to provide energy for sale to other interconnected companies.

## Reactive Reserves and Voltage Control

Reactive power must be supplied for inductive loads. The supply of this reactive power must come from generation units, switchable capacitor banks, and tie line contract agreements, and they must be readily available to the system operator. In general, power contracts outline the requirements for generation to supply reactive power and maintain limits on voltage conditions. These resources can be shared at a cost. Therefore, real power and reactive power can be bought and sold on the open market, but within the constraints of ensuring a reliable system.

System voltage is controlled through the use of reactive supply resources such as generation, switchable capacitors, inductive reactors, and static VAR compensators. Voltage is controlled by switching on capacitors and increasing generator output when system voltage is low and switching off capacitors and switching on reactors when system voltage is high. Usually, the lowest system voltages occur during summer peak conditions when air conditioning load is maximum. Some areas have maximum load conditions during the winter months when resistive heating is maximum. Either way, the highest system voltage conditions usually occur late at night when load is minimum and the lowest system voltage conditions occur in the early evening when load is maximum.

## Generator Dispatch

Generator dispatch is a primary function of day-to-day operations. The units on the system consist of *customer-owned, independent power producers* (merchant plants) or standard utility-owned generation plants. Each has a cost or a contract requirement that must be considered in the dispatch arrangement. The operator plans the day by ensuring that the lowest-cost units are dispatched to “base load” criteria. Then, higher-cost units are dispatched as the load increases during the period. Other units may be required to “load follow” or for “peaking.” The mix of base load and peaking units

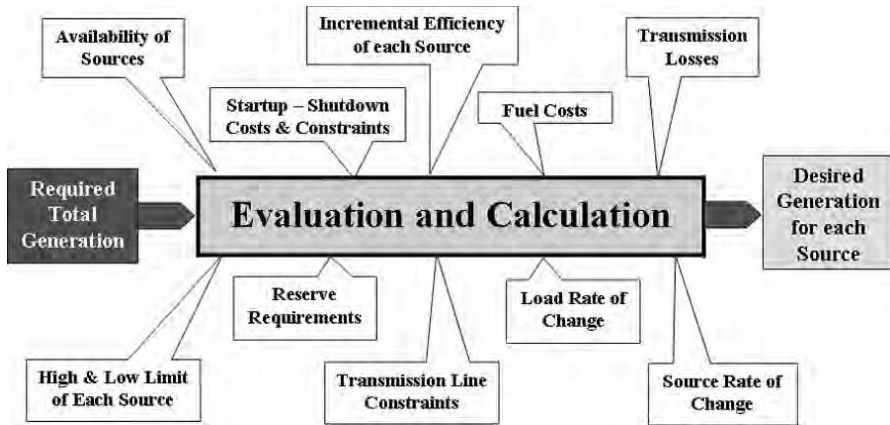

Figure 8-11. Generator dispatch factors.

provides the system operator the resources to effectively and reliably meet system demand with disturbance stability provisions in place.

The *required total generation* is determined by load forecasts plus any other applicable information available that would affect contracts to buy or sell power.

The process of deciding which units to use to meet a daily or weekly requirement is extremely complex. There are many variables that must be considered. To help solve this problem, many utilities use a program called *unit commitment*. The diagram in Figure 8-11 illustrates some of the factors that go into deciding what units should be used to meet a load forecast.

## RELIABLE GRID OPERATIONS

Factors that contribute to reliable grid operations are discussed in this section for both normal and emergency operating conditions.

### Normal Operations

Normal operations occur when all load is being served with stable frequency, proper transmission line flows, ample reserve margins, and little known activity that could suddenly grab the attention of the system operator to take remedial action. In today’s environment, normal means operating several generation units and transmission lines at or near full capacity, trying to

schedule equipment out of service for maintenance, and responding to daily events such as planned outages, switching lines and equipment for maintenance, coordinating new construction projects, and so on.

The behind-the-scenes, day-to-day normal operations will now be discussed.

### ***Frequency Deviation***

Generators are limited to a very narrow operating bandwidth around the 60 Hz frequency. Frequency deviation within an electric system outside these tight parameters will cause generation to trip. Since transmission systems are interconnected to various generation sources, frequency deviation may also trip transmission lines in order to protect other sources of supply.

Frequency deviation must be carefully monitored and corrected immediately. The system operator is watching for the common causes of frequency deviation conditions, such as:

**Sudden Supply/Demand Imbalance.** Loss of supply can reduce frequency.

Loss of load can increase frequency. Either way, frequency deviation is not tolerable and the operator or the automatic generation control system is required to make changes immediately if any event occurs on the system that could jeopardize frequency.

**Short Circuits or Line Faults.** Faults on major transmission lines are usually cleared by opening circuit breakers. Line outages can suddenly add load to another generator and/or suddenly remove load from a generator.

Emergency response during these conditions is often automated, but can also be manually implemented. The system control operator is standing by to take remedial action should an abnormal event occur at any second.

### ***Cascading Failures***

Cascading failure situations may be created by any abnormal condition or system disturbance. They can result in the loss of transmission and/or generation in a cascading sequence. For example, the August 2003 outage that affected most of the Northeastern United States was due to cascading outages. The scenario began by having some transmission and generating facilities in the Northeast out of service for maintenance. Then, one of the remaining transmission lines in service tripped because it sagged into a tree under heavy load conditions. At the time of the trip, major cities in Ohio were in a “heavy” import condition, meaning that much of the energy was being supplied by the transmission interconnection system. Once the first line tripped,

the remaining interconnected transmission system started to overload and one by one several major transmission lines tripped off line.

As the transmission lines began to disconnect, the system experienced sections having excess load and shortage of supply. This created a frequency deviation and the remaining generation on line began to slow down due to the overload condition. The utilities involved did not have adequate generation reserves on line at the time to meet the demand; therefore, generator units began tripping. As generation tripped, the problem continued to worsen.

Each system at the time of the initial failure had some time and opportunity to *island* (i.e., separate from the grid) once the supply was inadequate to meet the load. This time frame for the control operators was probably less than a minute. In that time frame, if the utility did not “disconnect” from the grid and was not able to meet internal load with reserves or through an operational underfrequency load-shedding scheme, the utility remained on the grid and the cascading failures continued.

Eventually, the entire grid was left with no supply. Only those systems that disconnected were able to survive, at least partially, the cascading failure scenario. Unfortunately, the U.S. grid has seen an increasing number of these failures over the last several years, due to delays in building more power plants and transmission lines. Cascading failures can be prevented. The following changes can improve system reliability to reduce the possibilities of future cascading disturbances.

**CONSTRUCTION OF NEW RESOURCES.** As the need for more electrical energy increases and as a result of restructuring, adequate resources in the form of additional transmission lines and generation have not kept pace. This has resulted in lower and lower reserve margins for many utilities. Building more generation plants and transmission lines will significantly improve system reliability.

**TRANSMISSION RATINGS.** NERC has recently undertaken efforts to rerate transmission facilities and dictate when facilities can be taken out of service. Making sure there is adequate transmission capacity at all times or rating the lines so that import limits are set to maintain system integrity is essential to system stability.

**UNDERFREQUENCY SHED SCHEMES.** Utilities are now required to update these protection schemes to ensure that they are adequate to meet the new load and grid requirements.

**CONTROL OPERATOR TRAINING.** New guidelines and requirements are in place to ensure that operators have continuing education and training to keep pace with changes in system requirements.

### ***Voltage Deviation***

Voltage on a system can deviate and cause system operation problems. Voltage constraints are not as restrictive as frequency constraints. Voltage can be regulated or controlled by generation or other connected equipment such as regulators, capacitors, and reactors. Usually, the equipment served (i.e., load) is less sensitive to voltage fluctuations than frequency. The control operator is watching for any of the following conditions to occur that would cause system voltage to deviate substantially:

**Uncontrolled Brownout.** An uncontrolled brownout is a condition in which excessively low voltage is experienced on an electric grid. This condition can persist for long periods of time and can result in equipment failure (i.e., motors or other constant power devices).

**Voltage Surge.** Voltage surges usually result when services are restored and high-voltage transients occur. Voltage surges are usually transient or short term in nature. This type of voltage deviation may damage consumer equipment and possibly lead to other equipment failures.

Normally, utilities are required to maintain voltages within tolerances set by industry standards or regulatory authorities. Manufacturers are expected to design consumer equipment such that it can safely operate within normal power company service tolerances. System operators are responsible for preventing deviations that exceed specified tolerances. System operators are also expected to ensure voltage stability through constant monitoring and adjustment of the system's real-time conditions.

### **Emergency Operations**

Emergency operations exist when the power system is experiencing outages, faults, load shed, adverse weather conditions, and voltage and/or frequency instability. These problems or conditions require the immediate attention of all operating personnel.

Planning and general operating criteria established by regulatory agencies and individual utility companies try to ensure that the system remains stable under a variety of normal and abnormal conditions so that emergency operation can be avoided. Operation of any electric system during abnormal

or emergency conditions requires specially trained and experienced operators. Often, the operator's experience and familiarity with the system capabilities can mean the difference between a small area disturbance and total system shutdown. This section deals with various conditions and typical operating guidelines imposed on operators under emergency operations conditions.

The behind-the-scenes emergency operations will now be discussed.

### **Loss of Generation**

Equipment or other malfunction can cause a generator to trip *offline*. This loss of generation will result in more load than supply until the situation can be resolved. Since electricity is not stored energy, the power system reacts to the difference between generation and load by a change in frequency. The response is immediate and requires corrective reactions within a very short time frame. To compensate for loss of generation, the following planning criteria are in place.

**SPINNING RESERVE.** Spinning reserve, as discussed earlier, provides additional generation *online* and ready to accept load. The typical requirement for spinning reserve is "5–10% of load being served or loss of the single largest contingency." If, for example, the generator that trips is the largest unit on line, the utility should have access to spinning reserves that will compensate for the loss of the unit. However, putting spinning reserves into play requires some reaction time.

**TRANSMISSION RESERVES.** Transmission reserves can provide instantaneous response to loss of generation. Operators carefully monitor transmission loading conditions and available capacity in the event that transmission reserves are needed.

**EMERGENCY GENERATION.** There are some systems where emergency generation can be started in a short time frame (10 minutes or less). The interim period may be handled by a combination of spinning and transmission reserves. Emergency generation is usually located in substations and is fueled by diesel or another fuel source that can be easily stored.

**CONTROLLED BROWNOUTS.** If the mismatch between generation and load is not too great, it may be possible to compensate by reducing distribution voltages. This condition is called a *controlled brownout*. When this condition occurs, lighting dims slightly (sometimes not noticeable). The reduced

voltage results in less power being consumed by resistive loads (such as electric heaters, incandescent lights, and other resistive residential or business loads).

**ROLLING OUTAGES.** If there is a lack of spinning reserve and transmission capability, and if the utility cannot bring supply up to meet load quickly, load shedding is the only option available to ensure that the system remains stable. This approach is typically referred to as a *rolling blackout*, or just a *blackout*, in which operators trip and close substation distribution breakers. Underfrequency-protective relays automatically trip distribution breakers during underfrequency conditions. However, operator intervention of load-shed breaker tripping allows frequency to remain stable before the underfrequency relays start automatically tripping load. This approach is usually a last resort as it does result in loss of revenue and lower customer satisfaction.

Loss of generation and the resulting emergency operation are dependant on the utility's generation and transmission resources. A utility is highly dependant on generation and is susceptible to constraints for the loss of a unit. A utility that has the majority of its energy provided by purchases from other utilities over transmission interties usually experiences less chance of losing its own generating units. However, it is more dependent on system disturbances and uncontrollable events outside its system.

The reliability criterion established by NERC requires that the utility or controlling party adjust system parameters within 10 minutes after a loss of generation in order to prepare for the next-largest contingency. Ten minutes is not much time because another event (such as another relay operation) could occur in the meantime.

### ***Loss of Transmission Sources***

Losing a major transmission line due to weather or malfunction is much the same as loss of generation. Since the transmission system delivers energy in both an import and export mode, loss of a transmission line may result in different scenarios.

**EXPORT.** The loss of a major transmission line in export mode results in too much generation for the load being served. Without correction, the system could experience severe overvoltage and/or overfrequency conditions. The overloading of the remaining transmission lines can result in a cascading failure condition.



IMPORT. The loss of a transmission line in the import mode results in an excess of load compared to supply. This scenario is identical to the loss of generation, in which the system frequency decreases. Automatic load-shedding schemes try to balance load with available generation. Outages are possible. As internal generation comes online, load is restored.

Due to increased restrictions on generation, many utilities are dependant on transmission sources to meet growing energy demands. Often, loss of transmission is more serious than the loss of a generator.



---

# 9

---

## SYSTEM CONTROL CENTERS AND TELECOMMUNICATIONS

---

### CHAPTER OBJECTIVES

- ✓ *Explain the importance of electric system control centers*
- ✓ *Discuss the equipment used in system control centers*
- ✓ *Discuss SCADA (Supervisory Control and Data Acquisition)*
- ✓ *Explain what the system operators monitor and control*
- ✓ *Explain how substation equipment is controlled remotely*
- ✓ *Explain what the Energy Management System does*
- ✓ *Describe the software tools used by system operators*
- ✓ *Describe the types of telecommunications systems used with SCADA*
- ✓ *Explain why electric power companies are using more and more fiber optics*

### ELECTRIC SYSTEM CONTROL CENTERS

*Electric system control centers (ESCCs) like the one shown in Figure 9-1 operate 24 hours a day, 7 days per week making sure the electric power sys-*

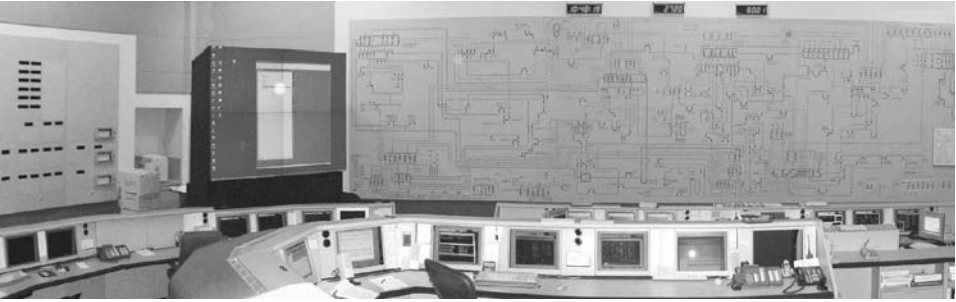

Figure 9-1. Electric system control center.

tem within their control area is operating properly. System operators monitor their control area, looking for signs of possible problems and taking immediate action to avoid major system disturbances should a warning sign occur. Operators are tasked with the responsibility to maintain system connectivity, reliability, stability, and continuous service. They are also responsible for coordinating field crew work activities and making sure crews are safely reported on high-voltage lines and equipment. System control center operators have noteworthy responsibilities.

Under normal conditions, control operators monitor the system and are prepared to respond immediately to incoming alarms from equipment out in the field. Under emergency conditions, control operators respond cautiously to incoming alarms, requests from field personnel, and interagency communications alerts. They realize the complexity of controlling a major system and the possible consequences should they make an error in judgment.

System control operators have many tools at their disposal. These tools help them look ahead to see if something is going to happen and analyze “*what if*” scenarios based on real-time loads and line flows, and they have direct communication lines to people in other strategic locations.

The main tool of the ESCC operator is the *Supervisory Control and Data Acquisition* (SCADA) system. This system allows control operators to monitor, control, and dispatch generation, and obtain written reports of all parameters about the power system. The SCADA system is made up of a centrally located master computer and several *remote terminal units* (RTUs) located throughout the system. An equipment failure or breakdown in the telecommunications equipment supporting SCADA can cause control operators to make incorrect system adjustments. For example, a communications channel between the master computer and a RTU would not update the operators’ information about a substation. The operator would not know if a

breaker were actually open or closed. The lack of up-to-date information is detrimental to the reliable operation of the system, especially during disturbances when critical decisions have to be made.

Telecommunications equipment is used to communicate information electronically between the ESCC and the RTUs. When problems occur in telecommunications equipment or control center equipment, system operators must occupy *back-up control centers* in order to resume monitoring and control functions of the power system. Control centers and back-up control centers normally have emergency generators and *uninterruptible power supply* (UPS) systems to make sure computers, lights, communications equipment, or other critical electric-dependent loads are powered without interruption.

This chapter discusses the equipment used in ESCCs, RTUs, and telecommunications. Upon completion of this chapter, the reader should have a fundamental understanding of what is involved in system control operations.

## **SUPERVISORY CONTROL AND DATA ACQUISITION (SCADA)**

The basic operation of virtually every electric utility in the United States now relies upon *Supervisory Control and Data Acquisition* (SCADA) systems. Up until the late 1940s, many utilities had personnel stationed at substations. In some cases, these were residents who remained on call 24 hours a day. With the advent of SCADA systems, it was no longer necessary for utilities to maintain manned operation of substations. Additionally, utilities need access to system information immediately to properly control the power system.

The basic function of the SCADA system is to remotely control all essential equipment in each substation from a single control center or backup control centers. The functions in the substation that are communicated to the control center are to measure, monitor, and control the substation equipment. At the control center, the basic functions are to display the information, store the information, generate alarms if anything abnormal is detected, and to enable remote control operation of equipment in the substation to initiate changes in the effort to regain normal operation. Also, other equipment not found in substations might have remote-control capability through SCADA, such as backup control centers, transmission line motor-operated switches, emergency load transfer switches, and demand-side management automation.

SCADA systems have the capability of providing graphical representation of the generation stations, transmission lines, substations, and distribution lines. Depending on control area responsibilities, ESCC operators have control of their control areas and responsibilities. They might only be capable of monitoring adjacent interconnected systems.

SCADA alerts a control operator that a change of state occurred. Usually, SCADA gives the operator full control of operating equipment to change the state back to normal. If an operator closes an open breaker via SCADA, for example, then SCADA will in turn alert the dispatcher that the breaker status is now closed. This feedback indication technique is inherent in the SCADA system. This allows operators to verify that actions actually have taken place and the operator can monitor results afterward.

Figure 9-2 outlines the equipment that comprises a SCADA system, including the control center, remote terminal units, and telecommunications equipment. Notice the map board, the main computer, and the various communications systems that connect the RTUs to the main computer.

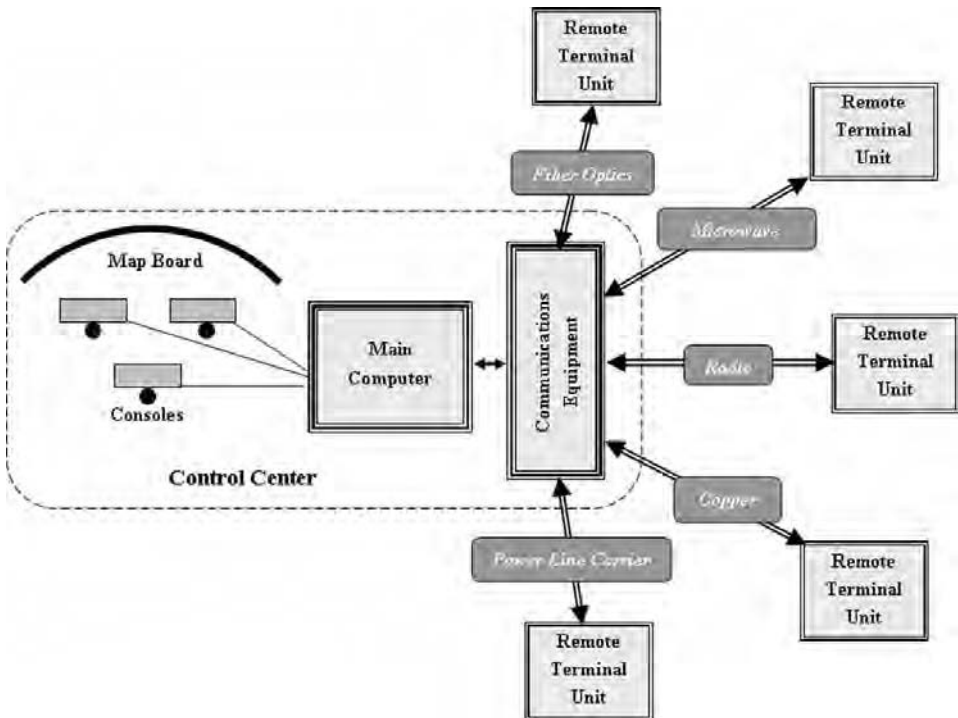

Figure 9-2. SCADA system.

## Data Acquisition Functions

The data acquisition portion of SCADA gives operators the ability to remotely monitor analog electrical quantities such as voltage and current in real time. Also, operators are alerted to problems as they occur through alarm and indication points. For example, tripped breakers, security breaches, fire alarms, enunciator alarms, and so on send signals to the control center where a visual and/or audible alarm attracts the attention of the system operator. The operator then makes changes remotely with the control functions of SCADA.

Some examples of analog data acquisition information include:

- Bus volts
- Transformer watts
- Feeder amps
- System VARs
- Regulator position
- Entry/security alarms

Examples of alarm and indication information include:

- Breaker 1274 now open
- Motor operator switch 577 now closed
- Station service power now off
- Control building door now open

Also, SCADA enables the communication of accumulation data such as the following:

- Generator unit 1 MW-hours
- Generator unit 1 MVAR-hours

## Supervisory Control Functions

The supervisory control portion of SCADA allows operators to remotely control/operate equipment at a particular substation such as:

- Close breaker 1274
- Open motor operator switch 577

- Start emergency generator
- Circuit breakers

## ENERGY MANAGEMENT SYSTEMS

*Energy Management Systems* (EMS) became a major extension from SCADA with the arrival of advanced computer programs and applications. Sophisticated computer programs were developed to monitor system conditions in real time and initiate automatic programmed control responses to operate actual equipment. The perfect example of an automatic power grid function that is controlled by many EMS systems is generation. *Automatic Generation Control* (AGC) is the most comprehensive development of EMS in use today. Smart computer programs are used to ramp up and down generators based on best economics and system reliability factors.

Other very important EMS management computer program tools were developed to improve the reliable operation of large interconnected power grids. These other software tools help reduce power production costs, improve real-time analysis of current system operating conditions, provide information to avoid wrong decision making by operators, improve system reliability and security, and much more. The umbrella term used to describe all these important system operation software tools is now known as the *Energy Management System* or *EMS*.

The most significant EMS software programs in use today are described below.

### State Estimation

The state estimator collects all of the power system status and measurement data from the SCADA remotes, calculates all the load flows and critical voltage points in the system, and calibrates them to real-time values that become a very powerful tool for operators. The state estimator uses all available measurements, known facts, and other relevant information to calculate the best possible estimate of the true status (“state”) of the power system. For example, the state estimator is used to calculate new power flow conditions, such as voltages and currents, to help system operators predict “what if” scenarios.

### Contingency Analysis

The reliability software programs in the EMS perform “what if” scenarios to determine worst-case problems that might result if each major line or trans-



former were taken out of service for any reason. The output ranks potential contingencies according to severity and probability of occurrence, and lists what recommended actions should be taken if such an event occurs.

### **Transmission Stability Analysis**

The reliability software runs a series of outage scenarios based on real-time conditions, looking for transmission line loading conditions and other system shortcomings that can push the system close to stability limits. It looks for increasing voltage violations, increasing VAR requirements, and interchange transactions that can cause problems, and reports those results to the system operator or ESCC engineer.

The software also looks for voltage stability issues to avoid low voltage and voltage collapse problems.

### **Dynamic Security Assessment**

To help system operators identify other potential problems, the dynamic security assessment program reports system equipment that is reaching rating threshold conditions in real time. For example, bus voltages approaching overlimit, lines approaching overloading, and so on are reported to the operator. It also takes into consideration thermal constraints and emergency ratings. This helps operators identify potential problems before they happen and helps provide operating margins during emergency conditions.

### **Emergency Load Shedding**

The EMS is capable of shedding load in an emergency. Similar to underfrequency load-shed relays, the EMS can trip the load fed from circuit breakers if the frequency declines. The operator can drop the load quickly and effectively. System operators can coordinate rolling blackouts before the automatic load-shedding relays operate.

### **Power Flow Analysis**

Static information about the systems lines, transformers, and so on is entered into the computer programs regularly. For example, the line resistance of a new transmission line to go into service is entered into the EMS database. The EMS then calculates the new power flow conditions. The software can report detailed system information during daily, weekly, monthly,

and yearly peak conditions. This power flow data is very useful to planning engineers to determine future power system additions.

### **Generation Planning, Scheduling, and Control**

The EMS is an effective tool for planning generation needs. This planning software incorporates load forecast information, generation schedules, interchange or tie line exchange schedules, unit maintenance schedules, and unit outage situations to determine the best overall generation implementation plan. Further, based on all these schedules, the automatic generation control (AGC) part of the EMS actually controls the dispatch of generation. System operations, area control error (ACE) and frequency are then monitored according to this schedule to assure system reliability and compliance.

### **Economic Dispatch**

The economic dispatch software allocates available generation resources to achieve optimal area economy. It takes into consideration generator incremental loading costs on an individual generator basis, considers transmission line losses, and factors in reliability constraints.

### **Reactive Power Scheduling**

The EMS has the capability to schedule (usually up to 24 hours ahead) the controllable reactive resources for optimum power flow based on economics, reliability, and security.

### **Dynamic Reserves Analysis**

The EMS can periodically calculate the reserve requirements of the system. For example, spinning, 10 minute, and 30 minute predictions are made for a close look at generation requirements and resources. The program takes into consideration operating circumstances (i.e., largest unit on line and time-frame requirements to make changes) to generate reports and alerts operators and engineers if necessary.

### **Load Profiling and Forecasts**

The EMS software has the ability to produce load forecast reports. For example, next the 2–4 hours on a running basis or next 5 or 7 day forecasts on

an hourly basis can be performed by the EMS. These forecasts take into consideration weather information, history trends, time of day, and all other variables that could affect system loading.

### **Demand-Side Management**

As discussed earlier in Chapter 6, demand-side management (DMS) is used to reduce load during certain on-peak conditions. The control signal used to shed interruptible load usually comes from the EMS. The EMS's DSM program decides when to initiate the broadcast signal that results in load reduction. The conditions for which signal broadcasting are required are programmed into the decision logic of the EMS.

### **Energy Accounting**

Since all the records of sales, purchases, meter readings, and billings are centralized in the EMS database, energy accounting reports are generated for management and the regulatory authorities.

### **Operator Training Simulator**

The EMS has the capability to have a functioning operator training console that can be put into real operation at any time. The training simulator gives power system operators real experience using real system quantities on a real-time basis. However, the actual control points are deactivated for the trainee. Instead, simulator software is used to calculate how the system will respond and this is presented to the trainee.

## **TELECOMMUNICATIONS**

Telecommunications systems play a very important role in the reliable operation of large, interconnected electric power systems. Advanced high-speed data networks are used for SCADA, system protection, remote metering, and corporate data and voice communications. Modern equipment like that shown in Figure 9-3 is used to provide communications services for customer call centers, service center dispatch operations, corporate voice lines, system control center private lines, direct interagency communications circuits, analog modem channels, and other services. Video networks are used for surveillance, video conferencing, and enhanced training programs.



Figure 9-3. Communications equipment.

These electronic communications networks are normally designed, built, and maintained by the electric utility.

These data, voice, and video networks are generally made up of six distinct communications system types, as follows:

1. Fiber optics
2. Microwave
3. Power line carrier
4. Radio
5. Leased telephone circuits
6. Satellite

The fundamentals of each of these communications systems are discussed below.

## **Fiber Optics**

Fiber optic communication systems are being installed on electrical power systems all over the world. They are used for a host of services. The majority of the applications are for electric operations and a considerable amount

of fiber is used for customer products and services. Additionally, fibers are leased to third parties as another source of revenue to the electric company.

Generally speaking, a fiber cable can have as few as 12 fiber strands or as many as 400 plus fiber strands depending on need and cable type. The photo in Figure 9-4 shows overhead optical static wire (i.e., *optical ground wire* OPGW) coiled and terminating in a substation and connected to a nonconductive, all-dielectric fiber cable going into the control building. The photo in Figure 9-5 shows a small piece of OPGW. Note: lightning does not damage the optical fibers because they are made of nonconductive glass. Two sets of 12 fiber strands are contained in the center of this OPGW cable.

A fiber strand is made up of a very small glass core (approximately 8 micrometers in diameter), a glass cladding around the core (approximately 125 micrometers in diameter), and a color-coded acrylic coating around the cladding (approximately 250 micrometers in diameter). The acrylic coating adds identification and protection.

Light pulses are transmitted into one end of the fiber strand core and exit the opposite end of the fiber strand core. The light pulses reflect off the surface interface between the core and the cladding, based on the principle of



Figure 9-4. Substation fiber optics.

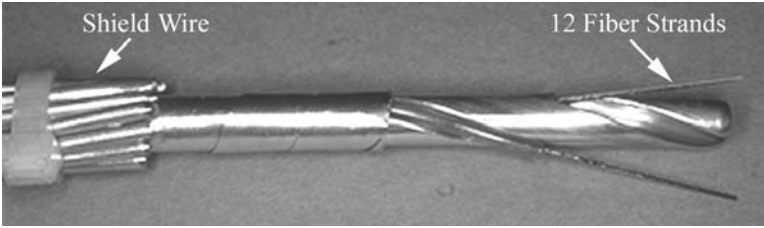

Figure 9-5. OPGW

*reflection of light.* Reflection of light is the principle that allows one to see mountains reflected in calm lakes. The light pulses exit the fiber slightly wider than when they entered the fiber. The longer the fiber is, the wider the output pulse becomes. There is a practical limit as to how often pulses can enter the fiber so that the resulting output pulses do not overlap, thus prohibiting accurate on/off detection. Typically, fiber optic distances reach 100 km without repeaters. Figure 9-6 shows how pulses enter and exit a fiber strand. The light must enter into the core within the aperture angle in order to enable the reflection of light to occur. Sharp bends in the fiber will not let reflection of light to occur.

Electronic on/off digital communications signals are converted into on/off light pulses using a fast-responding laser. The laser is pointed into the core of the fiber. At the receiving end, a very sensitive fast-responding photo detector transforms the optical pulses back into electronic pulses for the communications equipment.

Fiber cable can be wrapped around existing static wires very easily. Many existing transmission lines incorporate fiber wrap technology, mainly on the shield wires as shown in Figure 9-7.

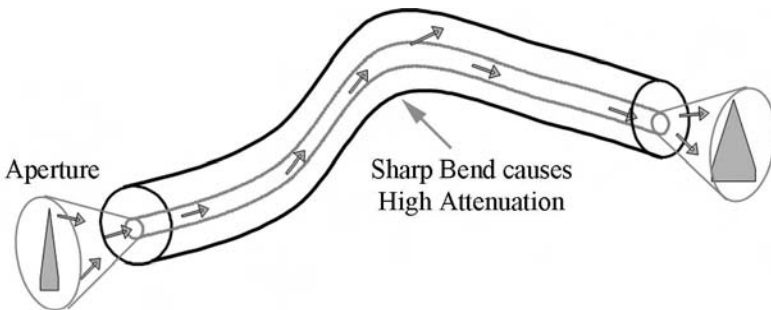

Figure 9-6. Fiber optic principles.

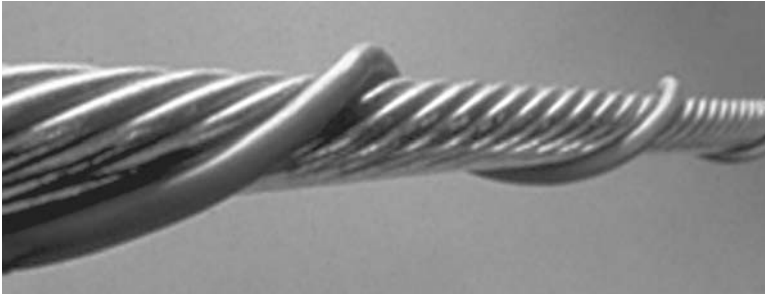

Figure 9-7. Fiber wrap.

A typical fiber cable terminations cabinet in a substation control building is shown in Figure 9-8. Each strand has a fiber connector. Thick jackets are used around each fiber strand for protection.

### Microwave Radio

Microwave (MW) radio communications systems like those shown in Figure 9-9 use special *parabolic-shaped reflector antennas* (called *dishes*) to

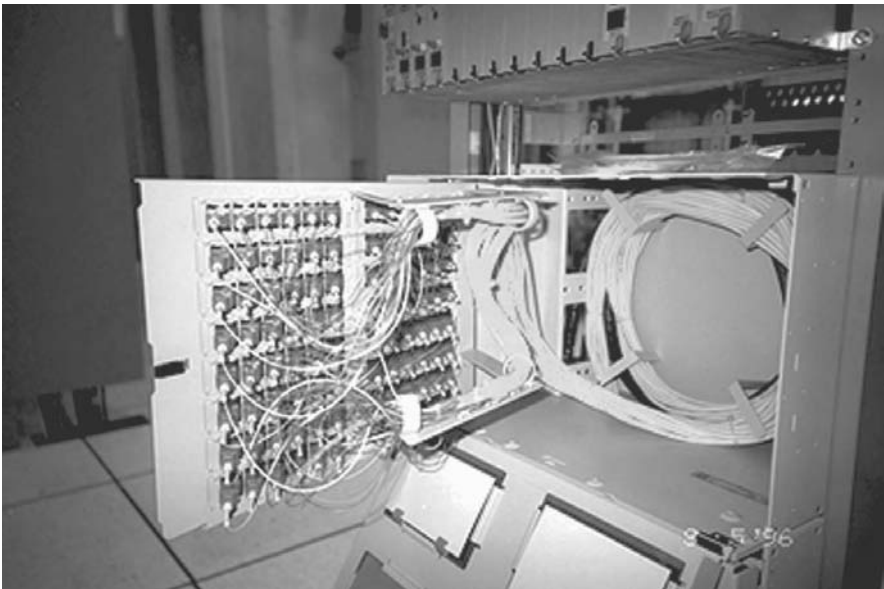

Figure 9-8. Fiber termination.



Figure 9-9. Microwave communications.

reflect radio energy coming out of the *feedhorn* into a beam pointing toward the MW receiver. These super high frequency (SHF) *line of sight radio waves* travel through air at near the speed of light. The receiving antenna at the opposite end of the radio path reflects the energy into another feedhorn where the waveguide transports the radio energy to the communications receiver. The nature of microwave energy enables the use of narrow rectangular waveguides to transport the SHF radio energy between the radio equipment and dish antennas. These point-to-point microwave communications systems can span distances of up to about 100 km without repeaters and can communicate analog or digital data and voice and video signals.

The drawing in Figure 9-10 shows how the SHF radio signals bounce off the reflected dish antennas and travel down waveguides to the radio equipment. The microwave radio at both ends has both receivers and transmitters. The systems operate on two different frequencies so that two-way communication is possible.



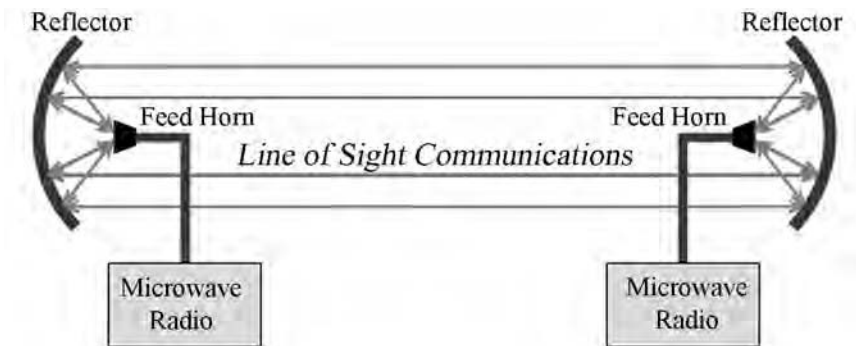

Figure 9-10. Microwave systems.

## Power Line Carrier

Power line carrier (PLC) systems operate by superimposing a high-frequency radio signal onto an existing low-frequency power line. These systems are point to point (i.e., substation to substation). They offer slow data rates compared to fiber or microwave systems. PLC systems like that shown in Figure 9-11 have been in operation for many decades and several systems are still in service today.

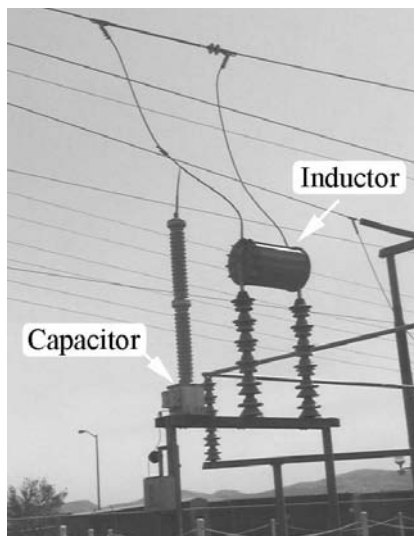

Figure 9-11. Power line carrier.

Referring to Figure 9-12, the theory of operation takes into account the fact that high-frequency radio signals pass easily through capacitors yet are blocked or severely attenuated by inductors or coils, whereas low-frequency signals are just the opposite—they pass through inductors easily yet are blocked by capacitors. The drawing below shows how the equipment is located on a power line inside a substation.

The inductors are sometimes called *line traps* or *wave traps*, and the capacitors are called *coupling capacitors*. Notice that the radio communications occur between the coils and the circuit breakers. Therefore, a line fault that trips the circuit breakers will not disrupt communications (unless the line is cut).

There are a few drawbacks to this older PLC technology, such as transformers that severely attenuate PLC signals, snow and rain weather conditions that can cause high noise levels, and high noise that causes data errors.

### Radio Communications

Point-to-point (P-P) and point-to-multipoint (P-MP) radio communications systems are used by electric utilities for many reasons. P-MP systems are commonly used to provide SCADA data communications services between system control centers and SCADA remote terminal units, usually when fiber optics or microwave radio is too costly. P-MP radio systems are also used as base station systems to communicate with field crews. Portable P-P radio systems are used for voice communications but are quickly being replaced with cellular phone technology systems.

### Copper Communications

Electric utilities use twisted-pair copper communications systems between substations for protective relaying applications.

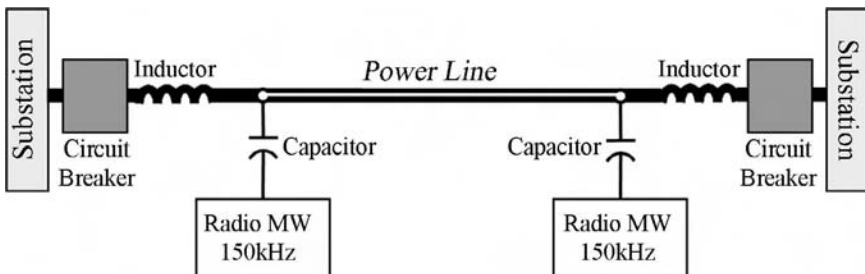

Figure 9-12. PLC System.

There are basically two ownership scenarios involved in copper communications systems: the utility can own the copper cables or the copper circuits can be leased from a third party such as the local telephone company. Leased circuits are used when there are low-priority applications such as voice, remote metering, and interruptible load control, whereas leased circuits are not normally used for high-reliability data circuits such as SCADA or system protection. Electric utilities prefer using privately owned in-house copper cable circuits for critical data communications since they have full control of maintenance and reliability issues.

### **Satellite Communications**

Satellite communications are used in electric power systems for applications that can tolerate 2 second delay times. For example, meter reading and remote information monitoring work well with satellite communications. High-speed protective relaying applications do not work well with satellite communications because the inherent time delay is intolerable. Also, satellite voice communications have pauses that degrade quality of service.

Most electric control center telecommunications systems consist of the different components described above.



## PERSONAL PROTECTION (SAFETY)

---

### CHAPTER OBJECTIVES

- ✓ Discuss “personal protection” in the context of electric power systems safety
- ✓ Explain human vulnerability to electricity
- ✓ Explain how one can be made safe by “isolation”
- ✓ Explain how one can be safe in a “zone of equipotential”
- ✓ Discuss “ground potential rise”
- ✓ Explain why it is so important to know about “touch” and “step” potentials
- ✓ Discuss how line maintenance is performed safely when lines are “energized” or “deenergized and grounded”
- ✓ Explain what is meant by “switching”
- ✓ Discuss the “safety hazards” around the home

### ELECTRICAL SAFETY

The main issues regarding electrical safety are the invisible nature of hazardous situations and the element of surprise. One has to anticipate, visu-

alize, and plan for the unexpected and follow all the proper safety rules to gain confidence in working around electricity. Those who have experience in electrical safety must still respect and plan for the unexpected. There are several methodologies and various personal protective equipment available that make working conditions around electrical equipment safe. The common methodologies and safety equipment are explained in this chapter. The theories behind those methodologies are also discussed. Having a good fundamental understanding of electrical safety principles is very important and is effective in recognizing and avoiding possible electrical hazards.

## PERSONAL PROTECTION

*Personal protection* refers to the use of proper clothing, insulating rubber goods, or other safety tools that isolate a person from electrical shock. Another form of personal protection is the application of *equipotential* principles, by which everything one comes in contact with is at the same potential. Electrical current cannot flow if equipotential exists. Either way, using insulating personal protection equipment or working in a zone of equipotential are known methods for reliable electrical safety.

### Human Vulnerability to Electrical Current

Before discussing personal protection in greater detail, it is helpful to understand human vulnerability to electrical current. The level of current flowing through the body determines the seriousness of the situation. Note: the focus here is on current flow through the body as opposed to voltage. Yes, a person can touch a voltage and experience a shock, but it is the current flowing through the body that causes problems.

Testing back in the early 1950s showed that a range of about 1–2 milliamps (0.001–0.002 amps) of current flow through the human body is considered the threshold of sensitivity. As little as 16 milliamps (0.016 amps) can cause the loss of muscle control. As little as 23 milliamps (0.023 amps) can cause difficulty breathing, and 50 milliamps can cause severe burning. These current levels are rather small when compared to normal household electrical load. For example, a 60 watt lightbulb draws 500 milliamps of current at full brightness with rated voltage of 120 V.

The residential ground fault circuit interrupter (GFCI), like those used in bathrooms, opens the circuit if the differential current reaches approximately 5.0 milliamps (0.005 amps). The GFCI opens the circuit breaker before dangerous current levels are allowed to flow through the human body. The conclusion is humans are very vulnerable to relatively small electrical currents.

## Principles of “Isolation” Safety

A person can be made safe from electrical hazards through the use of proper rubber isolation products such as gloves, shoes, blankets, and mats. Proper rubber goods allow a person to be isolated from *touch and step potentials* that would otherwise be dangerous. (Note: touch and step potentials are discussed in more detail later in this chapter.) Electric utilities test their rubber goods frequently to insure that safe working conditions are provided.

Rubber glove hot-line maintenance is usually done at distribution voltage levels only. Figure 10-1 shows the cotton inner liners, insulated rubber glove and leather protector glove used in typical live-line maintenance.

Figure 10-2 shows high-voltage insulated boots. Figure 10-3 shows typical high-voltage insulated blankets and mats. Every electric utility has extensive and very detailed safety procedures regarding the proper use of rubber goods and other safety-related tools and equipment. Adherence to these strict safety rules and equipment-testing procedures insures that workers are safe. Further, electric utilities spend generous time training workers to work safely, especially when it comes to live-line activities.



Figure 10-1. Rubber gloves. Courtesy of Alliant Energy.



Figure 10-2. Insulated boots.

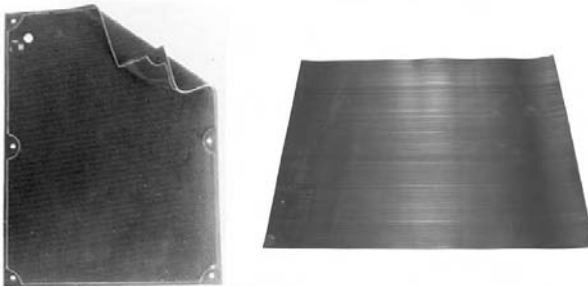

Figure 10-3. Rubber blankets and mats. Courtesy of Alliant Energy.

### Principles of “Equipotential” Safety

Substations are built with a large quantity of bare copper conductors and ground rods connected together and buried about 18–26 inches below the surface. Metal fences, major equipment tanks, structural steel, and all other metal objects requiring an electrical ground reference are all connected to the buried copper conductors. This elaborate interconnected system of conductive metals forms what is referred to as the station *ground grid*.

This elaborate ground grid provides a safe working environment that is sometimes referred to as *equipotential grounding*. Usually, a copper conductor is buried outside the fence perimeter (approximately 3 feet from the fence) to extend the ground grid for additional safety. Usually, 2–4 inches of clean gravel is placed on top of the soil in the substation to serve as additional isolation from current flow and voltage profiles that could exist in the soils during fault conditions. Figure 10-4 shows the ground grid concept.



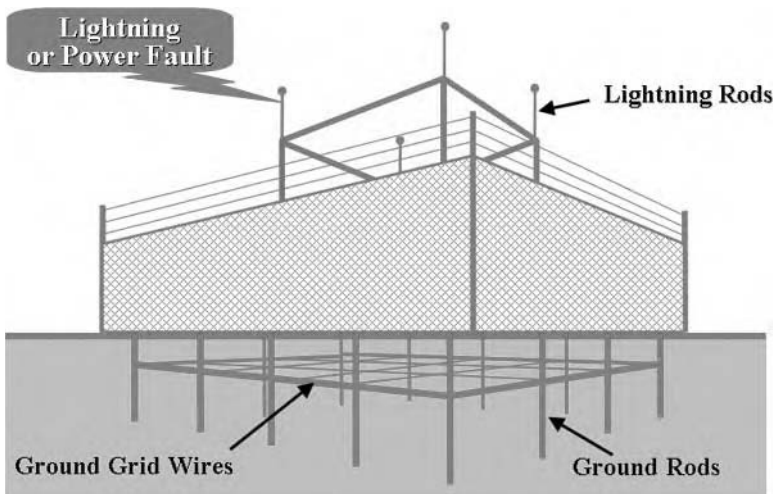

Figure 10-4. Substation ground grids.

There are two main reasons for having an effective grounding system. First, to provide a solid ground path for fault current to flow back to the source in order to trip circuit breakers (i.e., system protection). Second, effective grounds provide a zone of equipotential for safe working environments (i.e., personnel protection). The effective ground grid causes high fault currents to trip circuit breakers faster. The zone of equipotential minimizes the risk of someone experiencing a current flow through during a lightning strike or power fault. Theoretically, everything a person touches in a *zone of equipotential* is at the same voltage and, therefore, no current flows. As an example, suppose you were in an airplane flying above the Earth at 20,000 feet. Everything inside the airplane seems normal. The same is true in a properly designed substation.

## Ground Potential Rise

When a fault occurs on a power system, a *ground potential rise* (GPR) condition occurs in which high electrical currents flow in the ground soils, creating a voltage profile on the Earth's surface. This voltage profile decays exponentially outward from the fault location as shown in Figures 10-5 and 10-6. This GPR condition can cause dangerous *touch* and *step* potentials.

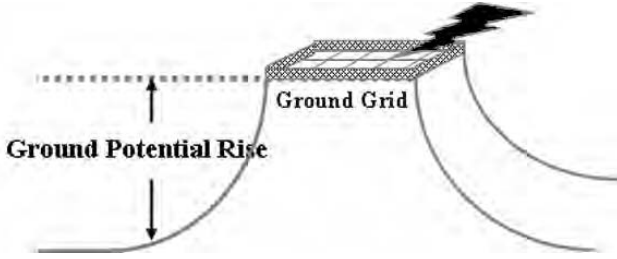

Figure 10-5. Substation ground potential rise.

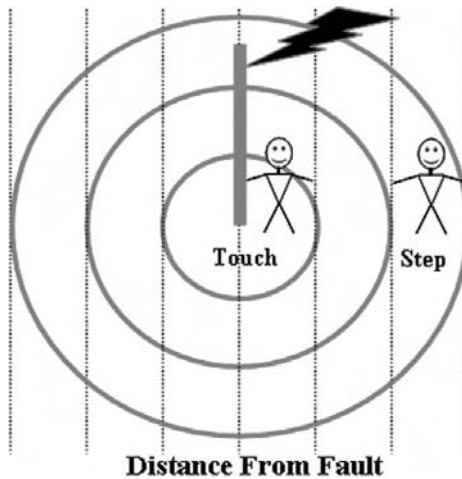

Figure 10-6. Touch and step around structures.

### Touch and Step Potentials

During a lightning strike or power fault event in a substation, the entire substation rises to a high potential and anyone standing on the ground grid during that event should experience no touch or step potential because of the equipotential grounding. *Touch potential* is the difference between the voltage magnitude of a person (or animal) touching an object and the magnitude of voltage at the person's feet. Touch potential can also be the difference in voltage between two potentials (i.e., hand to hand). *Step potential* is the difference in voltage between a person's (or animal's) feet. Shoes, gloves and other articles of clothing help insulate a person from touch and step potentials. Approved, tested, and properly used rubber safety products provide isolation from potentially hazardous touch and step potentials.

## Working Transmission Lines Safely

Construction and maintenance crews work on power lines under energized and deenergized conditions. Either way, special safety precautions are mandatory. All precautions are based on the basic principles of either being fully isolated or in a zone of equipotential conduction. One has to plan on the possibility of a deenergized line becoming energized without notice. Following are examples of different ways to work power lines safely.

### ***Energized Equipment***

There are multiple ways to work on energized power lines safely; insulated bucket trucks, the use of hot sticks, and bare-hand, live-line maintenance are the more common means.

**INSULATED BUCKET TRUCKS.** Working in insulated bucket trucks is a means of working on lines that are either energized or deenergized. Depending on the system voltage being worked on, rubber gloves, fiberglass hot sticks, or live-line, bare-hand methods can be used safely when working out of these trucks. Figure 10-7 shows using an insulated truck.



Figure 10-7. Insulated buckets.

**HOT-STICK, LIVE-LINE MAINTENANCE.** Work can be performed when the lines are energized using hot sticks. Figure 10-8 shows workers using fiberglass *hot sticks* to perform maintenance.

**BARE-HAND, LIVE-LINE MAINTENANCE.** A person can be placed in a conductive suit and safely touch energized transmission voltages as shown in Figure 10-9 as long as they do not come in contact with grounded objects. This is like a bird sitting on the wire. The conductive suit establishes a zone of equipotential and thus eliminates current flow inside the suit or human body. Since everything the person touches is at the same potential, no current flows through the body and the person is safe from electrical shock.

### ***Deenergized and Grounded Equipment***

During deenergized conditions, workers apply ground jumpers to avoid dangerous potentials should the line become accidentally energized. Grounding equipment serves two purposes:

1. Grounding establishes a safe zone of *equipotential*, similar to that in substations. It provides a safe environment against “touch potentials.”



Figure 10-8. Live maintenance on transmission lines.



Figure 10-9. Bare-hand, live-line maintenance.

- 2. Grounding helps trip circuit breakers faster should the line become accidentally energized.

Figure 10-10 shows several jumpers on a rack waiting to be used on a power line or substation that requires them.



Figure 10-10. Ground jumpers.

## Working Distribution Lines Safely

Similar to transmission line work, distribution line crews work under energized or deenergized conditions also. Special safety procedures are mandatory in either situation. Distribution line crews work energized lines (normally under 34 kV) using rubber isolation equipment (i.e., rubber gloves and hot sticks) for voltages less than usually 34 kV. Figure 10-11 shows live line maintenance activities on distribution systems. Working deenergized lines requires “ground jumpers” as discussed above.

## Switching

*Switching* is the term used to change the configuration of the electric system or to provide isolation for safe working activities. Switching is required to open or close disconnect switches, circuit breakers, and for planned maintenance, emergency restoration, load transfer, and equipment isolation. Figure 10-12 shows a switching event in an energized substation. Switching requires careful control of all personnel and equipment involved. This usually requires radio, phone, or visual communication at all times for safety assurance. Detailed radio and equipment *tagging procedures* are also required to help prevent others from interfering with work activities. Switching can be very time-consuming due to the repetitive nature of the communication of the *switching orders*.



Figure 10-11. Live maintenance distribution. Courtesy of Alliant Energy.

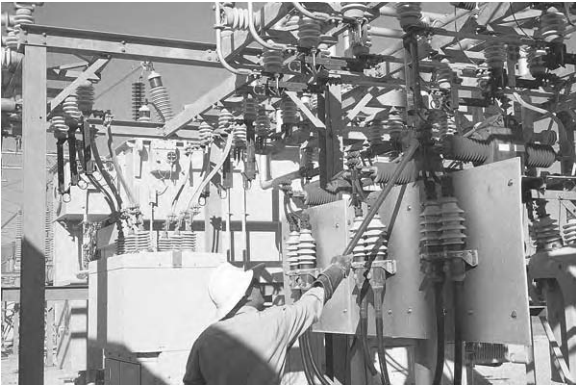

Figure 10-12. Live maintenance substations.



Figure 10-13. Safety hazards at home. Always be vigilant about electrical safety at home!

## **Electrical Safety around the Home**

Home safety also involves the awareness of touch and step potentials. Whether one is exposed to a dangerous touch or step potential in a substation or at home, the same circumstances exist and the same precautions are necessary. As soon as the insulation around energized wires is compromised, dangerous step and touch potentials can exist, even at home. For example, worn extension cords can have exposed conductors that can cause 120 Vac touch potential hazards. All worn cords must be replaced. To compound the problem, water, moisture, metal objects, and faulty equipment can increase the possibility of injury from accidental contact. Figure 10-13 shows how electrical safety hazards can exist at home.



# APPENDIX

---

## APPENDIX A. THE DERIVATION OF ROOT MEAN SQUARED

In order to calculate the equivalent voltage and current in an ac circuit that compares to a dc circuit, the heating effect of each half of the ac sine wave must be found and added together. Since the average value of a complete sine wave is zero, the average value of the positive half of the sine wave must be added to the average value of the negative half of the sine wave. The process of finding the *effective* value of a sine wave is a method called *root mean squared*, or *rms*. The rms value of voltage and current are shown in Figure A-1.

### Residential Voltage

Multiplying the rms value by the square root of two produces what is known as the *peak* value. In the case of residential voltage, the peak value is 165 Vac. Further, multiplying the peak value by 2 results in the term called the *peak-to-peak* value, which is the total measurement of the magnitude of the sine wave as can be seen on an *oscilloscope*. An oscilloscope is a visual voltage measuring device.

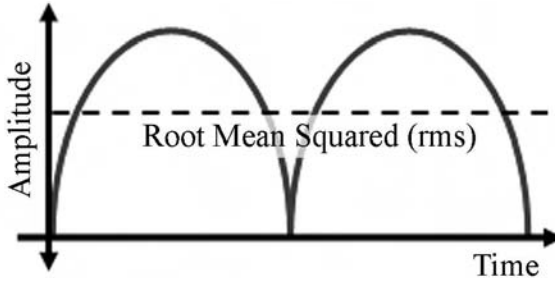

Figure A-1. Root mean squared.

Residential voltage is calculated as follows:

$$V_{rms} = 120 \text{ Vac}$$

$$V_{Peak} = 165 \text{ Vac}$$

$$V_{Peak-Peak} = 330 \text{ Vac}$$

### APPENDIX B. GRAPHICAL POWER FACTOR ANALYSIS

Sometimes, it is easier to see this relationship graphically. Basically, resistors dissipate energy in the form of heat while performing work functions.

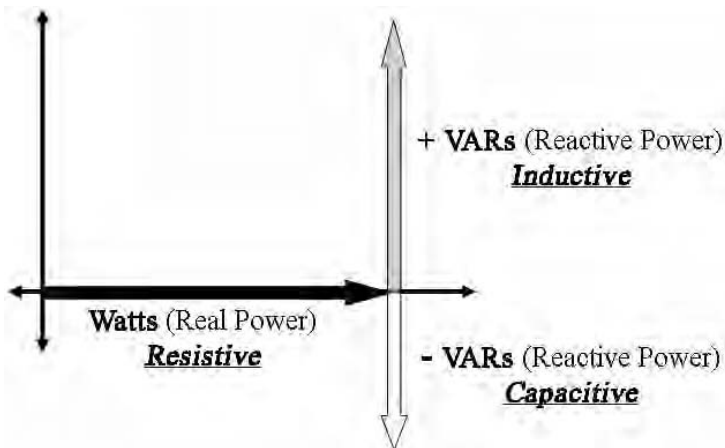

Figure B-1. Electrical power relationships.

The power associated with resistive loads is expressed as *watts*. The power associated with capacitive and inductive loads is expressed as *VARs*. As it is reactive power, the VAR is *wattless* power and does not contribute to real work functions. However, VARs are required in motors, transformers, and most coils to produce magnetic fields in order for the inductive load to function. The total power supplied to an inductive load such as a motor is the watts plus VARs. The interesting factor that exists in ac power systems is that inductive VARs are opposite of capacitive VARs and can cancel each other out if they are of the same value.

The graphical means of showing the relationship between the real and reactive power associated with resistors, inductors, and capacitors is shown in Figure B-1. Note how the inductive and capacitive VARs oppose each other and can cancel, yet resistive watts remain independent.

Figure B-2 shows the power triangle with the capacitive VARs cancelling the inductive VARs. The result is net VARs. In this example, the net VARs are still positive (i.e., the circuit remains inductive). Not all of the inductive VARs were cancelled by capacitive VARs.

The hypotenuse *VA* represents the *total* power; sometimes referred to as the *apparent* power. Total power or apparent power is the *peak voltage* times the *peak current*. Please note that the real part of the VA (watts) is the peak voltage times the current at the time of peak voltage.

The *power factor angle* shown in the graph is the same phase angle shown earlier in Figure 6-2.

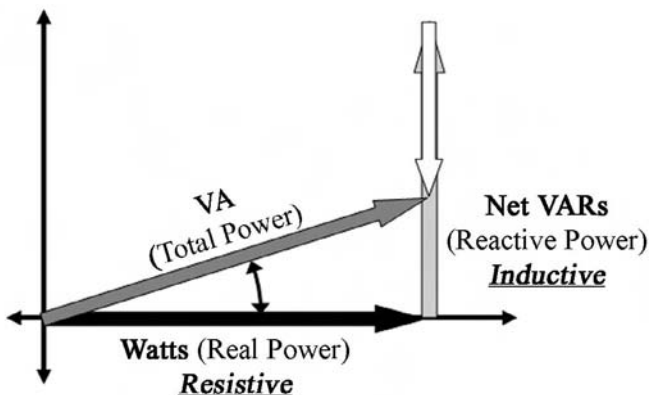

Figure B-2. Power triangle.



# INDEX

- Arc fault interrupter, 152
- Area control error, 185
- Area control error (ACE), 184, 210
- Automatic generation control (AGC), 184, 185, 196, 208, 210
- Baghouse, 25, 26
- Balancing authority, 184, 185, 186
- Base load, 25, 43, 192, 194
- Battery, 2, 5, 6, 8, 18, 46, 80, 98, 158, 162
- Black start, 37
- Blackout, 189, 191, 200, 209
- Boiler feed pump, 24
- Brownout, 198, 199
- Bundling, 48, 49, 50
- Bushing, 66
- Capacitive, 10, 11, 12, 134, 135, 235
- Capacitor, 11, 12
  - bank, 92
  - dielectric, 11, 12
- Cascading failure, 196, 197, 200
- Circuit breaker, 66, 79, 80, 81, 82, 85, 86, 88, 90, 91, 94, 96, 97, 99, 104, 107, 122, 125, 147, 149, 152, 153, 154, 162, 163, 165, 167, 176, 196, 209, 218, 223, 225, 229, 230
- air, 85
- air-blast, 85
- gas, 81, 83, 84
- interrupter, 80, 81
- oil, 80
- power, 80
- sulfur hexafluoride gas, 81
- vacuum, 82
- Combined cycle power plant, 24, 43
- Combustion turbine, 24, 39, 41, 42, 43, 170, 193
- Condenser, 24, 25, 26, 35
- Conductor, 5, 10, 11, 14, 15, 48, 49, 50, 51, 52, 53, 56, 59, 63, 66, 92
  - ACSR, 51, 52, 53
  - American Wire Gauge, 52
  - Circular mils, 52, 53
  - solid, 51, 157
  - stranded, 51, 52
- Control building, 98, 99, 213, 215
- Control center, 93, 146, 157, 180, 185, 203, 204, 205, 206, 207, 211, 218, 219
- Cooling tower, 24, 25
- Current, 2, 3, 5, 6, 7, 8, 9, 10, 11, 12
  - alternating, 2, 3, 8, 9
  - amperes, 5

- Current (*continued*)  
 direct, 2, 8, 9, 45  
 electron flow, 6  
 hole flow, 6
- dc transmission, 57, 58
- Delta, 21, 22, 23, 104, 105, 106, 107, 108,  
 109, 111, 112, 113, 120, 149, 157
- Demand side management, 139
- Dielectric, 11, 57, 66, 80, 81, 82, 85, 95,  
 213
- Disconnect switch, 87, 88, 90, 92, 104, 154,  
 162, 166, 230  
 arcing rod, 88, 89, 90  
 horizontal break, 88  
 horn, 90  
 vertical break, 88  
 whip, 90
- Distribution, 2, 3, 5, 14, 22, 48, 49, 50, 54,  
 55, 61, 62, 64, 73, 74, 76, 78, 79, 86,  
 91, 92, 94, 95, 97, 100, 101, 102,  
 103, 104, 105, 106, 107, 108, 109,  
 110, 111, 113, 114, 116, 118, 120,  
 121, 122, 124, 125, 127, 129, 130,  
 131, 134, 138, 139, 140, 141, 142,  
 144, 145, 147, 149, 162, 165, 166,  
 167, 168, 169, 170, 173, 180, 181,  
 182, 186, 199, 200, 206, 223, 230
- dip pole, 122, 123, 124
- dry-pack transformer, 120
- duplex, 131
- feeders, 76, 104, 105, 109, 167
- fused cutout, 122
- fuses, 80, 107, 121, 122, 162, 167, 168
- industrial consumers, 116, 118, 140, 141,  
 147
- multigrounded neutral, 108, 109
- padmount transformer, 127, 128
- primary, 74, 103, 106, 109, 111, 124,  
 125, 134, 144, 149
- primary neutral, 105, 109, 111, 147
- quadraplex, 131
- radially fed, 167, 170
- riser pole, 123
- secondary, 131
- single-bushing transformer, 107, 116
- three-phase service, 106, 116, 117, 128,  
 131
- three-phase transformer bank, 108, 117,  
 118
- transformer configuration, 113, 118
- triplex, 131
- Distribution line, 22, 48, 50, 55, 62, 74, 79,  
 86, 92, 94, 95, 97, 104, 106, 107,  
 108, 109, 111, 138, 162, 167, 168,  
 169, 173, 206, 230
- Dry steam, 24
- Earth wire; *see* Shield wire
- Economic dispatch, 210
- Edison, Thomas, 2, 54
- Efficiency, 136, 138
- Electrical bus, 92, 93
- Electrical circuit, 5, 8, 12, 138
- Electrical load, 9, 10, 11, 222
- Electrical noise, 153
- Electromagnet, 16, 17, 18, 19
- Electromotive force, 5; *see also* Voltage
- Emergency power, 157
- EMS, 185, 208, 209, 210, 211
- Energy, 2, 3, 5, 7, 8, 11, 19, 20, 22, 23, 24,  
 25, 28  
 import or export, 193  
 watt-hour, 7
- Energy management system, 185, 208; *see  
 also* EMS
- Equipotential, 222, 224, 225, 226, 227,  
 228
- Farad, 12
- Faraday's Law, 14, 15
- Fault current, 79, 86, 95, 97, 161, 165, 168,  
 169, 170, 173, 174, 225
- Federal Energy Regulatory Commission  
 (FERC), 182
- Fiber optics, 212, 213, 218
- Flat frequency control, 185
- Flat tie line control, 185
- Frequency, 8, 9, 15, 19, 20, 24, 26, 59,  
 139
- Generation, 3, 5, 13, 14, 15, 17, 20, 22, 25,  
 29, 33, 35, 38, 39, 43, 45, 62, 94, 95,  
 97, 135, 139, 140, 141, 144, 146,  
 157, 169, 170, 174, 181, 184  
 base load unit, 43, 192

- incremental cost, 192
- load following unit, 192
- load peaking unit, 192
- operating spinning reserve, 193
- prime mover, 19, 20, 22, 23, 175
- spinning reserve, 192, 193, 199, 200
- supplemental reserve, 193
- three-phase ac generator, 15
- three-phase generator, 16, 17, 21, 22
- Generator, 2, 3, 14, 15, 16, 18, 19, 20, 21, 22, 23, 24, 26, 28, 29, 30, 31, 32, 34, 38, 39, 43, 45, 154, 157, 158, 162, 170, 173, 174, 175, 176, 177, 178, 184, 186, 187, 188, 189, 190, 191, 192, 193, 194, 195, 196, 199, 201, 205, 208, 210
- delta, 21
- exciter, 15, 18
- first stage, 24
- rotor, 14, 15, 16
- slip ring, 18
- stator, 14, 15
- three-phase, 15
- three-phase ac, 15
- wye, 21
- Geothermal power, 35, 36
- Geothermal power plants, 34
- Governor, 187
- Ground fault circuit interrupter, 152, 223
- Ground grid, 21, 105, 106, 224, 225, 226
- Ground potential rise, 225, 226
- Grounded, 105
  
- Heat exchanger, 24, 30, 32, 34, 41
- Heat recovery steam generator, 43
- Hemp, 2
- Hertz, 8
- Hydro power plant, 37, 38
  
- Inadvertent power flow, 184
- Independent electricity system operator (IESO), 183
- Independent power producer, 183, 194
- Independent system operator (ISO), 182
- Inductance, 11
  - units (henrys), 11
- Inductive load, 10, 11, 12
- Inertia, 180, 186, 187
  
- Insulation, 2, 48, 49, 53, 54, 55, 56, 66, 91, 100, 103, 107, 120, 124, 129, 131, 152, 155, 232
  - V-string, 48
- Inverter, 46, 158
- Islanding, 180, 184, 197
  
- Kinetic energy, 5, 29
  
- Lagging, 10, 93, 136
- Leading, 10, 12, 136
- Leyden jar, 2
- Lightbulb, 2, 9, 10, 31, 46, 73, 140, 156, 222
- Lightning, 1, 2, 48, 56, 90, 91, 92, 108, 123, 162, 163, 168, 213, 225, 226
- Lightning arrester, 90, 91, 108, 111
  - distribution class, 91, 92
  - Intermediate class, 92
  - metal oxide, 91
  - secondary class, 92
  - station class, 91
- Line charging, 95
- Load, 5, 7, 9, 10, 11, 12, 17, 18, 19, 20, 21, 26, 35, 38, 39, 50, 73, 76, 79, 87, 90, 92
- Load following, 192
- Load shed, 198, 200, 209
- Load tap changer, 74, 76
- Load tap changing transformer, 76, 79
- Load-break elbow, 125, 126, 127
- Lock-out, 86
  
- Magnetic field, 2, 6, 7, 11, 14, 15, 16, 17, 18, 19, 63, 64, 66, 97, 155, 156, 188, 235
  - right-hand rule, 6
- Magnetic pole, 19, 35
- Maintenance, 34, 62, 76, 80, 87, 92, 99, 100, 104, 122, 129, 166, 191, 196, 210, 219, 223, 227, 228, 229, 230, 231
  - condition-based, 99
  - dissolved gas analysis, 99, 100
  - infrared scanning, 99, 100
  - predictive, 62, 99, 100
- Mechanical energy, 19, 175

- Metering, 63, 68, 69, 98, 134, 141, 142, 143, 144, 145, 146, 154, 155, 156, 185, 211, 219
  - demand, 141, 142, 143, 144
  - electric, 141
  - energy, 142, 143
  - power factor, 134, 141, 144, 155
  - primary, 134, 141, 144, 145, 146
  - reactive, 144, 156
  - time of use, 142
- Microwave, 172, 216, 217
  - feedhorn, 216
  - line of sight radio wave, 216
- Microwave radio, 215, 216, 218
- Motor, 2, 7, 11, 14, 20, 21, 38, 56, 73, 77, 88, 92, 93, 94, 118, 120, 134, 135, 138, 140, 154, 155, 156, 157
- Motor load, 120, 134, 156
- Motoring, 175
- Multigrounded neutral, 108
  
- Nameplate, 21, 73
- National Electric Code, 147, 152
- National Electrical Safety Code, 56
- Neutral, 21
- Normal operations, 195
- North American Electric Reliability Corporation (NERC), 180
- Nuclear power, 27, 28, 29, 33, 34
  - boiling water reactor, 32
  - boron, 29
  - containment shell, 29
  - control rod, 29, 30, 31, 32, 33, 34, 88
  - fission, 28, 29, 30, 33
  - fuel assembly, 29
  - fuel tube, 29
  - fusion, 29
  - light water reactor, 29
  - nuclear reaction, 27, 28, 29
  - Nuclear Regulatory Commission, 27, 34
  - pressurized water reactor, 30, 31, 32
  - radiation, 29, 33, 34
  - reactor core, 29, 31, 32, 33, 34
  - SCRAM, 33, 34
- OASIS, 183
- Ohm, 10
- One-line diagram, 166, 167, 170
- Open access, 182, 183
  - Open access same-time information system (OASIS), 183
  - Optical ground wire (OPGW), 213
  - Oscilloscope, 233
  
  - Penstock, 35, 38
  - Performance-based rate, 145, 146
  - Period, 8
  - Permanent magnet, 16
  - Personal protection, 162, 221, 222
  - Phase angle, 135, 136, 144, 157, 176, 235
  - Power, 7
    - negative VAR, 12
    - positive VAR, 11, 12
    - reactive, 11
    - real, 11
    - total, 11
    - volts-amps-reactive (VAR), 11
  - Power factor, 138, 139, 144, 154, 155, 156, 234, 235
  - Power flow, 58, 63, 95, 97, 121, 155, 175, 184, 208, 209, 210
  - Power grid, 3, 56, 97, 146, 180, 181, 186, 187, 189, 208
  - Power line carrier, 172, 217
    - coupling capacitor, 218
    - line trap, 218
  - Power loss, 49, 135
  - Power quality, 39, 58, 155
    - flicker, 156
    - soft starting, 156
    - voltage dips, 156
  - Power system stabilizer, 187
  - Primary underground, 124, 128
  - Protection, 34, 98, 105, 107, 108, 121, 122, 125, 134, 149, 152, 161, 162, 163, 166, 167, 168, 170, 171, 172, 173, 174, 175, 178, 186, 193, 197, 211, 213, 215, 219, 221, 222, 225
    - line-to-ground fault, 107, 173, 174
    - single-phase, 107
  - Protective relay, 34, 63, 68, 69, 79, 80, 85, 86, 98, 104, 157, 161, 162, 163, 165, 166, 170, 174, 200, 218, 219
    - back up clearing, 165
    - differential, 173
    - electromechanical, 34, 142, 162, 163, 164
    - fast trip, 168



- generation protection, 174
- instantaneous, 165, 167, 168, 172, 185, 199
- inverse Current–Time, 163
- lock-out, 86
- minimum pickup setting, 165
- motoring condition, 175
- overcurrent, 86, 167, 168, 169, 174
- overvoltage relay, 174
- permissive relay, 176
- remedial action, 34, 169, 170, 195, 196
- solid state, 163
- synchroscope, 177
- system protection coordination, 165
- time delayed, 172
- transfer trip, 172
- underfrequency, 169, 170, 175, 190, 197, 200, 209
- undervoltage, 174, 175
- zone relay, 170, 172
- Public Service Commission, 145
- Pumped storage hydro power, 38
  
- Reactor, 29, 30, 31, 32, 33, 34, 94, 95, 96, 97, 194, 198
  - series rea, 97
  - shunt rea, 95
- Real time, 139, 167, 186, 207, 208, 209
- Recloser, 85, 86, 87, 162
- Regional reliability council, 183
- Regional Transmission Operator (RTO), 182
- Regulator, 73
  - bandwidth, 73, 77, 78
  - base voltage, 77, 78
  - compensation, 79
  - line reg, 76
  - manual/auto switch, 78
  - reactor coil, 74, 76
  - time delay, 78
- Remote terminal unit, 204, 206, 218
- Residential, 5, 8, 73, 92, 103, 114, 115, 134, 140, 141, 142, 147, 150, 152, 173, 223, 233, 234
- Resistance, 5, 10, 49, 50, 80, 100, 157, 165, 209
- Resistive, 10, 12, 134, 135, 136, 138, 200, 235
  
- Root mean squared, 9, 233, 234
  
- Safety, 56, 87, 104, 105, 125, 149, 152, 162, 221, 222, 223, 224, 227, 230, 232
  - equipotential grounding, 224, 226
  - ground grid, 224
  - ground potential rise, 225
  - home, 232
  - hot sticks, 227, 228, 230
  - insulated blankets and mats, 223
  - personal protection, 221, 222
  - rubber gloves, 125, 162, 223, 227, 230
  - step potential, 223, 225, 226, 232
  - touch potential, 226, 228, 232
  - zone of equipotential, 222, 225, 227, 228
- Satellite communication, 219
- Scale factor, 69
- Scrubber, 25, 26
- Second stage, 24
- Security, 180, 183, 207, 208, 209, 210
- Sequence-of-events recorder, 98, 99
- Service panel, 92, 147, 152
  - main breaker, 149, 158
  - ufur ground, 147
- Shield wire, 56, 214
- Sine wave, 8, 15, 16, 108, 233
- Single-line diagram, 166; *see also* One-line diagram
- Skirts, 67
- Solar power, 35, 37, 45, 46
  - photovoltaic, 45
  - plants, 35
- Source-grounded wye, 106
- Spinning reserve, 192, 193, 199
- Splices, 127
- Stability, 21, 48, 92, 97, 105, 107, 139, 146, 149, 180, 186, 187, 189, 190, 191, 193, 197, 198, 204, 209
- State estimator, 208
- Static VAR compensator, 97, 194
- Static wire, 48, 56, 213, 214; *see also* Shield wire
- Steam, 2, 7, 19, 23, 24, 25, 26, 27, 28, 29, 30, 31, 32, 34, 35, 39, 43, 187, 188
- Steam turbine, 24, 25, 26, 27, 29, 35, 43
  - coal fired, 27
- Steam turbine generator, 24, 27, 43

- Stray current, 106, 108  
 Substation, 3, 22, 51, 56, 61, 62, 73, 74, 76, 80, 86, 87, 88, 91, 92  
 Sulfur hexafluoride (SF<sub>6</sub>) gas, 66, 81  
 Superheated steam, 24, 26  
 Supervisory Control and Data Acquisition (SCADA) system, 204  
 Switching, 25, 56, 94, 96, 97, 98, 104, 124, 162, 166, 194, 196, 230  
 Switching order, 166, 230  
 System protection, 161, 162, 166, 172, 211, 219, 225  
 System voltage, 54, 55, 62, 72, 92, 93, 95, 96, 97, 98, 103, 194, 198, 227; *see also* Voltage
- Tagging procedure, 230  
 Telecommunications, 63, 172, 180, 185, 203, 204, 205, 206, 211, 219  
 Telegraph, 2  
 Telephone, 2, 142  
 Three-line diagram, 166  
 Tie line bias, 185, 192  
 Time error, 186  
 Transformer, 2, 22, 62  
   autotransformer, 72, 73  
   current transformer (CT), 62, 68, 76, 107, 134, 144, 145, 167, 173  
   distribution transformer, 62, 92, 102, 106, 108, 113, 114, 116, 118, 120, 122, 129, 142  
   instrument transformer, 62, 68  
   iron core, 66  
   phase shifting transformer, 63  
   potential transformer (PT), 62, 68, 69, 76, 134, 145, 157  
   regulating transformer, 63  
   step-down transformer, 49, 62, 63, 76  
   step-up transformer, 22, 49, 62
- taps, 69, 73, 74, 76, 78  
   turns ratio, 64, 66, 69, 72, 108, 114, 116, 173  
 Transmission, 3, 14, 47, 55, 57, 58, 59  
   bundled conductor, 49, 50  
   line, 22, 47, 48, 49, 55, 58  
   reserves, 199
- Unbalanced current, 108  
 Underground cable, 54, 124, 125  
 Underground transmission, 57  
 Uninterruptible power supply (UPS), 154, 157, 205  
 Uranium, 28, 29, 33
- Vacuum bottle, 90  
 Voltage, 2, 5  
   alternating, 5  
   category, 55, 103  
   class, 54, 55, 116  
   line, 96  
   line-to-line, 106, 116  
   line-to-neutral, 91, 106, 109  
   lternating, 15  
   nominal, 55  
   phase, 15  
   phase to neutral, 109, 113  
   potential energy, 5, 8  
   stability, 92, 209  
   stability, 105  
   surges, 198
- Watt, James, 7  
 Westinghouse, George, 2  
 Wind generator, 43  
 Wye, 21, 22, 104, 105, 106, 107, 108, 109, 110, 111, 113, 118, 119, 120, 128, 129, 157