



**Course Materials**

**OF**

**BASIC ELECTRICAL  
ENGINEERING  
KEE 101/201**

**Session 2019-20**

**Course Coordinator**

**MR. DIGAMBAR SINGH**

**Course Teachers**

**MS. SURBHI SINGH  
MR. VINOD KUMAR  
MR. DEEPAK JOSHI**



**SYLLABUS**  
**KEE101/201**  
**BASIC ELECTRICAL ENGINEERING**

**Module - 1: DC Circuits** [08] Electrical circuit elements (R, L and C), Concept of active and passive elements, voltage and current sources, concept of linearity and linear network, unilateral and bilateral elements, , Loop and nodal methods of analysis, Star-delta transformation, Superposition theorem, Thevenin theorem, Norton theorem.

**Module - 2: Steady- State Analysis of Single Phase AC Circuits** [10]

Representation of Sinusoidal waveforms – Average and effective values, Form and peak factors, Concept of phasors, phasor representation of sinusoidally varying voltage and current. Analysis of single phase AC Circuits consisting of R, L, C, RL, RC, RLC combinations (Series and Parallel), Apparent, active & reactive power, Power factor, power factor improvement. Concept of Resonance in series & parallel circuits, bandwidth and quality factor. Three phase balanced circuits, voltage and current relations in star and delta connections.

**Module - 3: Transformers** [08] Magnetic materials, BH characteristics, ideal and practical transformer, equivalent circuit, losses in transformers, regulation and efficiency. Auto-transformer and three-phase transformer connections.

**Module -4 : Electrical machines** [08] DC machines: Principle & Construction, Types, EMF equation of generator and torque equation of motor, applications of DC motors (simple numerical problems) Three Phase Induction Motor: Principle & Construction, Types, Slip-torque characteristics, Applications (Numerical problems related to slip only) Single Phase Induction motor: Principle of operation and introduction to methods of starting, applications. Three Phase Synchronous Machines: Principle of operation of alternator and synchronous motor and their applications.

**Module -5 : Electrical Installations** [06] Components of LT Switchgear: Switch Fuse Unit (SFU), MCB, ELCB, MCCB, Types of Wires and Cables, Importance of earthing. Types of Batteries, Important characteristics for Batteries. Elementary calculations for energy consumption and savings, battery backup.



**LECTURE PLAN 2019-20 # BASIC ELECTRICAL ENGINEERING (KEE 201)**

| S. NO. | CONTENT   | CO | LECTURES NO. |
|--------|---|----|--------------|
| 1.     | Electrical circuit elements (R, L and C), Concept of active and passive elements, voltage and current sources   | 1  | 1            |
| 2.     | Concept of linearity and linear network, unilateral and bilateral elements, Loop and nodal methods of analysis  | 1  | 2            |
| 3.     | Star-delta transformation, Superposition theorem, Thevenin theorem, Norton theorem.   | 1  | 2            |
| 4.     | Representation of Sinusoidal waveforms, Average and effective values, Form and peak factors, Concept of phasors   | 2  | 2            |
| 5.     | phasor representation of sinusoidally varying voltage and current. Analysis of single phase AC Circuits consisting of R,L,C,RL,RC,RLC combinations (Series and Parallel)  | 2  | 5            |
| 6      | Apparent, active & reactive power, Power factor, power factor improvement. Concept of Resonance in series & parallel circuits, bandwidth and quality factor. Three phase balanced circuits, voltage and current relations in star and delta connections.      | 2  | 5            |
| 7.     | Magnetic materials, BH characteristics, ideal and practical transformer, equivalent circuit   | 3  | 4            |
| 8.     | Losses in transformers, regulation and efficiency. Auto-transformer and three-phase transformer connections.  | 3  | 5            |
| 9.     | DC machines: Principle & Construction, Types, EMF equation of generator and torque equation of motor, applications of DC motors (simple numerical problems)   | 4  | 7            |
| 10.    | Three Phase Induction Motor: Principle & Construction, Types, Slip-torque characteristics, Applications (Numerical problems related to slip only) Single Phase Induction motor: Principle of operation and introduction to methods of starting, applications. | 4  | 5            |
| 11.    | Three Phase Synchronous Machines: Principle of operation of alternator and synchronous motor and their applications.  | 4  | 2            |
| 12.    | Components of LT Switchgear: Switch Fuse Unit (SFU), MCB, ELCB, MCCB, Types of Wires and Cables, Importance of earthing.  | 5  | 4            |
| 13.    | Types of Batteries, Important characteristics for Batteries.Elementary calculations for energy consumption and savings, battery backup.   | 5  | 2            |



## Module 1: DC Circuits

**Contents:** Electrical circuit elements (R, L and C), Concept of active and passive elements, voltage and current sources, concept of linearity and linear network, unilateral and bilateral elements, Kirchhoff's laws, Loop and nodal methods of analysis, Star-delta transformation, Superposition theorem, Thevenin's theorem, Norton's theorem.

**1. Electrical circuit elements (R, L and C):** The interconnection of various electric elements in a prescribed manner comprises as an electric circuit in order to perform a desired function. The electric elements include controlled and uncontrolled source of energy, resistors, capacitors, inductors, etc. Analysis of electric circuits refers to computations required to determine the unknown quantities such as voltage, current and power associated with one or more elements in the circuit. To contribute to the solution of engineering problems one must acquire the basic knowledge of electric circuit analysis and laws. We shall discuss briefly some of the basic circuit elements and the laws that will help us to develop the background of subject.

**a) Resistor:** Resistor is a dissipative element, which converts electrical energy into heat when the current flows through it in any direction. The law governing the current into and voltage across a resistor is:

$$v = R \cdot i \quad \text{(i)}$$

The relationship is known as Ohm's law.

But resistor can be regarded as linear only within the specified limits, outside which the behavior becomes non-linear. The resistance of a resistor is temperature dependent and rises with temperature.

Mathematically it can be represented as:

$$R_t = R_0(1 + \alpha t) \quad \text{(ii)}$$

Where  $R_0$  = Resistance at  $0^\circ\text{C}$  and  $R_t$  = Resistance at  $t^\circ\text{C}$

$\alpha$  = Temperature coefficient and it may be positive and negative both

$t$  = Temperature in  $^\circ\text{C}$

And power dissipated by resistor is  $p = v \cdot i$

$$p = i^2 R = \frac{v^2}{R} \text{ Watts}$$

Resistor is represented by the symbol



Unit of Resistance is ohm ( $\Omega$ )

**b) Capacitor (C):** It is a two terminal element that has the capability of energy storage in electric field. The law governing the  $v - i$  relationship of capacitor is:

$$i = C \frac{dv}{dt} \quad \text{(iii)}$$

After integrating equation (iii), we get

$$v = \frac{1}{C} \int_0^t i \cdot dt + v_c(0) \quad \text{(iv)}$$



Where  $v_c(0) =$  Capacitor voltage at  $t = 0$ , for initially uncharged capacitor  $v_c(0) = 0$

Hence,  $v = \frac{1}{C} \int_0^t i. dt$  (v)

The above expressions show that the voltage of a capacitor cannot change instantaneously.

Energy stored in capacitor can be represented by

$W = \int p. dt = \int v. i. dt = C \int v. dv = \frac{1}{2} C v^2$  Joule (ix)

Capacitor is represented by the symbol



Unit of Capacitance is Farad (F)

c) **Inductor (L):** It is a two-terminal storage element in which energy is stored in the magnetic field. The  $v - i$  relation of an inductance is:

$v = L \frac{di}{dt}$  (vi)

After integrating expression (vi), we get

$i = \frac{1}{L} \int_0^t v. dt + i_L(0)$  (vii)

Where  $i_L(0) =$  Inductor current at  $t = 0$ , for initially if current through inductor  $i_L(0) = 0$

Hence,  $i = \frac{1}{L} \int_0^t v. dt$  (viii)

The above expressions show that the current through an inductor cannot change instantaneously.

Energy stored in inductor can be represented by

$W = \int p. dt = \int v. i. dt = L \int i. di = \frac{1}{2} L i^2$  Joule (ix)

Inductor is represented by the symbol

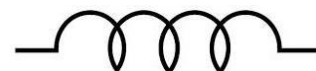

Unit of Inductance is Henry (H)

2. **Concept of active and passive elements:**

**Electrical Network:** Any possible combination of various electric elements (Resistor, Inductor, Capacitor, Voltage source, Current source) connected in any manner what so ever is called an electrical network. We may classify circuit elements in two categories, passive and active elements.

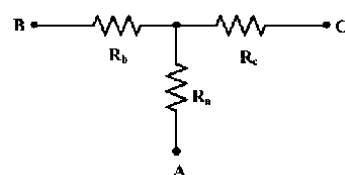

Fig: 1

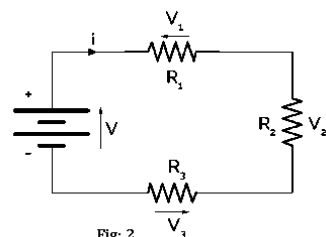

Fig: 2

**Electrical Circuit:** An electric circuit is a closed energized electric network. It



means circuit must have closed path with energy sources. From the above example, we can say that fig 1 and fig 2 are electric networks but only fig 2 is electric circuit.

*It means, electric circuit is always an electric network but electric network may or may not be an electric circuit.*

**Passive Element:** The element which receives energy (or absorbs energy) and then either converts it into heat (R) or stored it in an electric (C) or magnetic (L) field is called passive element, and the network containing these elements without energy sources are known as passive network. Examples are resistor, inductor, capacitor, transformer etc.

**Active Element:** The elements that supply energy to the circuit is called active element and the network containing these sources together with other circuit elements are known as active network. Examples of active elements include voltage and current sources, generators, and electronic devices that require power supplies. A transistor is an active circuit element, meaning that it can amplify power of a signal.

3. **Energy Sources (Voltage and Current Sources):** There are two types of energy sources namely Voltage Sources and Current Sources.

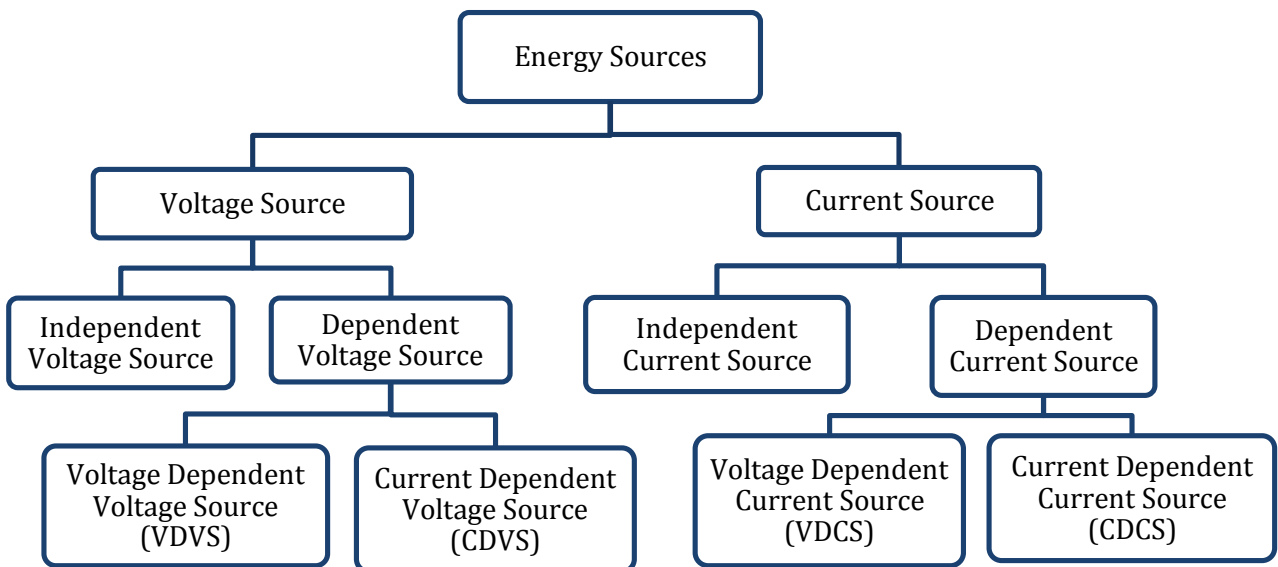

Here, we shall study only about independent voltage source and independent current source.

a) **Independent Voltage Source:** A hypothetical generator which maintains its value of voltage independent of the output current. It can be represented as:

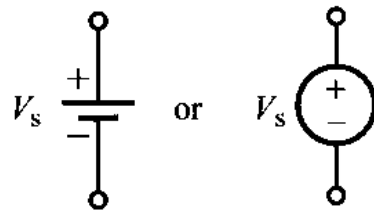

Fig: Ideal DC Voltage Source

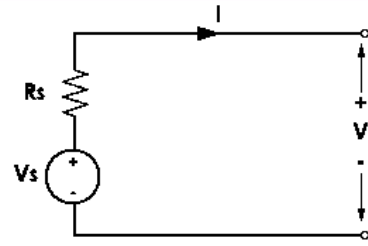

Fig: Practical DC Voltage Source

If the value of internal resistance will be zero, then the voltage source is called as ideal voltage source. The V-I characteristics for ideal and practical voltage source is given below:

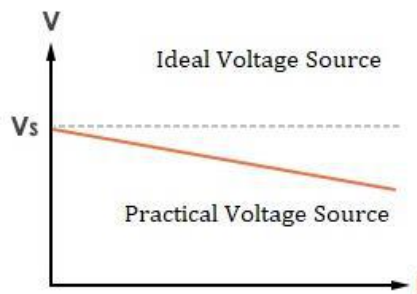

Fig: V-I Characteristic of Voltage Source

**b) Independent Current Source:** A generator which maintains its output current independent of the voltage across its terminals. It can be represented as:

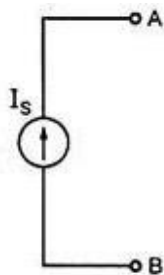

Fig: Ideal DC Current Source

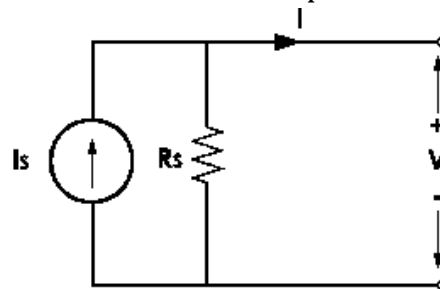

Fig: Practical DC Current Source

if the value of internal resistance will be infinity, then the current source is called as ideal current source. The V-I characteristics for ideal and practical current source is given below:

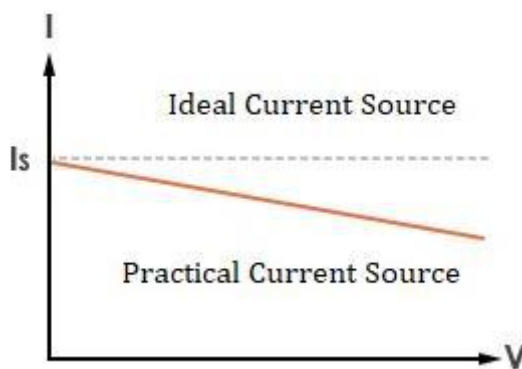

Fig: V-I Characteristic of Current Source



- 4. **Concept of Linearity and Linear Network:** For a network to be linear, it should have to follow the principle of superposition and homogeneity both.

**Principle of Superposition:** An element or circuit obeys the principle of superposition if the net effect of the sum of causes equals the sum of their individual effects.

Mathematically, let cause  $x$  and effect  $y$  be related as:

$$f(x) = y \tag{i}$$

Let the cause be scaled by a factor  $\alpha$ . Then the functional relationship obeys homogeneity, if

$$f(\alpha x) = \alpha f(x) = \alpha y \tag{ii}$$

Consider two causes  $x_1$  and  $x_2$ , then  $f(x_1) = y_1$  and  $f(x_2) = y_2$

Let the combined effect of these two causes be scaled by  $\alpha_1$  and  $\alpha_2$  respectively. The principle of superposition then yields if:

$$f(\alpha_1 x_1 + \alpha_2 x_2) = f(\alpha_1 x_1) + f(\alpha_2 x_2) \tag{iii}$$

If homogeneity is also satisfied, then

$$f(\alpha_1 x_1 + \alpha_2 x_2) = \alpha_1 f(x_1) + \alpha_2 f(x_2) = \alpha_1 y_1 + \alpha_2 y_2 \tag{iv}$$

A functional relationship is said to be linear if it obeys both superposition and homogeneity. Any element governed by such a functional relationship is linear. A circuit composed of such elements would also be linear.

- 5. **Unilateral and Bilateral Elements:**

**Bilateral Elements:** If by reversing the terminal connections of an element in a circuit, the circuit response remains same. Such elements are known as bilateral

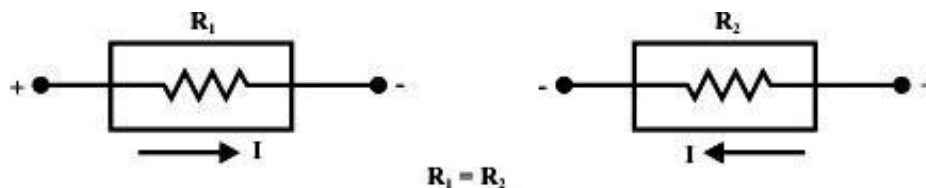

elements. Examples are Resistor, Inductor, Capacitor etc.

**Unilateral Elements:** If by reversing the terminal connections of an element in a circuit, the circuit response gets change. Such elements are called as unilateral elements. Examples are Voltage Source, Current Source, Diode etc.

- 6. **Kirchhoff's laws:** There are two types of Kirchhoff's Law.

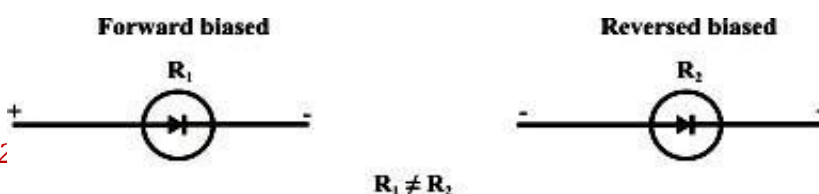





1. Kirchoff's First Law or Kirchoff's Current Law (KCL)
2. Kirchoff's Second Law or Kirchoff's Voltage Law (KVL)

**1. Kirchoff's First Law or Kirchoff's Current Law (KCL):** Kirchoff's current law states that, in a given electric circuit, algebraic sum of all the currents meeting at a junction is always zero. In another way we can say that, the total current flowing towards a junction is equal to the total current flowing away from that junction. This law works on the principle of conservation of charge.

**Sign Convention:** If we take direction of current towards the junction as positive (+) sign then direction of current away from the junction will be taken as negative (-) sign or vice-versa.

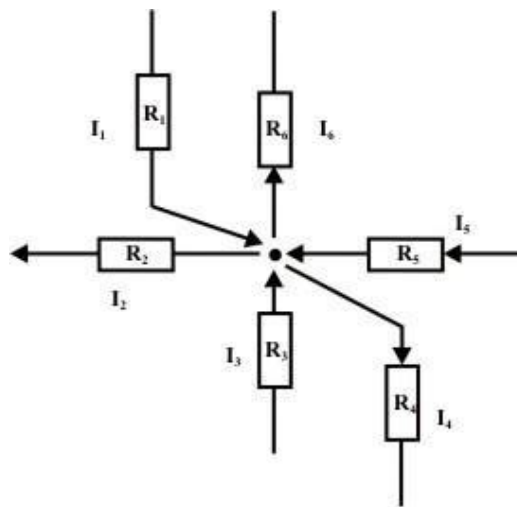

According to Kirchoff's Current Law in the above circuit diagram:

$$I_1 - I_2 + I_3 - I_4 + I_5 - I_6 = 0$$

$$\sum_{i=1}^6 I_i = 0$$

**2. Kirchoff's Second Law or Kirchoff's Voltage Law (KVL):** Kirchoff's voltage law states that, " In any electric circuit, the algebraic sum of the voltage drops across the circuit elements of any closed path (or loop or mesh) is equal to the algebraic sum of the EMFs in the path".

In other words, " The algebraic sum of all the branch voltages around any closed path or closed loop is always zero". This law works on the principle of conservation of energy. Limitation of this law is that it can only be applied to **planar network**.

**Sign Convention:** If we take voltage rise with positive (+) sign then voltage drop will be taken with negative (-) sign or vice-versa. When current direction will be from negative terminal to positive terminal, voltage will rise and vice-versa. In all



*the passive elements current entering terminal is taken as positive and current leaving terminal is taken as negative.*

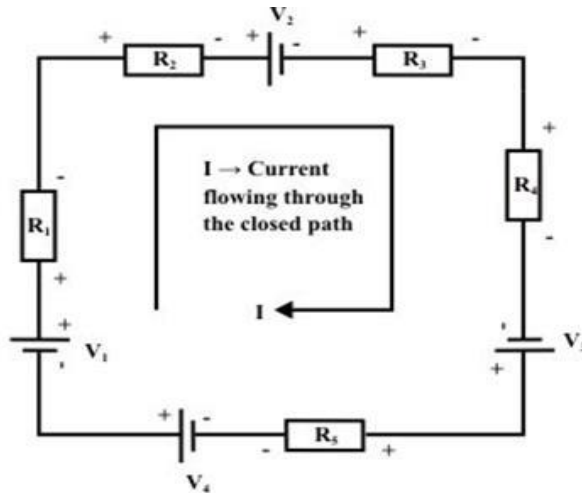

According to KVL in the above circuit diagram:

$$V_1 - IR_1 - IR_2 - V_2 - IR_3 - IR_4 + V_3 - IR_5 + V_4 = 0$$

7. **Loop and Nodal Methods of Analysis:** For study of Loop and Nodal Methods of Analysis, knowledge of basic fundamentals are essential.

**Some Basic Definitions:**

**1. Node:** A node of a network is an equipotential surface at which two or more circuit elements are joined.

**2. Junction:** A junction is that point in an electric circuit where three or more elements are joined.

*So, we can say that junction is always a node but node may or may not be a junction.*

**3. Loop:** A loop is any closed path of the electric network.

**4. Mesh:** A mesh is the most elementary form of loop, and it cannot be further subdivided into other loops.

*So, we can say that mesh is always a loop but loop may or may not be a mesh.*

**5. Lumped Network:** A network in which physically separate resistors, capacitors and inductors can be represented.

**6. Distributed Network:** One in which resistors, capacitors, and inductors cannot be physically separated and individually isolated as separate elements. For example, Transmission Line.

**Loop or Mesh Analysis Method:** Mesh analysis is also known as loop analysis method. Mesh analysis is used to find the currents and voltages in a particular circuit.



Suppose in a particular electrical circuit, total number of branches are  $b$ , total number of nodes are  $n$  and total number of junctions are  $j$ , then total number of meshes 'm' can be calculated by using the following expression:

$$m = b - (n - 1) \quad (i)$$

$$\text{Also, } m = b - (j - 1) \quad (ii)$$

**Note:** One thing make sure, when we consider nodes in the given electric circuit then branches will be counted according to the number of nodes, and equation (i) is used to calculate the total number of meshes. When we consider junction in that electrical circuit then branches will be counted according to junctions, and equation (ii) is used to calculate the total number of meshes. Using both the methods same number of meshes will be found for a particular circuit.

The independent mesh equations can be obtained by applying KVL to each independent mesh.

Mesh current is that current which flows around the perimeter of a mesh. Mesh currents may or may not have a direct identification with branch currents.

Mesh currents on the other hand, are fictitious quantity which are introduced because they allow us to solve problems in terms of a minimum number of unknowns.

### **Procedure of Mesh Analysis Method:**

**Step 1:** Draw the circuit in which mesh currents or branch currents have to find. Calculate number of independent mesh equations by using the formula given below:

$$m = b - (n - 1) \quad (i)$$

$$\text{Also, } m = b - (j - 1) \quad (ii)$$

**Step 2:** Assume independent mesh currents for each mesh. You can choose any direction of the mesh current, but once you have chosen the direction of current, it should remain same throughout the question.

**Step 3:** Apply KVL for each mesh and write the expressions in terms of unknown mesh currents.



**Step 4:** Now, solve the equations by any method, either by simultaneous equation method or Cramer's Rule and find the unknown values.

**Example 1:** Find the current through 'ab-branch' ( $I_{ab}$ ) and voltage ( $V_{cg}$ ) across the current source using Mesh-current method in the given circuit diagram.

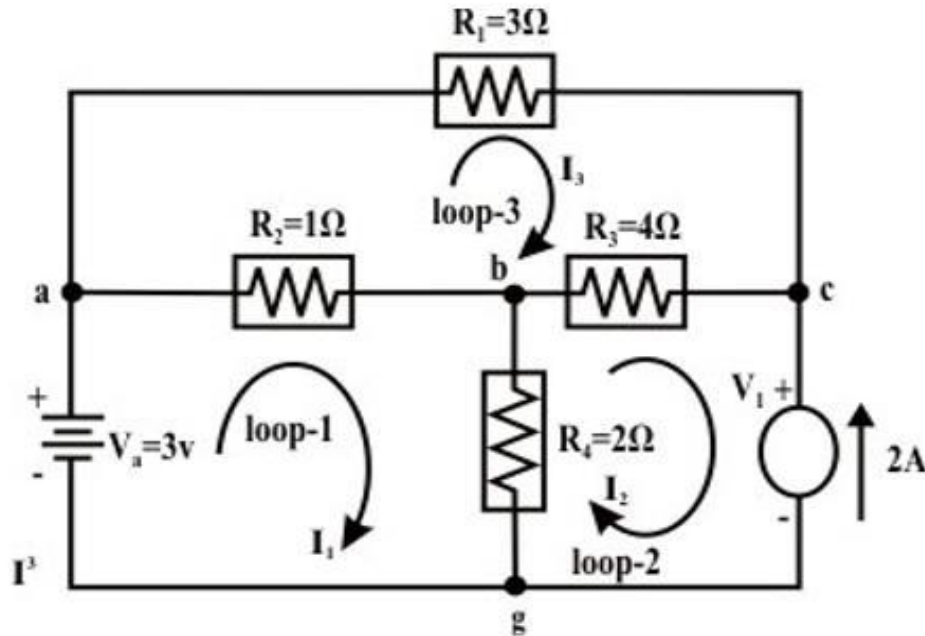

Solution: Assume voltage across the current source is  $v_1$  ('c' is higher potential than 'g' (ground potential and assumed as zero potential) and note  $I_2 = -2A$  (since assigned current direction ( $I_2$ ) is opposite to the source current)

**Loop - 1:** (Applying KVL)

$$V_a - (I_1 - I_3)R_2 - (I_1 - I_2)R_4 = 0 \Rightarrow 3 = 3I_1 - 2I_2 - I_3$$
$$3I_1 - I_3 = -1 \tag{1}$$

**Loop - 2:** (Applying KVL)

Let us assume the voltage across the current source is  $v_1$  and its top end is assigned with a positive sign.

$$-v_1 - (I_2 - I_1)R_4 - (I_2 - I_3)R_3 = 0 \Rightarrow -v_1 = -2I_1 + 6I_2 - 4I_3$$
$$2I_1 + 12 + 4I_3 = v_1 \quad (\text{note: } I_2 = -2A) \tag{2}$$

**Loop - 3:** (Applying KVL)

$$-I_3 R_1 - (I_3 - I_2)R_3 - (I_3 - I_1)R_2 = 0 \Rightarrow -I_1 - 4I_2 + 8I_3 = 0$$
$$I_1 - 8I_3 = 8 \quad (\text{Note, } I_2 = -2A) \tag{3}$$



Solving equations (4.4) and (4.6), we get  $I_1 = -\frac{48}{69} = -0.6956A$  and

$I_3 = -\frac{25}{23} = -1.0869A$ ,  $I_{ab} = I_1 - I_3 = 0.39A$ ,  $I_{bc} = I_2 - I_3 = -0.913A$  and

$I_{bg} = I_1 - I_2 = 1.304A$

- ve sign of current means that the current flows in reverse direction (in our case, the current flows through  $4\Omega$  resistor from 'c' to 'b' point). From equation ( 2), one can get  $v_1 = 6.27$  volt.

Another way:  $-v_1 + v_{bg} + v_{bc} = 0 \Rightarrow v_1 = v_{cg} = 6.27$  volt.

**Nodal Methods of Analysis:** Circuit analysis by this methods are solved by using the KCL at the junction of a particular given circuit.

Suppose, total number of junctions are  $j$  in a particular electrical circuit, then total number of node equations  $N$  can be calculated by using the following formula:

Total number of Node Equations  $N = (j - 1)$  (i)

**Procedure of Nodal Methods of Analysis:**

**Step1:** Draw the electrical circuit in which node voltage or branch currents has to find using this method and calculate the total number of Node equations using the formula:

$$N = (j - 1) \quad (i)$$

**Step 2:** Assume independent node voltages for each junction except reference, because at reference junction voltage will always be zero.

**Step 3:** Apply KCL for each junction except reference.

**Step 4:** Finally solve the equations using different methods.

**Example 2:** Find the value of the current  $I$  flowing through the battery using 'Node voltage' method in the given circuit.

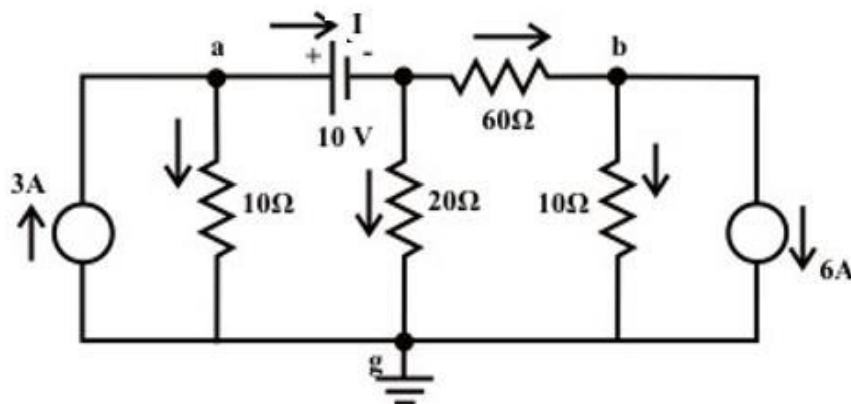



**Solution:** All nodes are indicated in fig. and 'Node-g' is selected as reference voltage. If a voltage source is connected directly between the two nodes, the current flowing through the voltage source cannot be determined directly since the source voltage  $V_S$  is independent of current. Further to note that the source voltage  $V_S$  fixes the voltage between the nodes only. For the present example, the voltage of the central node is known since it is equal to  $(V_a - 10)$  volt.

**KCL equation at node-a:**

$$3 = \frac{V_a - 0}{10} + I \rightarrow 10I + V_a = 30 \quad (1)$$

**KCL equation at node-b:**

$$\frac{(V_a - 10) - V_b}{60} = 6 + \frac{V_b - 0}{10} \rightarrow V_a - 7V_b = 370 \quad (2)$$

To solve the equations (1)-(4), we need one more equation which can be obtained by applying KCL at the central node (note central node voltage is  $(V_a - 10)$ ).

$$I = \frac{V_a - 10}{20} + \frac{(V_a - 10) - V_b}{60} \rightarrow 60I = 4V_a - V_b - 40 \rightarrow I = \frac{(4V_a - V_b - 40)}{60} \quad (3)$$

Substituting the current expression (3) in equation (1) we get,

$$\frac{(4V_a - V_b - 40)}{6} + V_a = 30 \rightarrow 10V_a - V_b = 220 \quad (4)$$

Equations (2) and (4) can be solved to find  $V_b = -50.43V$  and  $V_a = 16.99V$ .

We can now refer to original circuit (fig. ) to find directly the voltage across every element and the current through every element. The value of current flowing through the voltage source can be computed using the equation (3) and it is given by  $I = 1.307A$ .

Note that the current  $I$  (+ve) is entering through the positive terminal of the voltage source and this indicates that the voltage source is absorbing the power, in other words this situation is observed when charging a battery or source.

- 8. Star-Delta transformation:** Certain network configurations cannot be resolved by using series-parallel combinations alone. Such configurations are handled by star-Delta transformations.

**Delta to Star Transformation:**

If we want to transform delta connected network into star connected network, so we will have to calculate the values of star connected resistances in terms of delta connected resistances.

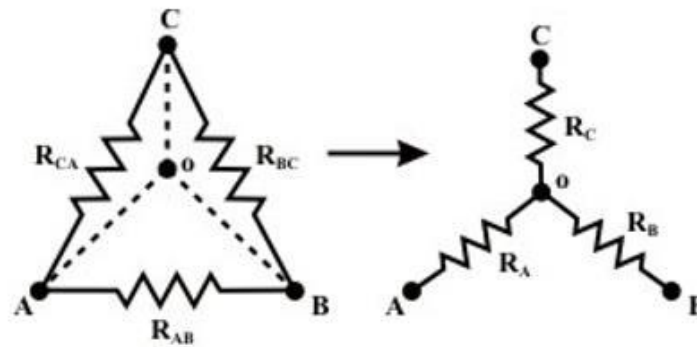

Let us consider the network shown in fig given above and assumed the resistances ( $R_{AB}$ ,  $R_{BC}$ , and  $R_{CA}$ ) in  $\Delta$  network are known. Our problem is to find the values of  $R_A$ ,  $R_B$ , and  $R_C$  in Wye ( $Y$ ) network shown above that will produce the same resistance when measured between similar pairs of terminals. We can write the equivalence resistance between any two terminals in the following form.

**Between  $A$  &  $C$  terminals:**

$$R_A + R_C = \frac{R_{CA} (R_{AB} + R_{BC})}{R_{AB} + R_{BC} + R_{CA}} \quad (1)$$

**Between  $C$  &  $B$  terminals:**

$$R_C + R_B = \frac{R_{BA} (R_{AB} + R_{CA})}{R_{AB} + R_{BC} + R_{CA}} \quad (2)$$

**Between  $B$  &  $A$  terminals:**

$$R_B + R_A = \frac{R_{AB} (R_{CA} + R_{BC})}{R_{AB} + R_{BC} + R_{CA}} \quad (3)$$

By combining above three equations, one can write an expression as given below.

$$R_A + R_B + R_C = \frac{R_{AB}R_{BC} + R_{BC}R_{CA} + R_{CA}R_{AB}}{R_{AB} + R_{BC} + R_{CA}} \quad (4)$$

Subtracting equations (2), (1), and (3) from (4) equations, we can write the express for unknown resistances of Wye ( $Y$ ) network as

$$R_A = \frac{R_{AB}R_{CA}}{R_{AB} + R_{BC} + R_{CA}} \quad (5)$$

$$R_B = \frac{R_{AB}R_{BC}}{R_{AB} + R_{BC} + R_{CA}} \quad (6)$$

$$R_C = \frac{R_{BC}R_{CA}}{R_{AB} + R_{BC} + R_{CA}} \quad (7)$$

**Star to Delta Transformation:**



If we want to transform star connected network into delta connected network, so we will have to calculate the values of delta connected resistances in terms of star connected resistances.

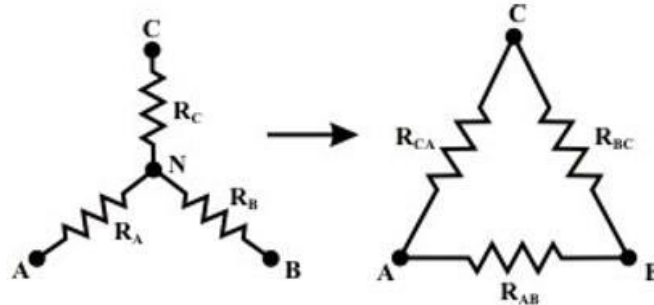

To convert a **Wye (Y)** to a **Delta (Δ)**, the relationships  $R_{AB}$ ,  $R_{BC}$ , and  $R_{CA}$  must be obtained in terms of the **Wye (Y)** resistances  $R_A$ ,  $R_B$ , and  $R_C$  shown in the above figure

Considering the **Y** connected network, we can write the current expression through  $R_A$  resistor as

$$I_A = \frac{(V_A - V_N)}{R_A} \quad (\text{for } Y \text{ network}) \quad (1)$$

Applying KCL at 'N' for **Y** connected network (assume  $A, B, C$  terminals having higher potential than the terminal  $N$ ) we have,

$$\frac{(V_A - V_N)}{R_A} + \frac{(V_B - V_N)}{R_B} + \frac{(V_C - V_N)}{R_C} = 0 \Rightarrow V_N \left( \frac{1}{R_A} + \frac{1}{R_B} + \frac{1}{R_C} \right) = \left( \frac{V_A}{R_A} + \frac{V_B}{R_B} + \frac{V_C}{R_C} \right)$$
$$\text{or, } \Rightarrow V_N = \frac{\left( \frac{V_A}{R_A} + \frac{V_B}{R_B} + \frac{V_C}{R_C} \right)}{\left( \frac{1}{R_A} + \frac{1}{R_B} + \frac{1}{R_C} \right)} \quad (2)$$

For  $\Delta$ -network

Current entering at terminal  $A$  = Current leaving the terminal 'A'

$$I_A = \frac{V_{AB}}{R_{AB}} + \frac{V_{AC}}{R_{AC}} \quad (\text{for } \Delta \text{ network}) \quad (3)$$

From equations (1) and (3),

$$\frac{(V_A - V_N)}{R_A} = \frac{V_{AB}}{R_{AB}} + \frac{V_{AC}}{R_{AC}}$$





Using the  $V_N$  expression in the above equation, we get

$$\left( \frac{V_A - \left( \frac{V_A + V_B + V_C}{R_A + R_B + R_C} \right)}{R_A} \right) = \frac{V_{AB}}{R_{AB}} + \frac{V_{AC}}{R_{AC}} \Rightarrow \left( \frac{\left( \frac{V_A - V_B + V_A - V_C}{R_B + R_C} \right)}{\left( \frac{1}{R_A} + \frac{1}{R_B} + \frac{1}{R_C} \right)} \right) = \frac{V_{AB}}{R_{AB}} + \frac{V_{AC}}{R_{AC}}$$

$$\text{or } \left( \frac{\left( \frac{V_{AB}}{R_B} + \frac{V_{AC}}{R_C} \right)}{\left( \frac{1}{R_A} + \frac{1}{R_B} + \frac{1}{R_C} \right)} \right) = \frac{V_{AB}}{R_{AB}} + \frac{V_{AC}}{R_{AC}} \quad (4)$$

Equating the coefficients of  $V_{AB}$  and  $V_{AC}$  in both sides of eq.(4), we obtained the following relationship.



$$\frac{1}{R_{AB}} = \frac{1}{R_A R_B \left( \frac{1}{R_A} + \frac{1}{R_B} + \frac{1}{R_C} \right)} \Rightarrow R_{AB} = R_A + R_B + \frac{R_A R_B}{R_C} \quad (5)$$

$$\frac{1}{R_{AC}} = \frac{1}{R_A R_C \left( \frac{1}{R_A} + \frac{1}{R_B} + \frac{1}{R_C} \right)} \Rightarrow R_{AC} = R_A + R_C + \frac{R_A R_C}{R_B} \quad (6)$$

Similarly,  $I_B$  for both the networks are given by

$$I_B = \frac{(V_B - V_N)}{R_B} \quad (\text{for } Y \text{ network})$$

$$I_B = \frac{V_{BC}}{R_{BC}} + \frac{V_{BA}}{R_{BA}} \quad (\text{for } \Delta \text{ network})$$

Equating the above two equations and using the value of  $V_N$  (see eq. (2)), we get the final expression as

$$\frac{\left( \frac{V_{BC} + \frac{V_{BA}}{R_A}}{R_C} \right)}{\left( \frac{1}{R_A} + \frac{1}{R_B} + \frac{1}{R_C} \right)} = \frac{V_{BC}}{R_{BC}} + \frac{V_{BA}}{R_{BA}}$$

Equating the coefficient of  $V_{BC}$  in both sides of the above equations we obtain the following relation

$$\frac{1}{R_{BC}} = \frac{1}{R_B R_C \left( \frac{1}{R_A} + \frac{1}{R_B} + \frac{1}{R_C} \right)} \Rightarrow R_{BC} = R_B + R_C + \frac{R_B R_C}{R_A} \quad (7)$$

**9. Network Theorems:** Network theorems are used to solve the electrical circuit problems. There are several types of network theorems, but only three theorems are in this course. These theorems are as follows:

1. Superposition Theorem
2. Thevenin's Theorem
3. Norton's Theorem



**1. Superposition Theorem:** The theorem states that, “ In any multisource complex network consisting of linear, bilateral elements, the voltage across or current through any given element of the network is equal to the algebraic sum of the individual voltage or currents produced independently across or in that element by each source acting independently, when all the remaining sources are replaced by their internal resistances.

**Procedure:** Consider for an electrical network having several independent energy sources are present, so to find the current through a particular branch or voltage across that branch, following steps are used:

**Step 1:** Consider one source at a time and eliminate other sources from the circuit (voltage and current sources are replaced by their respective internal resistances respectively)

**Step 2:** Calculate the current through or voltage across the particular element.

**Step 3:** Repeat the same procedure for all the other energy sources.

**Step 4:** Take the algebraic sum of individual effects produced by individual sources to obtain the total current in or voltage across the element.

**Example 3:** Consider the network shown in given fig. Calculate current ( $I_{ab}$ ) and voltage ( $V_{cg}$ ) using superposition theorem.

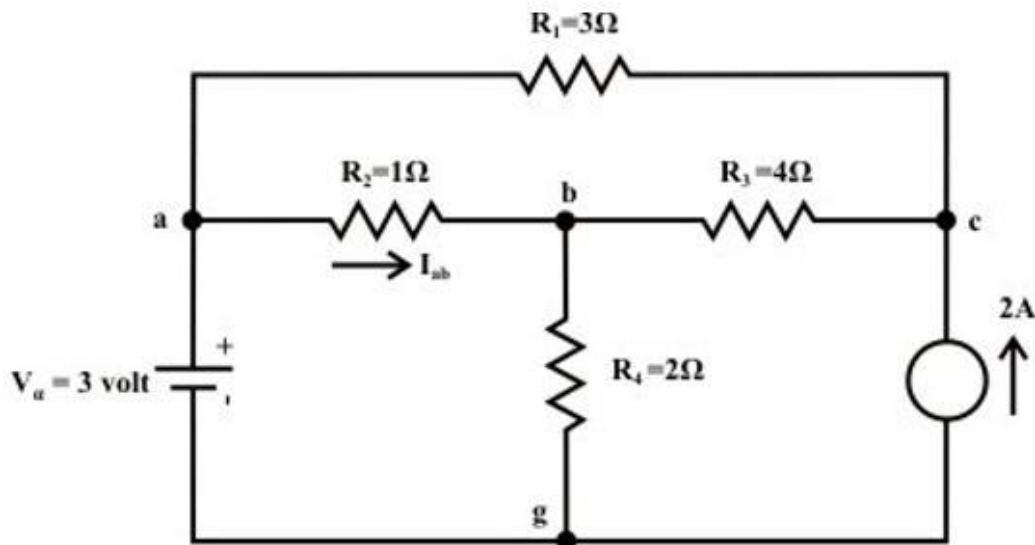



**Solution: Voltage Source Only (retain one source at a time):**

First consider the voltage source  $V_a$  that acts only in the circuit and the current source is replaced by its internal resistance ( in this case internal resistance is infinite ( $\infty$ )). The corresponding circuit diagram is shown in fig. and calculate the current flowing through the 'a-b' branch.

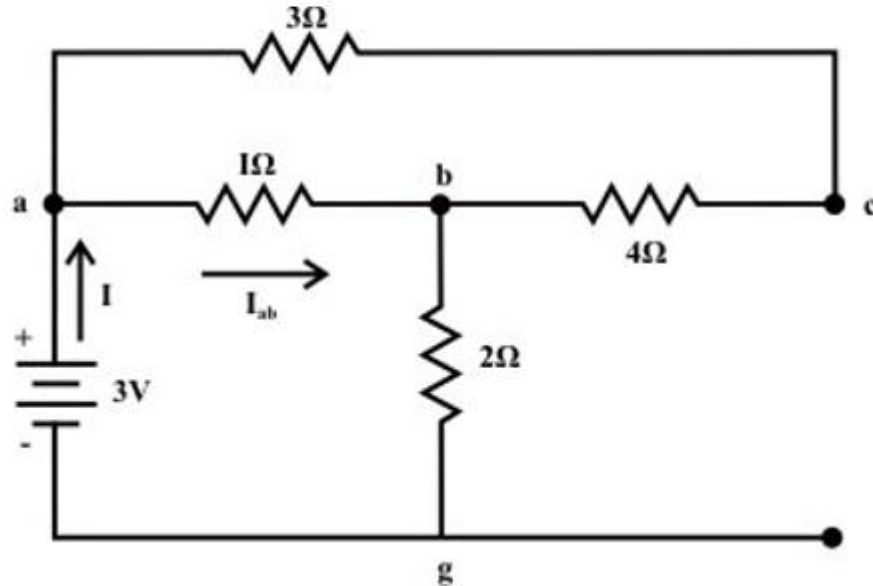

$$R_{eq} = [(R_{ac} + R_{cb}) \parallel R_{ab}] + R_{bg} = \frac{7}{8} + 2 = \frac{23}{8} \Omega$$

$$I = \frac{3}{\frac{23}{8}} A = 1.043A; \quad \text{Now current through a to b, is given by}$$

$$I_{ab} = \frac{7}{8} \times \frac{24}{23} = 0.913A \text{ ( a to b)}$$

$$I_{acb} = 1.043 - 0.913 = 0.13A$$

Voltage across c-g terminal :

$V_{cg} = V_{bg} + V_{cb} = 2 \times 1.043 + 4 \times 0.13 = 2.61 \text{volts}$  (Note: we are moving opposite to the direction of current flow and this indicates there is rise in potential). Note 'c' is higher potential than 'g'.



**Current source only (retain one source at a time):**

Now consider the current source  $I_s = 2A$  only and the voltage source  $V_a$  is replaced by its internal resistance which is zero in the present case. The corresponding the simplified circuit diagram is shown below

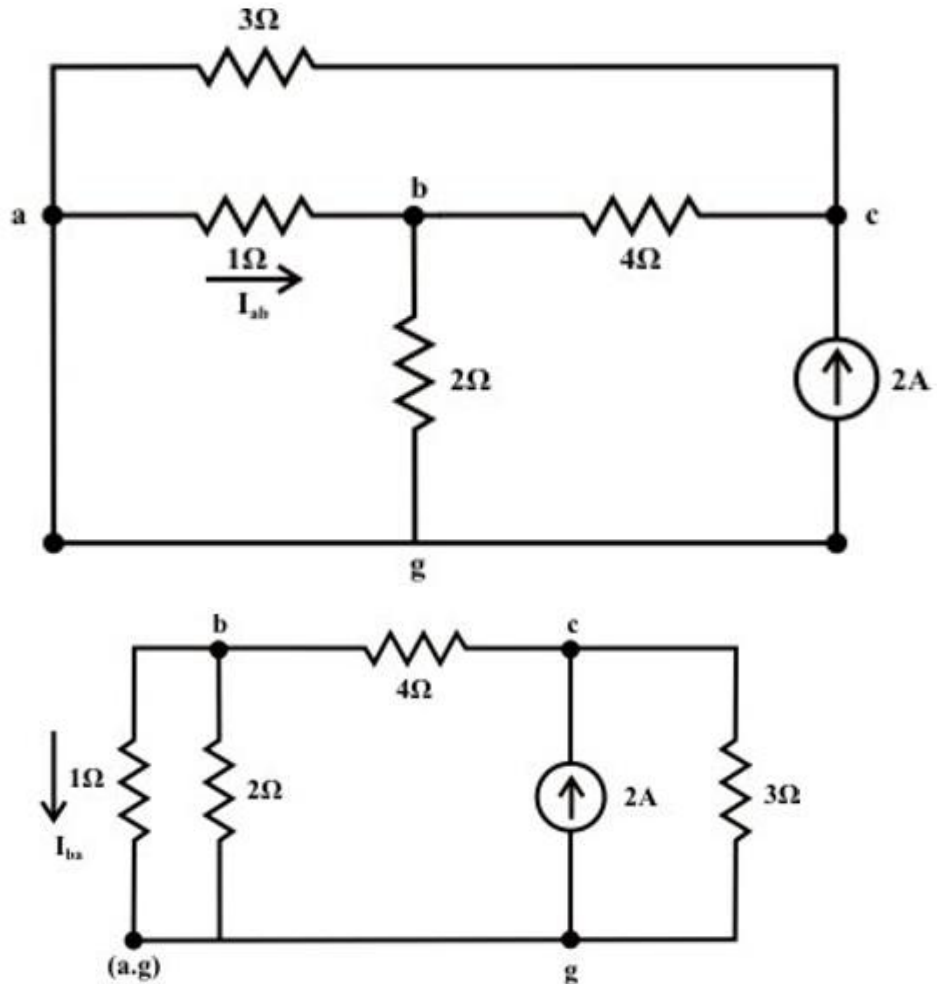



Current in the following branches:

$$3\Omega \text{ resistor} = \frac{(14/3) \times 2}{(14/3) + 3} = 1.217 A; \quad 4\Omega \text{ resistor} = 2 - 1.217 = 0.783 A$$

$$1\Omega \text{ resistor} = \left(\frac{2}{3}\right) \times 0.783 = 0.522 A \text{ (b to a)}$$

$$\text{Voltage across } 3\Omega \text{ resistor (c \& g terminals)} V_{cg} = 1.217 \times 3 = 3.651 \text{ volts}$$

The total current flowing through  $1\Omega$  resistor (due to the both sources) from a to b =  $0.913$  (due to voltage source only; current flowing from 'a' to 'b') –  $0.522$  (due to current source only; current flowing from 'b' to 'a') =  $0.391 A$ .

Total voltage across the current source  $V_{cg} = 2.61 \text{ volt}$  (due to voltage source; 'c' is higher potential than 'g') +  $3.651 \text{ volt}$  (due to current source only; 'c' is higher potential than 'g') =  $6.26 \text{ volt}$ .

**2. Thevenin's Theorem:** This theorem states that, "The current flowing through a load resistance  $R_L$  connected across any two terminals A and B of a linear, active and bilateral network is given by  $V_{oc}/(R_{Th} + R_L)$  where  $V_{oc}$  is the open circuit voltage (i.e. voltage across the two terminals when  $R_L$  is removed) and  $R_{Th}$  is the internal resistance of the network as viewed back into the open circuited network from terminals A and B with all energy sources are replaced by their internal resistances".

**Procedure:** Consider an electrical circuit in which we have to find the current through its  $R_L$  branch. So, step wise procedure is as follows:

**Step 1:** Remove the branch through which current or across which voltage has to find and redraw the circuit.

**Step 2:** Calculation of Thevenin's Resistance ( $R_{Th}$ ) – Remove all the energy sources from the circuit (All energy sources are replaced by their internal resistances) drawn in step 1 and calculate the equivalent resistance of the circuit as viewed back into the open circuited network from terminals A and B.

**Step 3:** Calculation of Thevenin's Voltage ( $V_{oc}$  or  $V_{Th}$ ) – Redraw the circuit of step 1 and find the open circuit voltage by using mesh analysis or any other suitable method.

**Step 4:** Draw Thevenin's equivalent circuit and connect the load resistance across A and B terminals of Thevenin's equivalent circuit.

**Step 5:** Calculate the current flowing through the load resistance using the following formula:

$$I_L = \frac{V_{Th}}{(R_{Th} + R_L)} \quad (i)$$



**Example 4:** For the circuit shown in given fig., find the current  $I_L$  through  $6\ \Omega$  resistor using Thevenin's theorem.

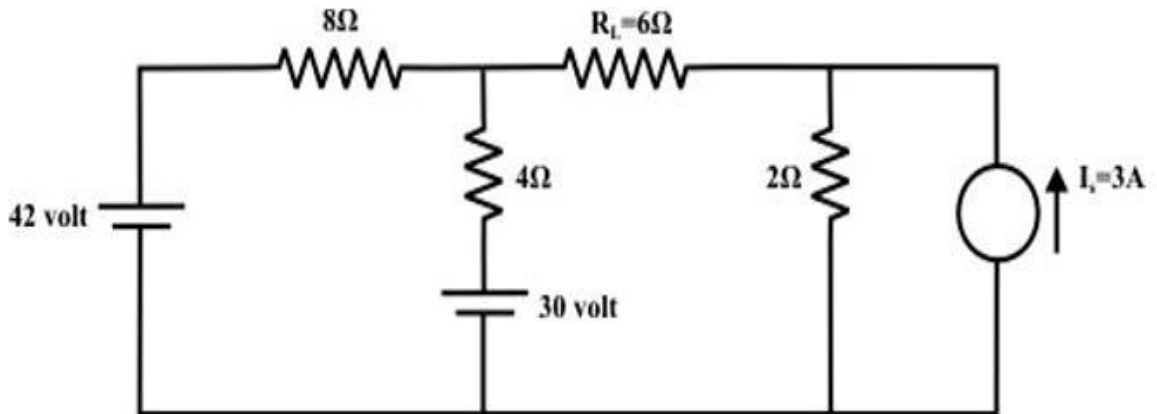

**Solution:**

**Step-1:** Disconnect  $6\ \Omega$  from the terminals 'a' and 'b' and the corresponding circuit diagram is shown in fig. below. Consider point 'g' as ground potential and other voltages are measured with respect to this point.

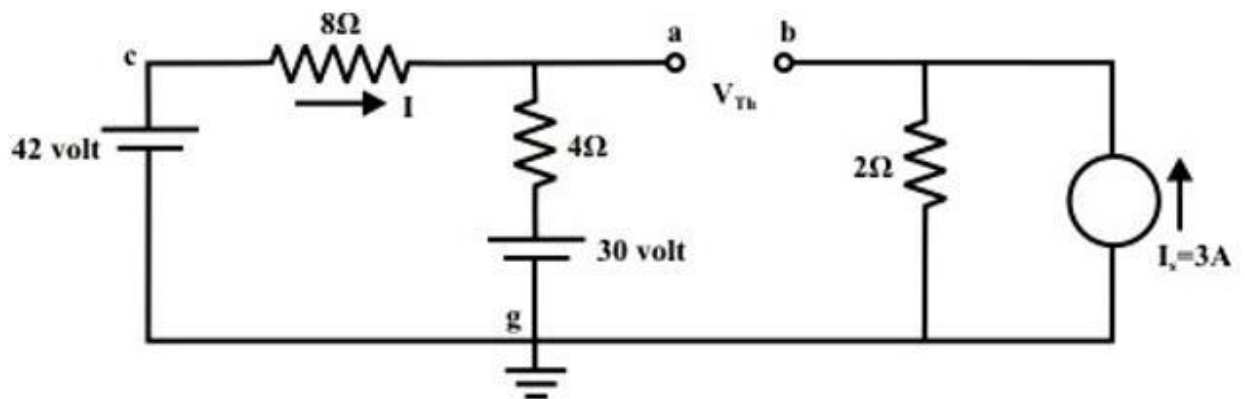

**Step-2:** Apply any suitable method to find the Thevenin's voltage ( $V_{Th}$ ) (or potential between the terminals 'a' and 'b'). KVL is applied around the closed path 'gcag' to compute Thevenin's voltage.

$$42 - 8I - 4I - 30 = 0 \Rightarrow I = 1A$$

$$\text{Now, } V_{ag} = 30 + 4 = 34 \text{ volt; } V_{bg} = 2 \times 3 = 6 \text{ volt.}$$

$$V_{Th} = V_{ab} = V_{ag} - V_{bg} = 34 - 6 = 28 \text{ volt (note 'a' is higher potential than 'b')}$$



**Step-3:** Thevenin's resistance  $R_{Th}$  can be found by replacing all sources by their internal resistances ( all voltage sources are short-circuited and current sources are just removed or open circuited) as shown in fig. below.

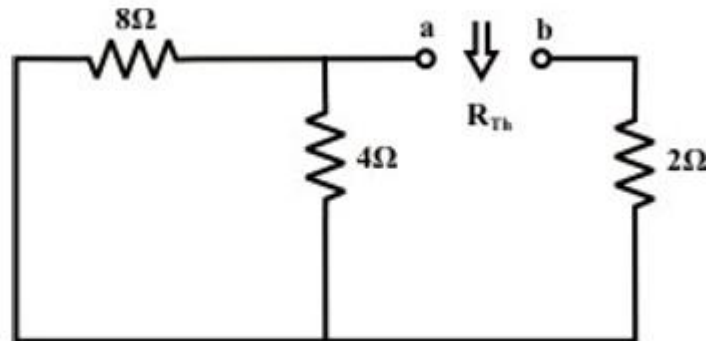

$$R_{Th} = (8 \parallel 4) + 2 = \frac{8 \times 4}{12} + 2 = \frac{14}{3} = 4.666 \Omega$$

**Step-4:** Thevenin's equivalent circuit as shown in fig. below is now equivalently represents the original circuit

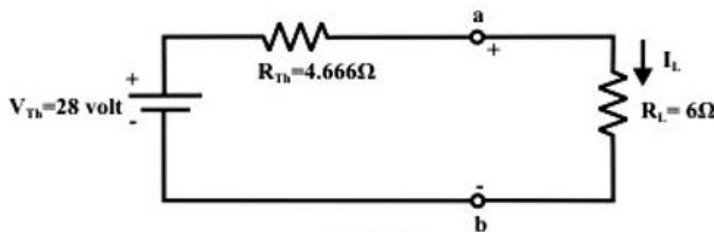

$$I_L = \frac{V_{Th}}{R_{Th} + R_L} = \frac{28}{4.666 + 6} = 2.625 A$$

**3. Norton's Theorem:** This theorem states that, “ Any two terminal active network containing energy sources and resistance when viewed from its output terminals, is equivalent to a constant current source and a parallel resistance. The constant current is equal to the current which would flow in a short circuit placed across the terminals and parallel resistance is the resistance of the network when viewed from these open circuited terminals after all energy sources have been removed and replaced by their internal resistances”.

**Procedure:** Consider an electrical circuit in which we have to find the current through its  $R_L$  branch. So, step wise procedure is as follows:

**Step 1:** Remove the branch through which current or across which voltage has to find and redraw the circuit.

**Step 2:** Calculation of Norton's Resistance ( $R_N$ ) – Remove all the energy sources from the circuit (All energy sources are replaced by their internal resistances)





drawn in step 1 and calculate the equivalent resistance of the circuit as viewed back into the open circuited network from terminals A and B.

**Step 3:** Calculation of Norton's Current ( $I_{sc}$  or  $I_N$ ) – Redraw the circuit of step 1 and find the short circuit current by using mesh analysis or any other suitable method.

**Step 4:** Draw Norton's equivalent circuit and connect the load resistance across A and B terminals of Norton's equivalent circuit.

**Step 5:** Calculate the current flowing through the load resistance using the following formula:

$$I_L = I_N \frac{R_N}{(R_N + R_L)} \quad (i)$$

**Example 5:** For the circuit shown in the given fig., find the current through  $R_L = R_2 = 2\Omega$  resistor ( $I_{a-b}$  branch) using Norton's theorem & hence calculate the voltage across the current source ( $V_{cg}$ ).

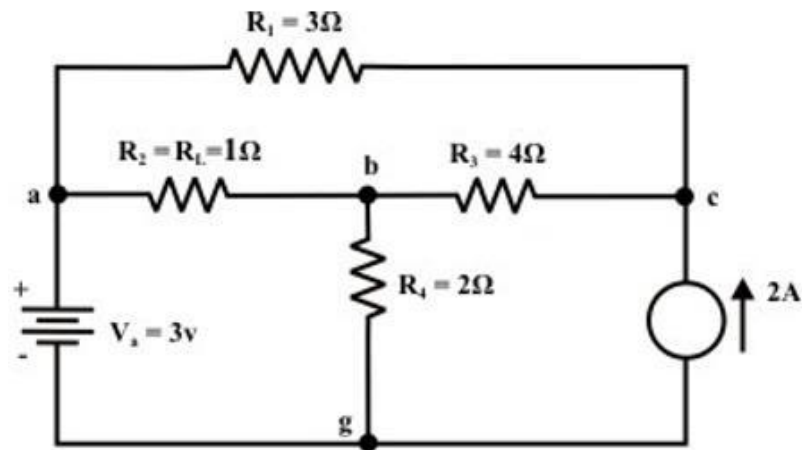

**Solution:**

**Step-1:** Remove the resistor through which the current is to be found and short the terminals 'a' and 'b'

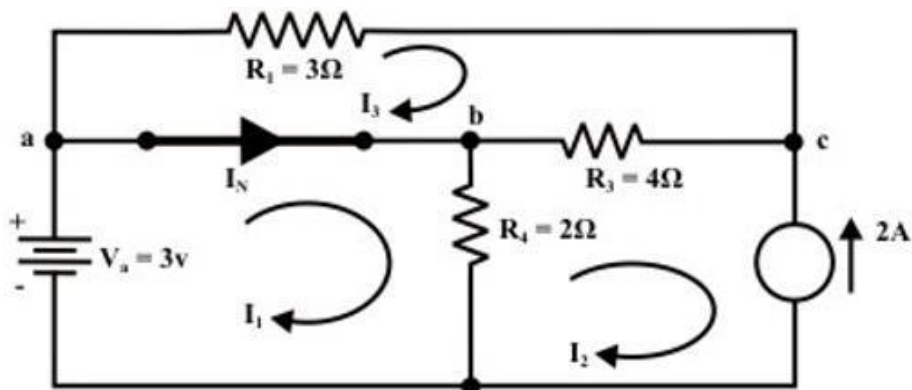



**Step-2:** Any method can be adopted to compute the current flowing through the a-b branch. Here, we apply 'mesh – current' method.

Loop-1

$$3 - R_4(I_1 - I_2) = 0, \text{ where } I_2 = -2A$$

$$R_4 I_1 = 3 + R_4 I_2 = 3 - 2 \times 2 = -1 \quad \therefore I_1 = -0.5A$$

Loop-3

$$-R_1 I_3 - R_3(I_3 - I_2) = 0$$

$$-3I_3 - 4(I_3 + 2) = 0$$

$$-7I_3 - 8 = 0$$

$$I_3 = -\frac{8}{7}$$

$$\begin{aligned} \therefore I_N &= (I_1 - I_3) = \left(-0.5 + \frac{8}{7}\right) = \frac{-7+16}{14} \\ &= \frac{9}{14} \text{ A (current is flowing from 'a' to 'b')} \end{aligned}$$

**Step-3:** To compute  $R_N$ , all sources are replaced with their internal resistances. The equivalent resistance between 'a' and 'b' terminals is same as the value of Thevenin's resistance of the circuit shown in fig. below.

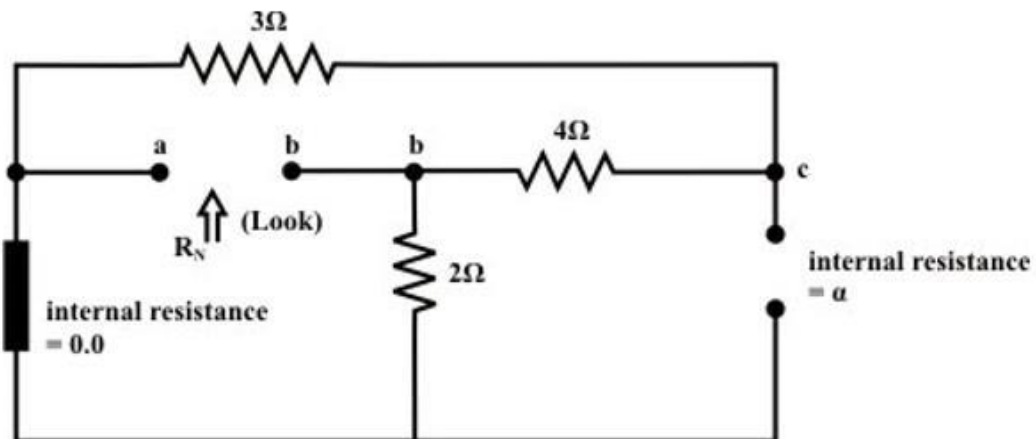



**Step-4:** Replace the original circuit with an equivalent Norton's circuit as shown in fig.

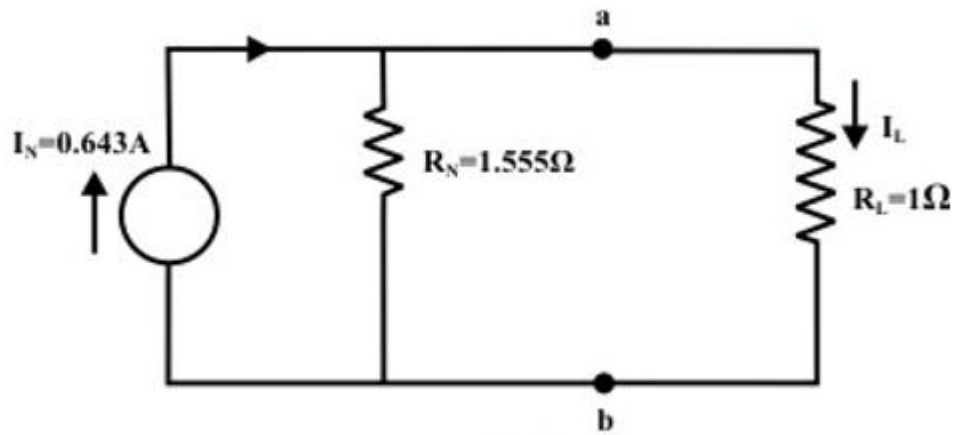

$$I_L = \frac{R_N}{R_N + R_L} \times I_N = \frac{1.555}{1.555 + 1} \times 0.643 = 0.39\text{A (a to b)}$$



---

## Module - 2: Steady- State Analysis of Single Phase AC Circuits:

---

**Contents:** Representation of Sinusoidal waveforms – Average and effective values, Form and peak factors, Concept of phasors, phasor representation of sinusoidally varying voltage and current. Analysis of single phase AC Circuits consisting of R, L, C, RL, RC, RLC combinations (Series and Parallel), Apparent, active & reactive power, Power factor, power factor improvement. Concept of Resonance in series & parallel circuits, bandwidth and quality factor. Three phase balanced circuits, voltage and current relations in star and delta connections.

---

### Average value

The current waveform shown in Fig. 12.3a, is periodic in nature, with time period, T. It is positive for first half cycle, while it is negative for second half cycle.

The average value of the waveform,  $i(t)$  is defined as

$$I_{av} = \frac{\text{Area over half cycle}}{\text{Time period of half cycle}} = \frac{1}{T/2} \int_0^{T/2} i(t) dt = \frac{2}{T} \int_0^{T/2} i(t) dt$$

Please note that, in this case, only half cycle, or half of the time period, is to be used for computing the average value, as the average value of the waveform over full cycle is zero (0).

If the half time period (T/2) is divided into 6 equal time intervals ( $\Delta T$ ),

$$I_{av} = \frac{(i_1 + i_2 + i_3 + \dots + i_6) \Delta T}{6 \cdot \Delta T} = \frac{(i_1 + i_2 + i_3 + \dots + i_6)}{6} = \frac{\text{Area over half cycle}}{\text{Time period of half cycle}}$$

Please note that no. of time intervals is  $n = 6$ .

### Root Mean Square (RMS) value

For this current in half time period subdivided into 6 time intervals as given above, in the resistance R, the average value of energy dissipated is given by

$$\propto \left[ \frac{(i_1^2 + i_2^2 + i_3^2 + \dots + i_6^2)}{6} \right] R$$

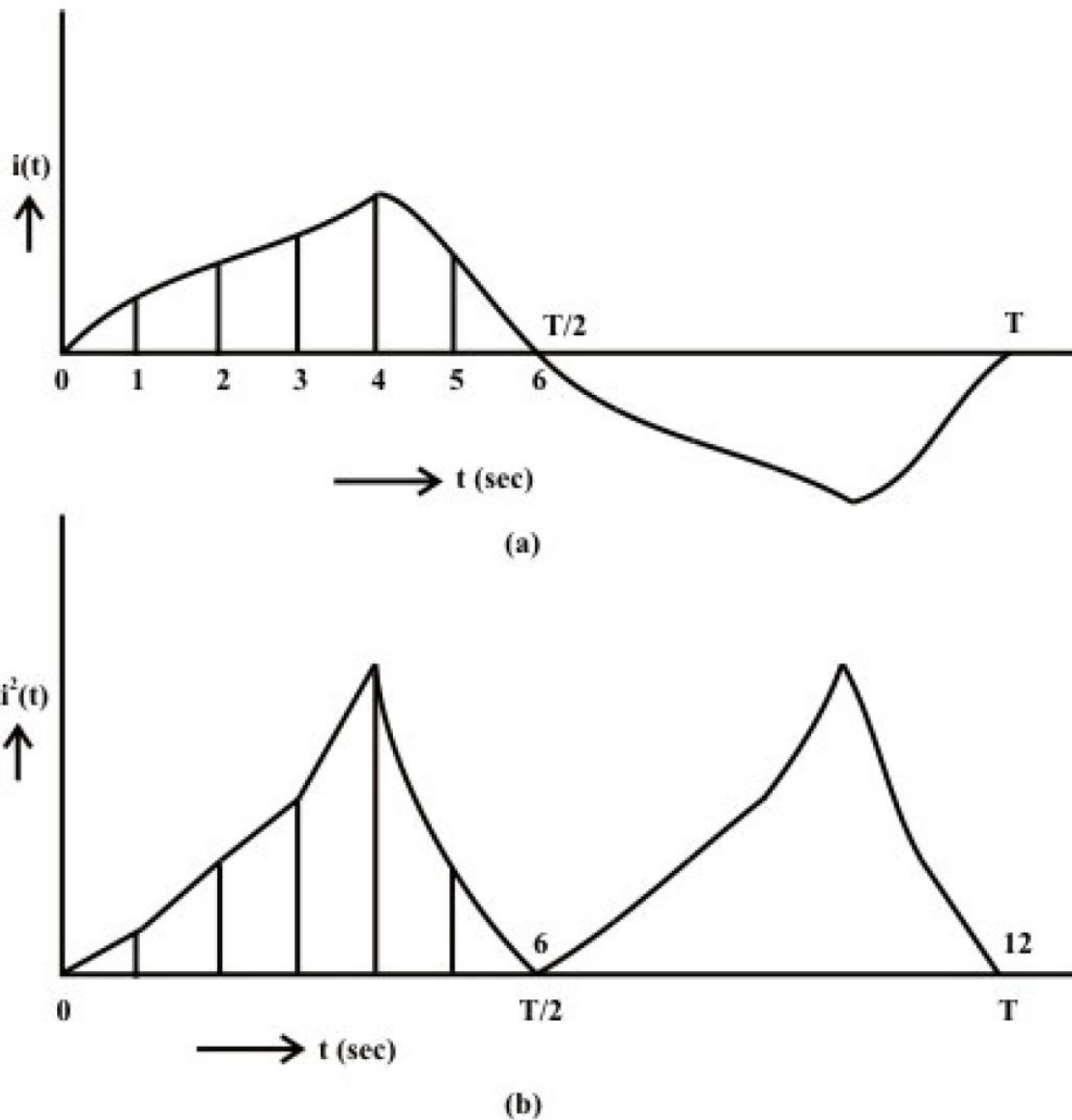

**Fig. 12.3 Periodic current waveform  
(a) Current (i), (b) Square of current ( $i^2$ )**

The graph of the square of the current waveform,  $i^2(t)$  is shown in Fig. 12.3b. Let  $I$  be the value of the direct current that produces the same energy dissipated in the resistance  $R$ , as produced by the periodic waveform with half time period subdivided into  $n$  time intervals,

$$I^2 R = \left[ \frac{(i_1^2 + i_2^2 + i_3^2 + \dots + i_n^2) \Delta T}{n \cdot \Delta T} \right] R$$

$$I = \sqrt{\frac{(i_1^2 + i_2^2 + i_3^2 + \dots + i_n^2) \Delta T}{n \cdot \Delta T}} = \sqrt{\frac{\text{Area of } i^2 \text{ curve over half cycle}}{\text{Time period of half cycle}}}$$

$$= \sqrt{\frac{1}{T/2} \int_0^{T/2} i^2 dt} = \sqrt{\frac{2}{T} \int_0^{T/2} i^2 dt}$$

This value is termed as Root Mean Square (RMS) or effective one. Also to be noted that the same rms value of the current is obtained using the full cycle, or the time period.

### Average and RMS Values of Sinusoidal Voltage Waveform

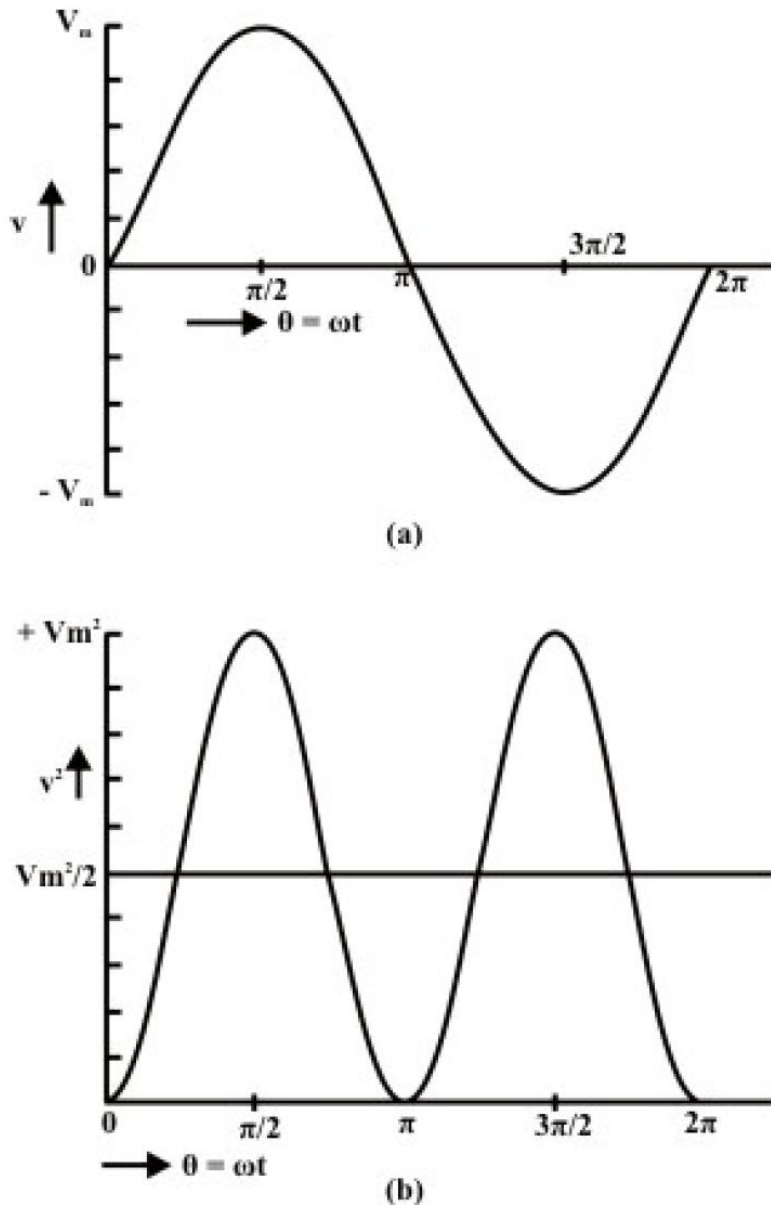

**Fig. 12.4 Sinusoidal voltage waveform  
(a) Voltage ( $v$ ), (b) Square of voltage ( $v^2$ )**

As shown earlier, normally the voltage generated, which is also transmitted and then distributed to the consumer, is the sinusoidal waveform with a frequency of 50 Hz in



this country. The waveform of the voltage  $v(t)$ , and the square of waveform,  $v^2(t)$ , are shown in figures 12.4a and 12.4b respectively.

Time period,  $T = 1/f = (2\pi)/\omega$ ; in angle ( $\omega T = 2\pi$ )

Half time period,  $T/2 = 1/(2f) = \pi/\omega$ ; in angle ( $\omega T/2 = \pi$ )

$v(\theta) = V_m \sin \theta$  for  $\pi \leq \theta \leq 0$ ;  $v(t) = V_m \sin \omega t$  for  $(\pi/\omega) \leq t \leq 0$

$$V_{av} = \frac{1}{\pi} \int_0^\pi v(\theta) d\theta = \frac{1}{\pi} \int_0^\pi V_m \sin \theta d\theta = \frac{V_m}{\pi} \cos \theta \Big|_0^\pi = \frac{2}{\pi} V_m = 0.637 V_m$$

$$V = \left[ \frac{1}{\pi} \int_0^\pi v^2 d\theta \right]^{\frac{1}{2}} = \left[ \frac{1}{\pi} \int_0^\pi V_m^2 \sin^2 \theta d\theta \right]^{\frac{1}{2}} = \left[ \frac{V_m^2}{\pi} \int_0^\pi \frac{1}{2} (1 - \cos 2\theta) d\theta \right]^{\frac{1}{2}}$$

$$= \left[ \frac{V_m^2}{2\pi} (\theta - \frac{1}{2} \sin 2\theta) \Big|_0^\pi \right]^{\frac{1}{2}} = \left[ \frac{V_m^2}{2\pi} \pi \right]^{\frac{1}{2}} = \frac{V_m}{\sqrt{2}} = 0.707 V_m$$

or,  $V_m = \sqrt{2} V$

If time  $t$ , is used as a variable, instead of angle  $\theta$ ,

$$V_{av} = \frac{1}{\pi/\omega} \int_0^{\pi/\omega} v(t) dt = \frac{\omega}{\pi} \int_0^{\pi/\omega} V_m \sin \omega t dt = \frac{\omega V_m}{\pi \omega} \cos (\omega t) \Big|_0^{\pi/\omega} = \frac{2}{\pi} V_m = 0.637 V_m$$

In the same way, the rms value,  $V$  can be determined.

If the average value of the above waveform is computed over total time period  $T$ , it comes out as zero, as the area of first (positive) half cycle is the same as that of second (negative) half cycle. However, the rms value remains same, if it is computed over total time period.

The different factors are defined as:

$$\text{Form factor} = \frac{\text{RMS value}}{\text{Average value}} = \frac{0.707 V_m}{0.637 V_m} = 1.11$$

$$\text{Peak factor} = \frac{\text{Maximum value}}{\text{Average value}} = \frac{V_m}{0.707 V_m} = 1.414$$

*Note:* The rms value is always greater than the average value, except for a rectangular waveform, in which case the heating effect remains constant, so that the average and the rms values are same.

## Symbols

$i$  or  $i(t)$  Instantaneous value of the current (sinusoidal form)

$I$  Current (rms value)

$I_m$  Maximum value of the current

$\bar{I}$  Phasor representation of the current

$\phi$  Phase angle, say of the current phasor, with respect to the reference phasor

Same symbols are used for voltage or any other phasor.



## Phasor Algebra

Before discussing the mathematical operations, like addition/subtraction and multiplication/division, involving phasors and also complex quantities, let us take a look at the two forms – polar and rectangular, by which a phasor or complex quantity is represented. It may be observed here that phasors are also taken as complex, as given above.

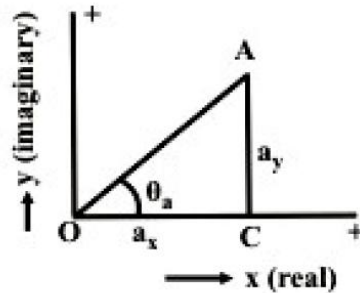

**Fig. 13.3 Representation of a phasor, both in rectangular and polar forms**

## Representation of a phasor and Transformation

A phasor or a complex quantity in rectangular form (Fig. 13.3) is,

$$\vec{A} = a_x + j a_y$$





where  $a_x$  and  $a_y$  are real and imaginary parts, of the phasor respectively.

In polar form, it is expressed as

$$\bar{A} = A \angle \theta_a = A \cos \theta_a + j A \sin \theta_a$$

where  $A$  and  $\theta_a$  are magnitude and phase angle of the phasor.

From the two equations or expressions, the procedure or rule of transformation from polar to rectangular form is

$$a_x = A \cos \theta_a \text{ and } a_y = A \sin \theta_a$$

From the above, the rule for transformation from rectangular to polar form is

$$A = \sqrt{a_x^2 + a_y^2} \text{ and } \theta_a = \tan^{-1}(a_y / a_x)$$

The examples using numerical values are given at the end of this lesson.

## Addition/Subtraction of Phasors

Before describing the rules of addition/subtraction of phasors or complex quantities, everyone should recall the rule of addition/subtraction of scalar quantities, which may be positive or signed (decimal/fraction or fraction with integer). It may be stated that, for the two operations, the quantities must be either phasors, or complex. The example of phasor is voltage/current, and that of complex quantity is impedance/admittance, which will be explained in the next lesson. But one phasor and another complex quantity should not be used for addition/subtraction operation.

For the operations, the two phasors or complex quantities must be expressed in rectangular form as

$$\bar{A} = a_x + j a_y ; \quad \bar{B} = b_x + j b_y$$

If they are in polar form as

$$\bar{A} = A \angle \theta_a ; \quad \bar{B} = B \angle \theta_b$$

In this case, two phasors are to be transformed to rectangular form by the procedure or rule given earlier.

The rule of addition/subtraction operation is that both the real and imaginary parts have to be separately treated as

$$\bar{C} = \bar{A} \pm \bar{B} = (a_x \pm b_x) + j(a_y \pm b_y) = c_x + j c_y$$

$$\text{where } c_x = (a_x \pm b_x) ; \quad c_y = (a_y \pm b_y)$$

Say, for addition, real parts must be added, so also for imaginary parts. Same rule follows for subtraction. After the result is obtained in rectangular form, it can be transformed to polar one. It may be observed that the six values of  $a$ 's,  $b$ 's and  $c$ 's – parts of the two phasors and the resultant one, are all signed scalar quantities, though in the example,  $a$ 's and  $b$ 's are taken as positive, resulting in positive values of  $c$ 's. Also the phase angle  $\theta$ 's may lie in any of the four quadrants, though here the angles are in the first quadrant only.

## Phasor Algebra

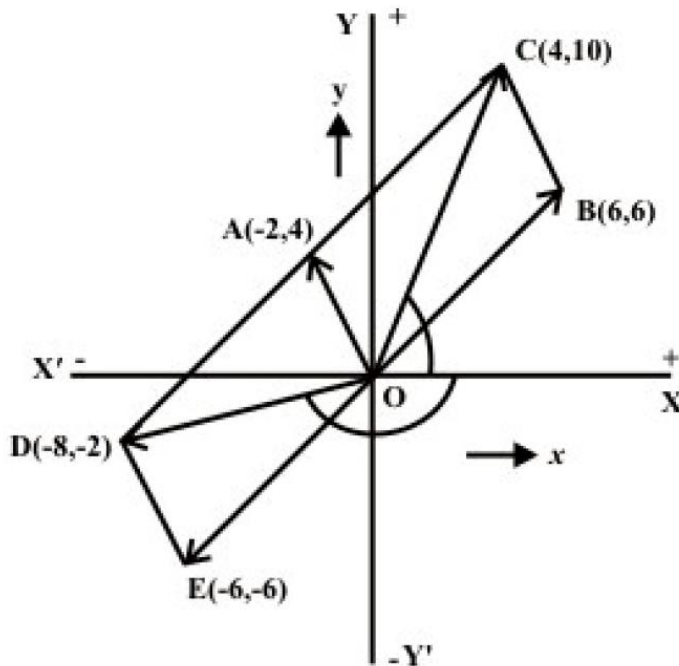

**Fig.13.6 Addition and subtraction of two phasors represented in polar form, as an example**

Another phasor,  $\bar{B}$  in rectangular form is introduced in addition to the earlier one,  $\bar{A}$   
 $\bar{B} = 6 + j6 = 8.485 \angle 45^\circ$

Firstly, let us take the addition and subtraction of the above two phasors. The sum and difference are given by the phasors,  $\bar{C}$  and  $\bar{D}$  respectively (Fig. 13.6).

$$\bar{C} = \bar{A} + \bar{B} = (-2 + j4) + (6 + j6) = (-2 + 6) + j(4 + 6) = 4 + j10 = 10.77 \angle 68.2^\circ$$

$$\bar{D} = \bar{A} - \bar{B} = (-2 + j4) - (6 + j6) = (-2 - 6) + j(4 - 6) = -8 - j2 = 8.246 \angle -166.0^\circ$$

It may be noted that for the addition and subtraction operations involving phasors, they should be represented in rectangular form as given above. If any one of the phasors



## Solution of Current in R-L-C Series Circuit

### Series (R-L-C) circuit

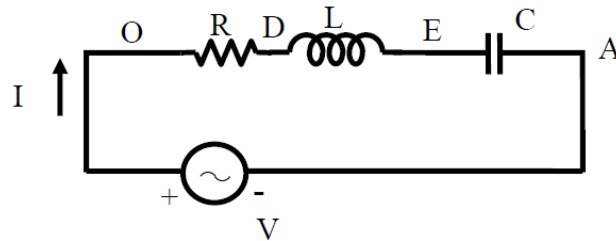

**Fig. 15.1 (a) Circuit diagram**

The voltage balance equation for the circuit with R, L and C in series (Fig. 15.1a), is

$$v = Ri + L \frac{di}{dt} + \frac{1}{C} \int i dt = \sqrt{2} V \sin \omega t$$



The current,  $i$  is of the form,

$$i = \sqrt{2} I \sin(\omega t \pm \phi)$$

As described in the previous lesson (#14) on series (R-L) circuit, the current in steady state is sinusoidal in nature. The procedure given here, in brief, is followed to determine the form of current. If the expression for  $i = \sqrt{2} I \sin(\omega t - \phi)$  is substituted in the voltage equation, the equation shown here is obtained, with the sides (LHS & RHS) interchanged.

$$\begin{aligned} R \cdot \sqrt{2} I \sin(\omega t - \phi) + \omega L \cdot \sqrt{2} I \cos(\omega t - \phi) - (1/\omega C) \cdot \sqrt{2} I \cos(\omega t - \phi) \\ = \sqrt{2} V \sin \omega t \end{aligned}$$

$$\text{or } R \cdot \sqrt{2} I \sin(\omega t - \phi) + [\omega L - (1/\omega C)] \cdot \sqrt{2} I \cos(\omega t - \phi) = \sqrt{2} V \sin \omega t$$

The steps to be followed to find the magnitude and phase angle of the current  $I$ , are same as described there (#14).

$$\text{So, the phase angle is } \phi = \tan^{-1}[\omega L - (1/\omega C)]/R$$

$$\text{and the magnitude of the current is } I = V/Z$$

$$\text{where the impedance of the series circuit is } Z = \sqrt{R^2 + [\omega L - (1/\omega C)]^2}$$

Alternatively, the steps to find the rms value of the current  $I$ , using complex form of impedance, are given here.

The impedance of the circuit is

$$Z \angle \pm \phi = R + j(X_L - X_C) = R + j\left(\omega L - \frac{1}{\omega C}\right)$$

where,

$$Z = \sqrt{R^2 + (X_L - X_C)^2} = \sqrt{R^2 + (\omega L - (1/\omega C))^2}, \text{ and}$$

$$\phi = \tan^{-1}\left(\frac{X_L - X_C}{R}\right) = \tan^{-1}\left(\frac{\omega L - (1/\omega C)}{R}\right)$$

$$\bar{I} \angle \mp \phi = \frac{\bar{V} \angle 0^\circ}{Z \angle \pm \phi} = \frac{V + j0}{R + j(X_L - X_C)} = \frac{V + j0}{R + j(\omega L - (1/\omega C))}$$

$$I = \frac{V}{Z} = \frac{V}{\sqrt{R^2 + (X_L - X_C)^2}} = \frac{V}{\sqrt{R^2 + \left(\omega L - \frac{1}{\omega C}\right)^2}}$$

Two cases are: (a) Inductive  $\left(\omega L > \frac{1}{\omega C}\right)$ , and (b) Capacitive  $\left(\omega L < \frac{1}{\omega C}\right)$ .

### (a) Inductive

In this case, the circuit is inductive, as total reactance  $(\omega L - (1/\omega C))$  is positive, under the condition  $(\omega L > (1/\omega C))$ . The current lags the voltage by  $\phi$  (taken as positive), with the voltage phasor taken as reference. The power factor (lagging) is less than 1 (one), as  $0^\circ \leq \phi \leq 90^\circ$ . The complete phasor diagram, with the voltage drops across the



components and input voltage ( $OA$ ), and also current ( $OB$ ), is shown in Fig. 15.1b. The voltage phasor is taken as reference, in all cases. It may be observed that

$$V_{OC} (= iR) + V_{CD} [= i(jX_L)] + V_{DA} [= -i(jX_C)] = V_{OA} (= iZ)$$

using the Kirchoff's second law relating to the voltage in a closed loop. The phasor diagram can also be drawn with the current phasor as reference, as will be shown in the example given here. The expression for the average power is  $VI \cos \phi = I^2 R$ . The power is only consumed in the resistance,  $R$ , but not in inductance/capacitance ( $L/C$ ), in all three cases.

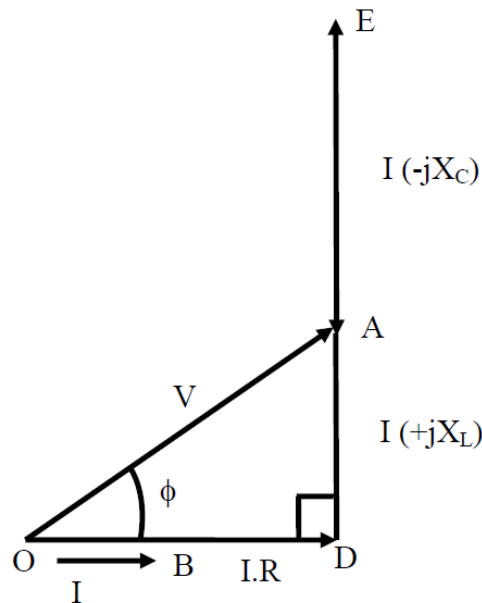

**Inductive ( $X_L > X_C$ )**

**Fig 15.1 (b) Phasor diagram**

In this case, the circuit is inductive, as total reactance ( $\omega L - (1/\omega C)$ ) is positive, under the condition ( $\omega L > (1/\omega C)$ ). The current lags the voltage by  $\phi$  (positive). The power factor (lagging) is less than 1 (one), as  $0^\circ \leq \phi \leq 90^\circ$ . The complete phasor diagram, with the voltage drops across the components and input voltage ( $OA$ ), and also current ( $OB$ ), is shown in Fig. 15.1b. The voltage phasor is taken as reference, in all cases. It may be observed that

$$V_{OC} (= iR) + V_{CD} [= i(jX_L)] + V_{DA} [= -i(jX_C)] = V_{OA} (= iZ)$$

using the Kirchoff's second law relating to the voltage in a closed loop. The phasor diagram can also be drawn with the current phasor as reference, as will be shown in the example given here. The expression for the average power is  $VI \cos \phi = I^2 R$ . The power is only consumed in the resistance,  $R$ , but not in inductance/capacitance ( $L/C$ ), in all three cases.



(b) Capacitive

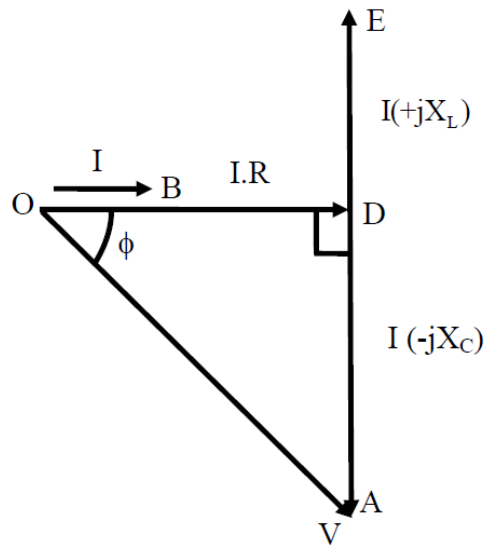

Capacitive ( $X_L < X_C$ )  
Fig 15.1 (c) Phasor diagram

The circuit is now capacitive, as total reactance ( $\omega L - (1/\omega C)$ ) is negative, under the condition ( $\omega L < (1/\omega C)$ ). The current leads the voltage by  $\phi$ , which is negative as per convention described in the previous lesson. The voltage phasor is taken as reference here. The complete phasor diagram, with the voltage drops across the components and input voltage, and also current, is shown in Fig. 15.1c. The power factor (leading) is less than 1 (one), as  $0^\circ \leq \phi \leq 90^\circ$ ,  $\phi$  being negative. The expression for the average power remains same as above.

The third case is resistive, as total reactance ( $\omega L - 1/\omega C$ ) is zero (0), under the condition ( $\omega L = 1/\omega C$ ). The impedance is  $Z \angle 0^\circ = R + j0$ . The current is now at unity power factor ( $\phi = 0^\circ$ ), i.e. the current and the voltage are in phase. The complete phasor diagram, with the voltage drops across the components and input (supply) voltage, and also current, is shown in Fig. 15.1d. This condition can be termed as ‘resonance’ in the series circuit, which is described in detail in lesson #17. The magnitude of the impedance in the circuit is minimum under this condition, with the magnitude of the current being maximum. One more point to be noted here is that the voltage drops in the inductance, L and also in the capacitance, C, is much larger in magnitude than the supply voltage, which is same as the voltage drop in the resistance, R. The phasor diagram has been drawn approximately to scale.

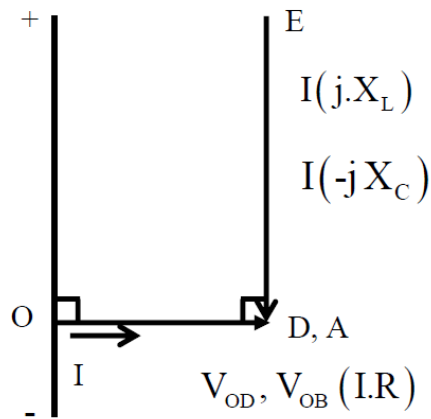

**Resistive ( $X_L = X_C$ )**

**Fig. 15.1 (d) Phasor diagram**

It may be observed here that two cases of series (R-L & R-C) circuits, as discussed in the previous lesson, are obtained in the following way. The first one (inductive) is that of (a), with C very large, i.e.  $1/\omega C \approx 0$ , which means that C is not there. The second one (capacitive) is that of (b), with L not being there ( $L$  or  $\omega L = 0$ ).



## Solution of Current in Parallel Circuit

### Parallel circuit

The circuit with all three elements, R, L & C connected in parallel (Fig. 15.4a), is fed to the ac supply. The current from the supply can be computed by various methods, of which two are described here.

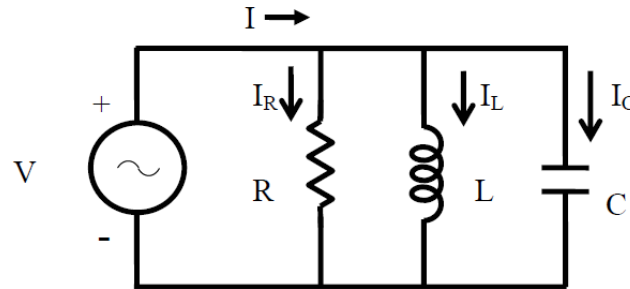

Fig. 15.4 (a) Circuit diagram.

### First method

The current in three branches are first computed and the total current drawn from the supply is the phasor sum of all three branch currents, by using Kirchoff's first law related to the currents at the node. The voltage phasor ( $V$ ) is taken as reference.

All currents, i.e. three branch currents and total current, in steady state, are sinusoidal in nature, as the input (supply voltage is sinusoidal of the form,

$$v = \sqrt{2} V \sin \omega t$$

Three branch currents are obtained by the procedure given in brief.

$$v = R \cdot i_R, \text{ or } i_R = v / R = \sqrt{2} (V / R) \sin \omega t = \sqrt{2} I_R \sin \omega t,$$

$$\text{where, } |I_R| = |(V / R)|$$

$$\text{Similarly, } v = L \frac{di_L}{dt}$$

So,  $i_L$  is,

$$i_L = (1/L) \int v dt = (1/L) \int \sqrt{2} V (\sin \omega t) dt = -\sqrt{2} [V / (\omega L)] \cos \omega t = -\sqrt{2} I_L \cos \omega t$$

$$= \sqrt{2} I_L \sin(\omega t - 90^\circ)$$





where,  $|I_L| = |V/X_L|$  with  $X_L = \omega L$

$v = (1/C) \int i_c dt$ , from which  $i_c$  is obtained as,

$$\begin{aligned} i_c &= C \frac{dv}{dt} = C \frac{d}{dt} (\sqrt{2} V \sin \omega t) = \sqrt{2} (V \cdot \omega C) \cos \omega t = \sqrt{2} I_C \cos \omega t \\ &= \sqrt{2} I_C \sin(\omega t + 90^\circ) \end{aligned}$$

where,  $|I_c| = |V/X_C|$  with  $X_C = (1/\omega C)$

Total (supply) current,  $i$  is

$$\begin{aligned} i &= i_R + i_L + i_c = \sqrt{2} I_R \sin \omega t - \sqrt{2} I_L \cos \omega t + \sqrt{2} I_C \cos \omega t \\ &= \sqrt{2} I_R \sin \omega t - \sqrt{2} (I_L - I_C) \cos \omega t = \sqrt{2} I \sin(\omega t \mp \phi) \end{aligned}$$

The two equations given here are obtained by expanding the trigonometric form appearing in the last term on RHS, into components of  $\cos \omega t$  and  $\sin \omega t$ , and then equating the components of  $\cos \omega t$  and  $\sin \omega t$  from the last term and last but one (previous).

$$I \cos \phi = I_R \text{ and } I \sin \phi = (I_L - I_C)$$

From these equations, the magnitude and phase angle of the total (supply) current are,

$$\begin{aligned} |I| &= \sqrt{(I_R)^2 + (I_L - I_C)^2} = |V| \cdot \sqrt{\left(\frac{1}{R}\right)^2 + \left(\frac{1}{X_L} - \frac{1}{X_C}\right)^2} \\ &= |V| \cdot \sqrt{\left(\frac{1}{R}\right)^2 + \left(\frac{1}{\omega L} - \omega C\right)^2} = |V| \cdot |Y| \\ \phi &= \tan^{-1} \left( \frac{I_L - I_C}{I_R} \right) = \tan^{-1} \left( \frac{(1/X_L) - (1/X_C)}{(1/R)} \right) = \tan^{-1} \left[ R \cdot \left( \frac{1}{X_L} - \frac{1}{X_C} \right) \right] \\ &= \tan^{-1} \left[ R \cdot \left( \frac{1}{\omega L} - \omega C \right) \right] \end{aligned}$$

where, the magnitude of the term (admittance of the circuit) is,

$$|Y| = \sqrt{\left(\frac{1}{R}\right)^2 + \left(\frac{1}{X_L} - \frac{1}{X_C}\right)^2} = \sqrt{\left(\frac{1}{R}\right)^2 + \left(\frac{1}{\omega L} - \omega C\right)^2}$$

Please note that the admittance, which is reciprocal of impedance, is a complex quantity. The angle of admittance or impedance, is same as the phase angle,  $\phi$  of the current  $I$ , with the input (supply) voltage taken as reference phasor, as given earlier.

Alternatively, the steps required to find the rms values of three branch currents and the total (supply) current, using complex form of impedance, are given here.

Three branch currents are

$$I_R \angle 0^\circ = I_R = \frac{V}{R}; \quad I_L \angle -90^\circ = -j I_L = \frac{V}{j X_L} = \frac{V}{j \omega L} = -j \frac{V}{\omega L}$$

$$I_C \angle +90^\circ = j I_C = \frac{V}{-j X_C} = \frac{V}{-j (1/\omega C)} = j \omega C V$$

Of the three branches, the first one consists of resistance only, the current,  $I_R$  is in phase with the voltage (V). In the second branch, the current,  $I_L$  lags the voltage by  $90^\circ$ , as there is inductance only, while in the third one having capacitance only, the current,  $I_C$  leads the voltage  $90^\circ$ . All these cases have been presented in the previous lesson.

The total current is

$$I \angle \pm \phi = I_R + j(I_C - I_L) = V \left[ \frac{1}{R} + j \left( \omega C - \frac{1}{\omega L} \right) \right]$$

where,

$$I = \sqrt{I_R^2 + (I_C - I_L)^2} = V \sqrt{\left[ \frac{1}{R^2} + \left( \omega C - \frac{1}{\omega L} \right)^2 \right]}, \text{ and}$$

$$\phi = \tan^{-1} \left( \frac{I_C - I_L}{I_R} \right) = \tan^{-1} \left[ R \left( \omega C - \frac{1}{\omega L} \right) \right]$$

The two cases are as described earlier in series circuit.

**(a) Inductive**

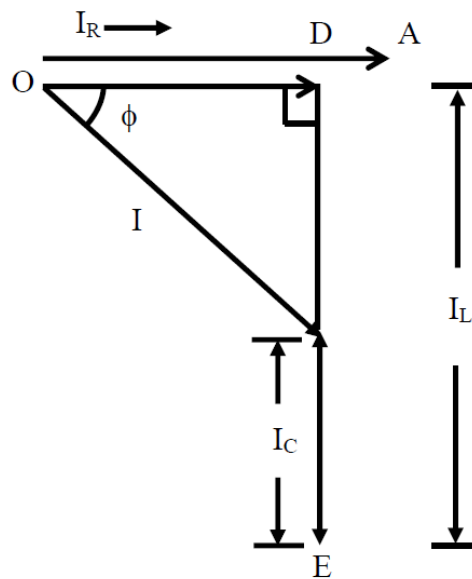

**Inductive ( $I_L > I_C$ )**

**Fig. 15.4 (b) Phasor diagram**

In this case, the circuit being inductive, the current lags the voltage by  $\phi$  (positive), as  $I_L > I_C$ , i.e.  $1/\omega L > \omega C$ , or  $\omega L < 1/\omega C$ . This condition is in contrast to that derived in the case of series circuit earlier. The power factor is less than 1 (one). The complete phasor diagram, with the three branch currents along with total current, and also the voltage, is shown in Fig. 15.4b. The voltage phasor is taken as reference in all cases. It may be observed there that

$$I_R(OD) + I_L(DC) + I_C(CB) = I(OB)$$



The Kirchoff's first law related to the currents at the node is applied, as stated above. The expression for the average power is  $V I \cos \phi = I_R^2 R = V^2 / R$ . The power is only consumed in the resistance, R, but not in inductance/capacitance (L/C), in all three cases.

**(b) Capacitive**

The circuit is capacitive, as  $I_C > I_L$ , i.e.  $\omega C > 1/\omega L$ , or  $\omega L > 1/\omega C$ . The current leads the voltage by  $\phi$  ( $\phi$  being negative), with the power factor less than 1 (one). The complete phasor diagram, with the three branch currents along with total current, and also the voltage, is shown in Fig. 15.4c.

The third case is resistive, as  $|I_L| = |I_C|$ , i.e.  $1/\omega L = \omega C$  or  $\omega L = 1/\omega C$ . This is the same condition, as obtained in the case of series circuit. It may be noted that two currents,  $I_L$  and  $I_C$ , are equal in magnitude as shown, but opposite in sign (phase difference being  $180^\circ$ ), and the sum of these currents ( $I_L + I_C$ ) is zero (0). The total current is in phase with the voltage ( $\phi = 0^\circ$ ), with  $|I| = |I_R|$ , the power factor being unity. The complete phasor diagram, with the three branch currents along with total current, and also the voltage, is shown in Fig. 15.4d. This condition can be termed as 'resonance' in the parallel circuit, which is described in detail in lesson #17. The magnitude of the impedance in the circuit is maximum (i.e., the magnitude of the admittance is minimum) under this condition, with the magnitude of the total (supply) current being minimum.

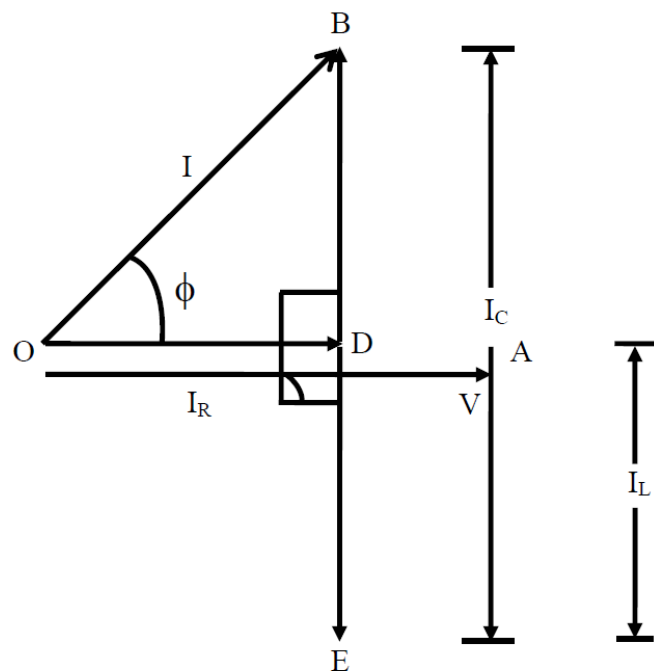

**Capacitive ( $I_L < I_C$ )**

**Fig. 15.4 (c) Phasor diagram**



The circuit with two elements, say R & L, can be solved, or derived with C being large ( $I_C = 0$  or  $1/\omega C = 0$ ).

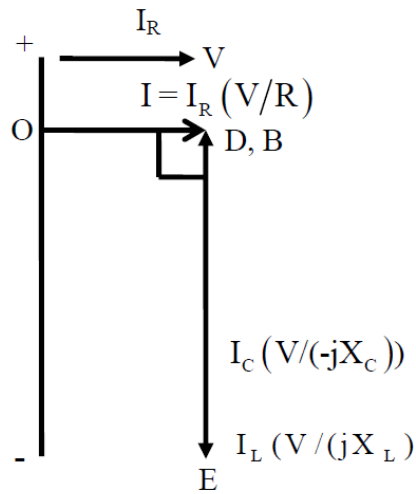

**Resistive ( $I_L = I_C$ )**

**Fig. 15.4 (d) Phasor Diagram**

## Resonance in Series and Parallel Circuits

### Series circuit

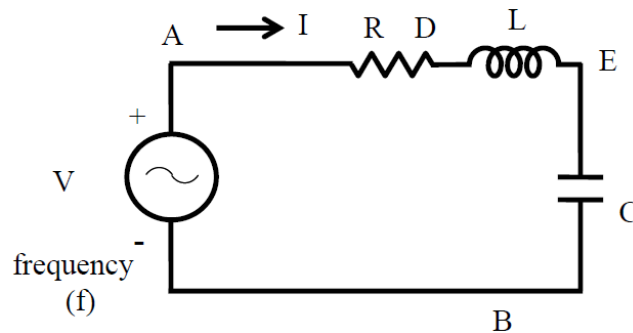

**Fig. 17.1 (a) Circuit diagram.**

The circuit, with resistance R, inductance L, and a capacitor, C in series (Fig. 17.1a) is connected to a single phase variable frequency ( $f$ ) supply.

The total impedance of the circuit is



$$Z \angle \phi = R + j \left( \omega L - \frac{1}{\omega C} \right)$$

where,

$$Z = \sqrt{R^2 + \left( \omega L - \frac{1}{\omega C} \right)^2} ; \quad \phi = \tan^{-1} \frac{(\omega L - 1/\omega C)}{R} ; \quad \omega = 2\pi f$$

The current is

$$I \angle -\phi = \frac{V \angle 0^\circ}{Z \angle \phi} = (V/Z) \angle -\phi$$

$$\text{where } I = \frac{V}{\left[ R^2 + (\omega L - (1/\omega C))^2 \right]^{1/2}}$$

The current in the circuit is maximum, if  $\omega L = \frac{1}{\omega C}$  .

The frequency under the above condition is

$$f_o = \frac{\omega_o}{2\pi} = \frac{1}{2\pi\sqrt{LC}}$$

This condition under the magnitude of the current is maximum, or the magnitude of the impedance is minimum, is called resonance. The frequency under this condition with the constant values of inductance L, and capacitance C, is called resonant frequency. If the capacitance is variable, and the frequency,  $f$  is kept constant, the value of the capacitance needed to produce this condition is

$$C = \frac{1}{\omega^2 L} = \frac{1}{(2\pi f)^2 L}$$

The magnitude of the impedance under the above condition is  $|Z| = R$ , with the reactance  $X = 0$ , as the inductive reactance  $X_L = \omega L$  is equal to capacitive reactance  $X_C = 1/\omega C$ . The phase angle is  $\phi = 0^\circ$ , and the power factor is unity ( $\cos \phi = 1$ ), which means that the current is in phase with the input (supply) voltage.. So, the magnitude of the current ( $|V/R|$ ) in the circuit is only limited by resistance, R. The phasor diagram is shown in Fig. 17.1b.

The magnitude of the voltage drop in the inductance L/capacitance C (both are equal, as the reactance are equal) is  $I \cdot \omega_o L = I \cdot (1/\omega_o C)$  .

The magnification of the voltage drop as a ratio of the input (supply) voltage is

$$Q = \frac{\omega_o L}{R} = \frac{2\pi f_o L}{R} = \frac{1}{R} \sqrt{\frac{L}{C}}$$

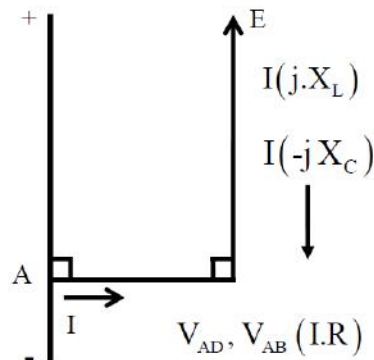

**Fig. 17.1 (b) Phasor Diagram**

It is termed as Quality (Q) factor of the coil.

The impedance of the circuit with the constant values of inductance L, and capacitance C is minimum at resonant frequency ( $f_o$ ), and increases as the frequency is changed, i.e. increased or decreased, from the above frequency. The current is maximum at  $f = f_o$ , and decreases as frequency is changed ( $f > f_o$ , or  $f < f_o$ ), i.e.  $f \neq f_o$ . The variation of current in the circuit having a known value of capacitance with a variable frequency supply is shown in Fig. 17.2.

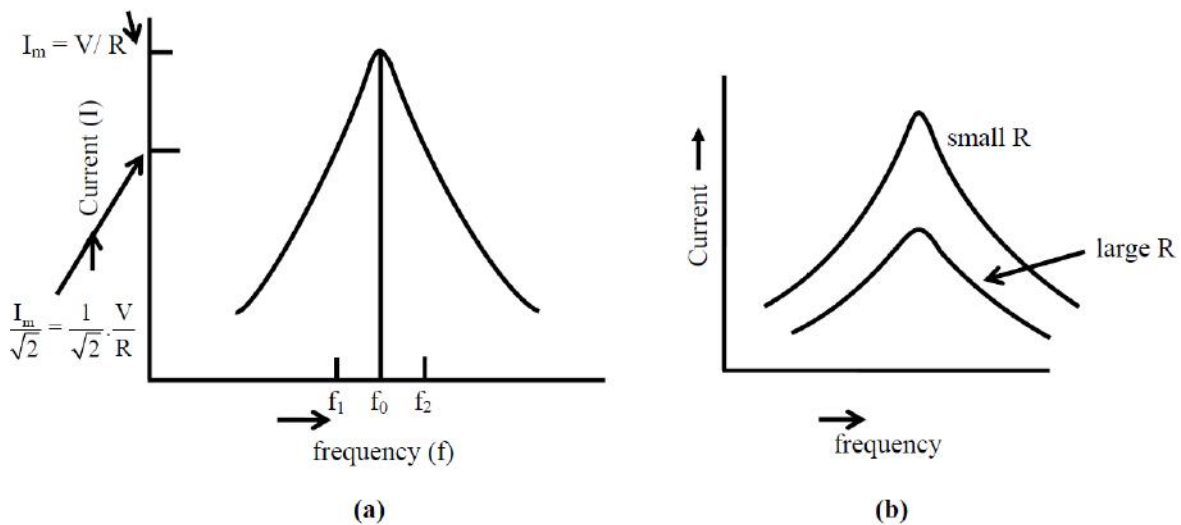

**Fig. 17.2 Variation of current under variable frequency supply**

The maximum value of the current is ( $V/R$ ). If the magnitude of the current is reduced to ( $1/\sqrt{2}$ ) of its maximum value, the power consumed in R will be half of that with the maximum current, as power is  $I^2R$ . So, these points are termed as half power



points. If the two frequencies are taken as  $f_1$  and  $f_2$ , where  $f_1 = f_0 - \Delta f / 2$  and  $f_2 = f_0 + \Delta f / 2$ , the band width being given by  $\Delta f = f_2 - f_1$ .

The magnitude of the impedance with the two frequencies is

$$Z = \left[ R^2 + \left( 2\pi(f_0 \pm \Delta f / 2)L - \frac{1}{2\pi(f_0 \pm \Delta f / 2)C} \right)^2 \right]^{\frac{1}{2}}$$

As  $(2\pi f_0 L = 1 / 2\pi f_0 C)$  and the ratio  $(\Delta f / 2 f_0)$  is small, the magnitude of the reactance of the circuit at these frequencies is  $X = X_{L0} (\Delta f / f_0)$ . As the current is  $(1 / \sqrt{2})$  of its maximum value, the magnitude of the impedance is  $(\sqrt{2})$  of its minimum value (R) at resonant frequency.

$$\text{So, } Z = \sqrt{2} \cdot R = \left[ R^2 + (X_{L0} (\Delta f / f_0))^2 \right]^{\frac{1}{2}}$$

From the above, it can be obtained that  $(\Delta f / f_0) X_{L0} = R$

$$\text{or } \Delta f = f_2 - f_1 = \frac{R f_0}{X_{L0}} = \frac{R f_0}{2\pi f_0 L} = \frac{R}{2\pi L}$$

The band width is given by  $\Delta f = f_2 - f_1 = R / (2\pi L)$

It can be observed that, to improve the quality factor (Q) of a coil, it must be designed to have its resistance, R as low as possible. This also results in reduction of band width and losses (for same value of current). But if the resistance, R cannot be decreased, then Q will decrease, and also both band width and losses will increase.

### Parallel circuit

The circuit, with resistance R, inductance L, and a capacitor, C in parallel (Fig. 17.4a) is connected to a single phase variable frequency ( $f$ ) supply.

The total admittance of the circuit is

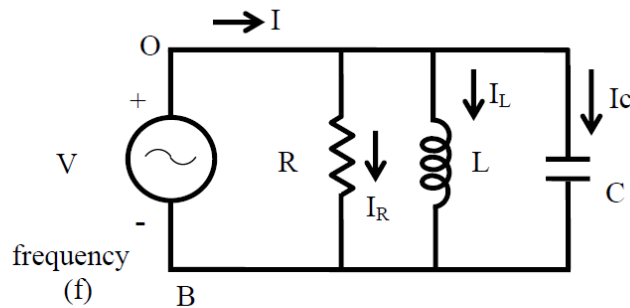

Fig. 17.4 (a) Circuit diagram.

$$Y \angle \phi = \frac{1}{R} + j \left( \omega C - \frac{1}{\omega L} \right)$$

where,



$$Y = \sqrt{\left[ \frac{1}{R^2} + \left( \omega C - \frac{1}{\omega L} \right)^2 \right]} ; \quad \phi = \tan^{-1} \left[ R \left( \omega C - \frac{1}{\omega L} \right) \right] ; \quad \omega = 2\pi f$$

The impedance is  $Z \angle -\phi = 1/Y \angle \phi$

The current is

$$I \angle \phi = V \angle 0^\circ \cdot Y \angle \phi = (V \cdot Y) \angle \phi = V \angle 0^\circ / Z \angle -\phi = (V/Z) \angle \phi$$

$$\text{where, } I = V \sqrt{\left[ \frac{1}{R^2} + \left( \omega C - \frac{1}{\omega L} \right)^2 \right]}$$

The current in the circuit is minimum, if  $\omega C = \frac{1}{\omega L}$

The frequency under the above condition is

$$f_o = \frac{\omega_o}{2\pi} = \frac{1}{2\pi\sqrt{LC}}$$

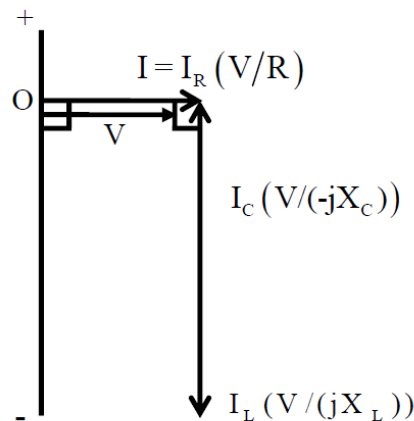

**Fig. 17.4 (b) Phasor Diagram**

This condition under which the magnitude of the total (supply) current is minimum, or the magnitude of the admittance is minimum (which means that the impedance is maximum), is called resonance. It may be noted that, for parallel circuit, the current or admittance is minimum (the impedance being maximum), while for series circuit, the current is maximum (the impedance being minimum). The frequency under this condition with the constant values of inductance L, and capacitance C, is called resonant frequency. If the capacitance is variable, and the frequency, f is kept constant, the value of the capacitance needed to produce this condition is

$$C = \frac{1}{\omega^2 L} = \frac{1}{(2\pi f)^2 L}$$

The magnitude of the impedance under the above condition is ( $|Z| = R$ ), while the magnitude of the admittance is ( $|Y| = G = (1/R)$ ). The reactive part of the admittance is





$B = 0$ , as the susceptance (inductive)  $B_L = (1/\omega L)$  is equal to the susceptance (capacitive)  $B_C = \omega C$ . The phase angle is  $\phi = 0^\circ$ , and the power factor is unity ( $\cos \phi = 1$ ). The total (supply) current is phase with the input voltage. So, the magnitude of the total current ( $|V/R|$ ) in the circuit is only limited by resistance R. The phasor diagram is shown in Fig. 17.4b.

The magnitude of the current in the inductance, L / capacitance, C (both are equal, as the reactance are equal), is  $V(1/\omega_o L) = V \cdot \omega_o C$ . This may be termed as the circulating current in the circuit with only inductance and capacitance, the magnitude of which is

$$|I_L| = |I_C| = V \sqrt{\frac{C}{L}}$$

substituting the value of  $\omega_o = 2\pi f_o$ . This circulating current is smaller in magnitude than the input current or the current in the resistance as  $\omega_o C = (1/\omega_o L) > R$ .

The input current increases as the frequency is changed, i.e. increased or decreased from the resonant frequency ( $f > f_o$ , or  $f < f_o$ ), i.e.  $f \neq f_o$ .

In the two cases of series and parallel circuits described earlier, all components, including the inductance, are assumed to be ideal, which means that the inductance is lossless, having no resistance. But, in actual case, specially with an iron-cored choke coil, normally a resistance r is assumed to be in series with the inductance L, to take care of the winding resistance and also the iron loss in the core. In an air-cored coil, the winding resistance may be small and no loss occurs in the air core.

An iron-cored choke coil is connected in parallel to capacitance, and the combination is fed to an ac supply (Fig. 17.5a).

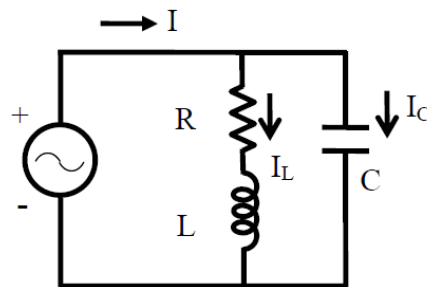

**Fig. 17.5 (a) Circuit diagram.**

The total admittance of the circuit is

$$Y = Y_1 + Y_2 = \frac{1}{r + j\omega L} + j\omega C = \frac{r - j\omega L}{r^2 + \omega^2 L^2} + j\omega C$$

If the magnitude of the admittance is to be minimum, then

$$\omega C = \frac{\omega L}{r^2 + \omega^2 L^2} \text{ or } C = \frac{L}{r^2 + \omega^2 L^2} .$$

The frequency is



$$f_o = \frac{\omega_o}{2\pi} = \frac{1}{2\pi} \sqrt{\frac{L}{C} - r^2}$$

This is the resonant frequency. The total admittance is  $Y \angle 0^\circ = \frac{r}{r^2 + \omega^2 L^2}$

The total impedance is  $Z \angle 0^\circ = \frac{r^2 + \omega^2 L^2}{r}$

The total (input) current is

$$I \angle 0^\circ = \frac{V \angle 0^\circ}{Z \angle 0^\circ} = V \angle 0^\circ \cdot Y \angle 0^\circ = \left(\frac{V}{Z}\right) \angle 0^\circ = (V \cdot Y) \angle 0^\circ = \frac{V \cdot r}{r^2 + \omega^2 L^2}$$

This current is at unity power factor with  $\phi = 0^\circ$ . The total current can be written as

$$I \angle 0^\circ = I + j0 = I_L \angle -\phi_L + jI_C = I_L \cos \phi_L + j(I_L \sin \phi_L - I_C)$$

So, the condition is  $I_C = I_L \sin \phi_L$

$$\text{where } I_C = \frac{V}{X_C} = V \cdot \omega C ; \quad I_L = \frac{V}{\sqrt{r^2 + \omega^2 L^2}} ; \quad \sin \phi_L = \frac{\omega L}{\sqrt{r^2 + \omega^2 L^2}}$$

From the above, the condition, as given earlier, can be obtained.

The total current is  $I = I_L \cos \phi_L$

The value, as given here, can be easily obtained. The phasor diagram is shown in Fig. 17.5b. It may also be noted that the magnitude of the total current is minimum, while the magnitude of the impedance is maximum.

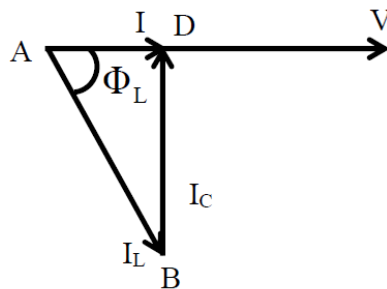

**Fig. 17.5 (b) Phasor Diagram**

### Methods for Power Factor Improvement

The following devices and equipment are used for Power Factor Improvement.

1. Static Capacitor
2. Synchronous Condenser
3. Phase Advancer

#### 1. Static Capacitor

We know that most of the industries and power system loads are inductive that take lagging current which decrease the system power factor (See Disadvantages of Low Power factor) . For Power factor improvement purpose, Static capacitors are connected in parallel with those devices which work on low power factor.



These static capacitors provides leading current which neutralize (totally or approximately) the lagging inductive component of load current (i.e. leading component neutralize or eliminate the lagging component of load current) thus power factor of the load circuit is improved.

These capacitors are installed in Vicinity of large inductive load e.g Induction motors and transformers etc, and improve the load circuit power factor to improve the system.

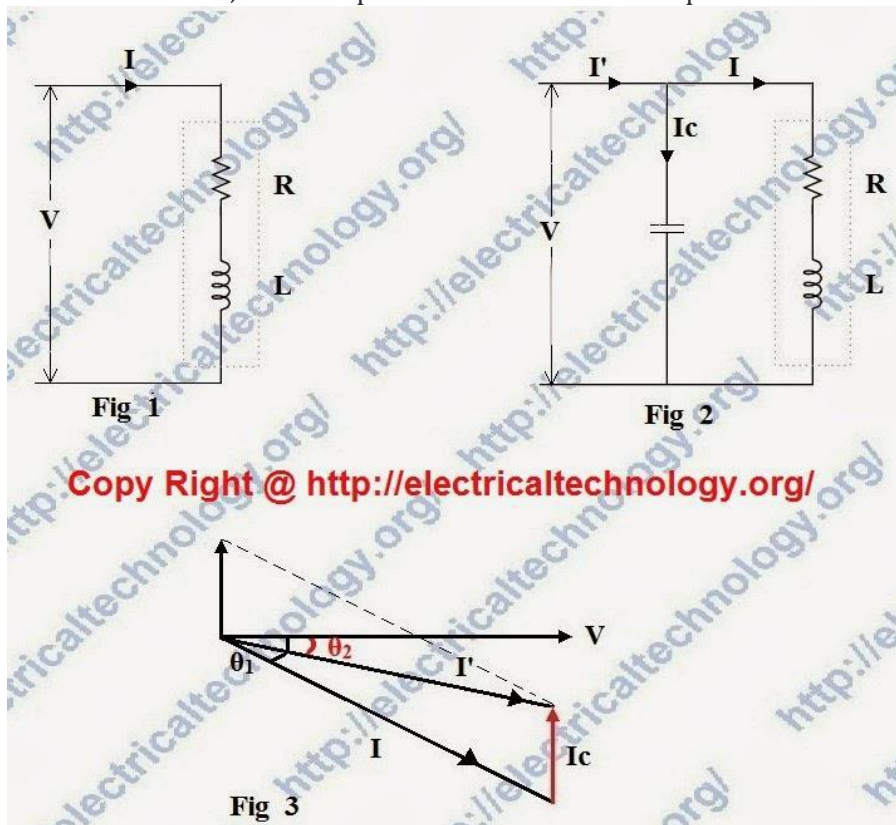

Suppose, here is a single phase inductive load which is taking lagging current (I) and the load power factor is  $\cos\theta$  as shown in fig-1.

In fig-2, a Capacitor (C) has been connected in parallel with load. Now a current ( $I_c$ ) is flowing through Capacitor which lead  $90^\circ$  from the supply voltage ( Note that Capacitor provides leading Current i.e., In a pure capacitive circuit, Current leading  $90^\circ$  from the supply Voltage, in other words, Voltage are  $90^\circ$  lagging from Current). The load current is (I). The Vectors combination of (I) and ( $I_c$ ) is ( $I'$ ) which is lagging from voltage at  $\theta_2$  as shown in fig 3.

It can be seen from fig 3 that angle of  $\theta_2 < \theta_1$  i.e. angle of  $\theta_2$  is less than from angle of  $\theta_1$ . Therefore  $\cos\theta_2$  is less than from  $\cos\theta_1$  ( $\cos\theta_2 > \cos\theta_1$ ). Hence the load power factor is improved by capacitor.



Also note that after the power factor improvement, the circuit current would be less than from the low power factor circuit current. Also, before and after the power factor improvement, the active component of current would be same in that circuit because capacitor eliminates only the re-active component of current. Also, the Active power (in Watts) would be same after and before power factor improvement.

### Advantages:

- Capacitor bank offers several advantages over other methods of power factor improvement.
- Losses are low in static capacitors
- There is no moving part, therefore need low maintenance
- It can work in normal conditions (i.e. ordinary atmospheric conditions)
- Do not require a foundation for installation
- They are lightweight so it is can be easy to installed

### Disadvantages:

- The age of static capacitor bank is less (8 – 10 years)
- With changing load, we have to ON or OFF the capacitor bank, which causes switching surges on the system
- If the rated voltage increases, then it causes damage it
- Once the capacitors spoiled, then repairing is costly

## 2. Synchronous Condenser

When a Synchronous motor operates at No-Load and over-excited then it's called a synchronous Condenser. Whenever a Synchronous motor is over-excited then it provides leading current and works like a capacitor. When a synchronous condenser is connected across supply voltage (in parallel) then it draws leading current and partially eliminates the re-active component and this way, power factor is improved. Generally, synchronous condenser is used to improve the power factor in large industries.

### Advantages:

- Long life (almost 25 years)
- High Reliability
- Step-less adjustment of power factor.
- No generation of harmonics of maintenance
- The faults can be removed easily
- It's not affected by harmonics.
- Require Low maintenance (only periodic bearing greasing is necessary)

### Disadvantages:

- It is expensive (maintenance cost is also high) and therefore mostly used by large power users.
- An auxiliary device has to be used for this operation because synchronous motor has no self starting torque



- It produces noise

### 3. Phase Advancer

Phase advancer is a simple AC exciter which is connected on the main shaft of the motor and operates with the motor's rotor circuit for power factor improvement. Phase advancer is used to improve the power factor of induction motor in industries.

As the stator windings of induction motor takes lagging current  $90^\circ$  out of phase with Voltage, therefore the power factor of induction motor is low. If the exciting ampere-turns are excited by external AC source, then there would be no effect of exciting current on stator windings. Therefore the power factor of induction motor will be improved. This process is done by Phase advancer.

#### Advantages:

- Lagging kVAR (Reactive component of Power or reactive power) drawn by the motor is sufficiently reduced because the exciting ampere turns are supplied at slip frequency ( $f_s$ ).
- The phase advancer can be easily used where the use of synchronous motors is Unacceptable

#### Disadvantage:

- Using Phase advancer is not economical for motors below 200 H.P. (about 150kW)

#### Following are the causes of low Power factor:

- 1. Single phase and three phase induction Motors**(Usually, Induction motor works at poor power factor i.e. at:  
Full load,  $Pf = 0.8 - 0.9$   
Small load,  $Pf = 0.2 - 0.3$   
No Load,  $Pf$  may come to Zero (0).
- 2. Varying Load in Power System**(As we know that load on power system is varying. During low load period, supply voltage is increased which increase the magnetizing current which cause the decreased power factor)
- 3. Industrial heating furnaces**
- 4. Electrical discharge lamps** (High intensity discharge lighting) Arc lamps (operate a very low power factor)
- 5. Transformers**
- 6. Harmonic Currents**

## Three-phase Voltages for Star Connection

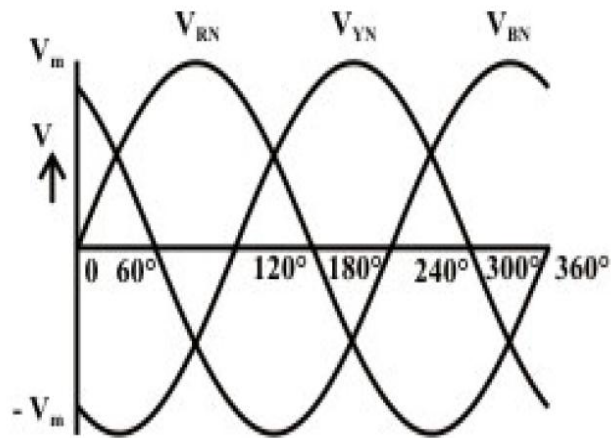

**Fig. 18.1 (b) Three-phase balanced voltage waveforms with the source star-connected (the phase sequence, R-Y-B)**

The connection diagram of a star (Y)-connected three-phase system is shown in Fig. 18.2a, along with phasor representation of the voltages (Fig. 18.2b). These are in continuation of the figures 18.1a-b. Three windings for three phases are R (+) & R'(-), Y (+) & Y'(-), and B (+) & Y'(-). Taking the winding of one phase, say phase R as an example, then R with sign (+) is taken as start, and R' with sign (-) is taken as finish. Same is the case with two other phases. For making star (Y)-connection, R', Y' & B' are connected together, and the point is taken as neutral, N. Three phase voltages are:

$$e_{RN} = E_m \sin \theta; \quad e_{YN} = E_m \sin (\theta - 120^\circ);$$

$$e_{BN} = E_m \sin (\theta - 240^\circ) = E_m \sin (\theta + 120^\circ)$$

It may be noted that, if the voltage in phase R ( $e_{RN}$ ) is taken as reference as stated earlier, then the voltage in phase Y ( $e_{YN}$ ) lags  $e_{RN}$  by  $120^\circ$ , and the voltage in phase B ( $e_{BN}$ ) lags  $e_{YN}$  by  $120^\circ$ , or leads  $e_{RN}$  by  $120^\circ$ . The phasors are given as:

$$E_{RN} \angle 0^\circ = E(1.0 + j0.0):$$

$$E_{YN} \angle -120^\circ = E(-0.5 - j0.866);$$

$$E_{BN} \angle +120^\circ = E(-0.5 + j0.866).$$

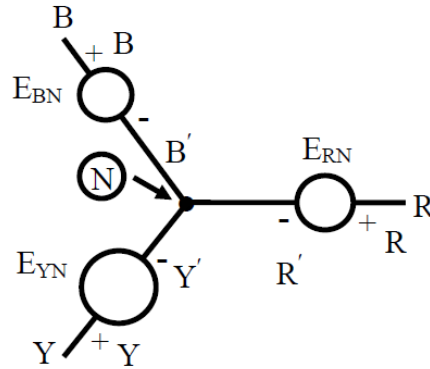

(a)

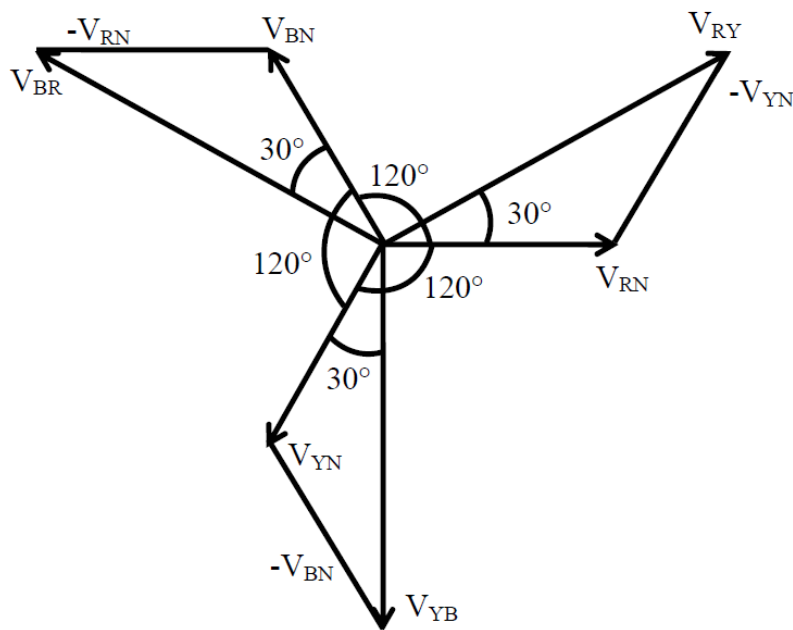

(b)

**Fig. 18.2 (a) Three-phase balanced voltages, with the source star-connected (the phase sequence, R-Y-B)  
(b) Phasor diagram of the line and phase voltages**

The phase voltages are all equal in magnitude, but only differ in phase. This is also shown in Fig. 18.2b. The relationship between  $E$  and  $E_m$  is  $E = E_m / \sqrt{2}$ . The phase sequence is R-Y-B. It can be observed from Fig. 18.1b that the voltage in phase Y attains the maximum value, after  $\theta = \omega \cdot t = 120^\circ$  from the time or angle, after the voltage in phase R attains the maximum value, and then the voltage in phase B attains the maximum value. The angle of lag or lead from the reference phase, R is stated earlier.



## Relation between the Phase and Line Voltages for Star Connection

Three line voltages (Fig. 18.4) are obtained by the following procedure. The line voltage,  $E_{RY}$  is

$$\begin{aligned} E_{RY} &= E_{RN} - E_{YN} = E \angle 0^\circ - E \angle -120^\circ = E [(1 + j0) - (-0.5 - j0.866)] \\ &= E (1.5 + j0.866) = \sqrt{3} E \angle 30^\circ \end{aligned}$$

The magnitude of the line voltage,  $E_{RY}$  is  $\sqrt{3}$  times the magnitude of the phase voltage  $E_{RN}$ , and  $E_{RY}$  leads  $E_{RN}$  by  $30^\circ$ . Same is the case with other two line voltages as shown in brief (the steps can easily be derived by the procedure given earlier).

$$E_{YB} = E_{YN} - E_{BN} = E \angle -120^\circ - E \angle +120^\circ = \sqrt{3} E \angle -90^\circ$$

$$E_{BR} = E_{BN} - E_{RN} = E \angle +120^\circ - E \angle 0^\circ = \sqrt{3} E \angle +150^\circ$$

So, the three line voltages are balanced, with their magnitudes being equal, and the phase angle being displaced from each other in sequence by  $120^\circ$ . Also, the line voltage, say  $E_{RY}$ , leads the corresponding phase voltage,  $E_{RN}$  by  $30^\circ$



## Relation between the Phase and Line Voltages for Delta Connection

The connection diagram of a delta ( $\Delta$ )-connected three-phase system is shown in Fig. 18.4a, along with phasor representation of the voltages (Fig. 18.4b). For making delta ( $\Delta$ )-connection, the start of one winding is connected to the finish of the next one in sequence, for instance, starting from phase R, R' is to be connected to Y, and then Y' to B, and so on (Fig. 18.4a). The line and phase voltages are the same in this case, and are given as

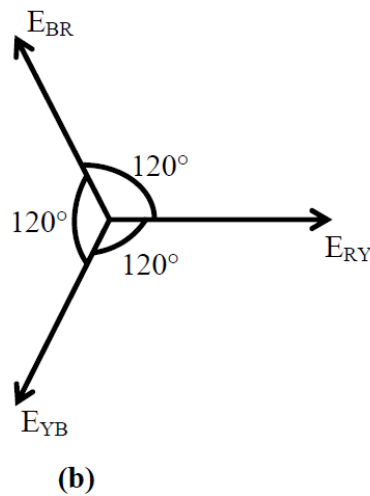
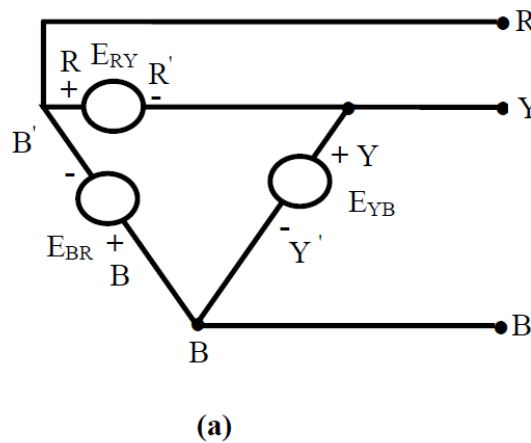

**Fig. 18.4 (a) Three-phase balanced voltages, with the source delta-connected (the phase sequence, R-Y-B)**

**(b) Phasor diagram of the line and phase voltages**

$$E_{RY} = E \angle 0^\circ; \quad E_{YB} = E \angle -120^\circ; \quad E_{BR} = E \angle +120^\circ$$

## Relation between the Phase and Line Voltages for Delta Connection

The connection diagram of a delta ( $\Delta$ )-connected three-phase system is shown in Fig. 18.4a, along with phasor representation of the voltages (Fig. 18.4b). For making delta ( $\Delta$ )-connection, the start of one winding is connected to the finish of the next one in sequence, for instance, starting from phase R, R' is to be connected to Y, and then Y' to B, and so on (Fig. 18.4a). The line and phase voltages are the same in this case, and are given as

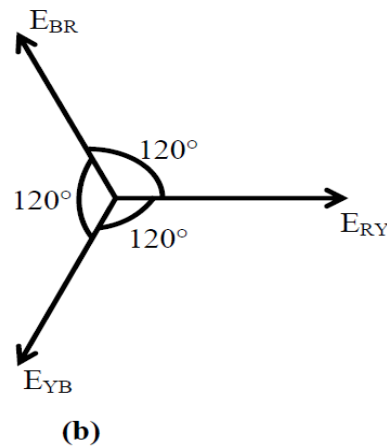
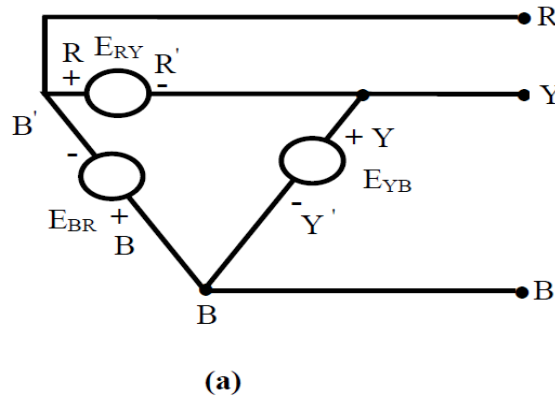

**Fig. 18.4 (a) Three-phase balanced voltages, with the source delta-connected (the phase sequence, R-Y-B)**

**(b) Phasor diagram of the line and phase voltages**

$$E_{RY} = E \angle 0^\circ ; \quad E_{YB} = E \angle -120^\circ ; \quad E_{BR} = E \angle +120^\circ$$

If the phasor sum of the above three phase (or line) voltages are taken, the result is zero (0). The phase or line voltages form a balanced one, with their magnitudes being equal, and the phase being displaced from each other in sequence by  $120^\circ$ .



---

## Module - 3 : Transformers

---

**Contents:** Magnetic materials, BH characteristics, ideal and practical transformer, equivalent circuit, losses in transformers, regulation and efficiency. Auto-transformer and three-phase transformer connections.

---

### Classification of Magnetic Materials:

All materials can be classified in terms of their magnetic behavior falling into one of five categories depending on their bulk magnetic susceptibility. The two most common types of magnetism are diamagnetism and paramagnetism, which account for the magnetic properties of most of the periodic table of elements at room temperature.

**Diamagnetism:** In a diamagnetic material the atoms have no net magnetic moment when there is no applied field. Under the influence of an applied field ( $H$ ) the spinning electrons precess and this motion, which is a type of electric current, produces a magnetisation ( $M$ ) in the opposite direction to that of the applied field. All materials have a diamagnetic effect, however, it is often the case that the diamagnetic effect is masked by the larger paramagnetic or ferromagnetic term. The value of susceptibility is independent of temperature.

**Paramagnetism:** There are several theories of paramagnetism, which are valid for specific types of material. The Langevin model, which is true for materials with non-interacting localised electrons, states that each atom has a magnetic moment which is randomly oriented as a result of thermal agitation. The application of a magnetic field creates a slight alignment of these moments and hence a low magnetisation in the same direction as the applied field. As the temperature increases, then the thermal agitation will increase and it will become harder to align the atomic magnetic moments and hence the susceptibility will decrease. This behaviour is known as the Curie law.

**Ferromagnetism:** Ferromagnetism is only possible when atoms are arranged in a lattice and the atomic magnetic moments can interact to align parallel to each other. This effect is explained in classical theory by the presence of a molecular field within the ferromagnetic material, which was first postulated by Weiss in 1907. This field is sufficient to magnetise the material to saturation. In quantum mechanics, the Heisenberg model of ferromagnetism describes the parallel alignment of magnetic moments in terms of an exchange interaction between neighbouring moments. Weiss postulated the presence of magnetic domains within the material, which are regions where the atomic magnetic moments are aligned. The movement of these domains determines how the material responds to a magnetic field and as a consequence the susceptibility is a function of applied magnetic field. Therefore, ferromagnetic materials are usually compared in terms of saturation magnetisation (magnetisation when all domains are aligned) rather than susceptibility. In the periodic table of elements only Fe, Co and Ni are ferromagnetic at and above room temperature. As ferromagnetic materials are heated then the thermal agitation of the atoms means that the degree of alignment of the atomic magnetic moments decreases and hence the saturation magnetisation also decreases.

**Anti-ferromagnetism:** In the periodic table the only element exhibiting antiferromagnetism at room temperature is chromium. Antiferromagnetic materials are very similar to ferromagnetic materials but the exchange interaction between neighbouring atoms leads to the anti-parallel



alignment of the atomic magnetic moments. Therefore, the magnetic field cancels out and the material appears to behave in the same way as a paramagnetic material. Like ferromagnetic materials these materials become paramagnetic above a transition temperature, known as the Néel temperature,  $T_N$ . (Cr:  $T_N=37^\circ\text{C}$ ).

**Ferrimagnetism:** Ferrimagnetism is only observed in compounds, which have more complex crystal structures than pure elements. Within these materials the exchange interactions lead to parallel alignment of atoms in some of the crystal sites and anti-parallel alignment of others. The material breaks down into magnetic domains, just like a ferromagnetic material and the magnetic behaviour is also very similar, although ferrimagnetic materials usually have lower saturation magnetisations. For example in Barium ferrite ( $\text{BaO}\cdot 6\text{Fe}_2\text{O}_3$ ).

| Type                      | Example   | Atomic/Magnetic Behaviour   |  |  |
|---------------------------|---|---|--|--|
| <b>Diamagnetism</b>       | Inert gases; many metals eg Au, Cu, Hg; non-metallic elements e.g. B, Si, P, S; many ions e.g. $\text{Na}^+$ , $\text{Cl}^-$ & their salts; diatomic molecules e.g. $\text{H}_2$ , $\text{N}_2$ ; $\text{H}_2\text{O}$ ; most organic compounds | Atoms have no magnetic moment. Susceptibility is small & negative, $-10^{-6}$ to $-10^{-5}$                     |  |  |
| <b>Paramagnetism</b>      | Some metals, e.g. Al; some diatomic gases, e.g. $\text{O}_2$ , NO; ions of transition metals and rare earth metals, and their salts; rare earth oxides.   | Atoms have randomly oriented magnetic moments. Susceptibility is small & positive, $+10^{-5}$ to $+10^{-3}$     |  |  |
| <b>Ferromagnetism</b>     | Transition metals Fe, H, Co, Ni; rare earths with $64 \leq Z \leq 69$ ; alloys of ferromagnetic elements; some alloys of Mn, e.g. MnBi, $\text{Cu}_2\text{MnAl}$ .  | Atoms have parallel aligned magnetic moments. Susceptibility is large (below $T_c$ )                            |  |  |
| <b>Antiferromagnetism</b> | Transition metals Mn, Cr & many of their compound, e.g. MnO, CoO, NiO, $\text{Cr}_2\text{O}_3$ , MnS, MnSe, $\text{Cu}_2\text{O}$ .   | Atoms have anti-parallel aligned magnetic moments. Susceptibility is small & positive, $+10^{-5}$ to $+10^{-3}$ |  |  |
| <b>Ferrimagnetism</b>     | $\text{Fe}_3\text{O}_4$ (magnetite); $\gamma\text{-Fe}_2\text{O}_3$ (maghemite); mixed oxides of iron and other elements such as Sr ferrite.  | Atoms have mixed parallel and anti-parallel aligned magnetic moments. Susceptibility is large (below $T_c$ )    |  |  |

Table 2: A summary of the different types of magnetic behaviour.



**Magnetic hysteresis:**

1. Once magnetic saturation has been achieved, a decrease in the applied field back to zero results in a macroscopically permanent or residual magnetization, known as remanance,  $M_r$ . The corresponding induction,  $B_r$ , is called retentivity or remanent induction of the magnetic material. This effect of retardation by material is called hysteresis.
2. The magnetic field strength needed to bring the induced magnetization to zero is termed as coercivity,  $H_c$ . This must be applied anti-parallel to the original field.
3. A further increase in the field in the opposite direction results in a maximum induction in the opposite direction. The field can once again be reversed, and the field-magnetization loop can be closed, this loop is known as hysteresis loop or B-H plot or M- H plot.

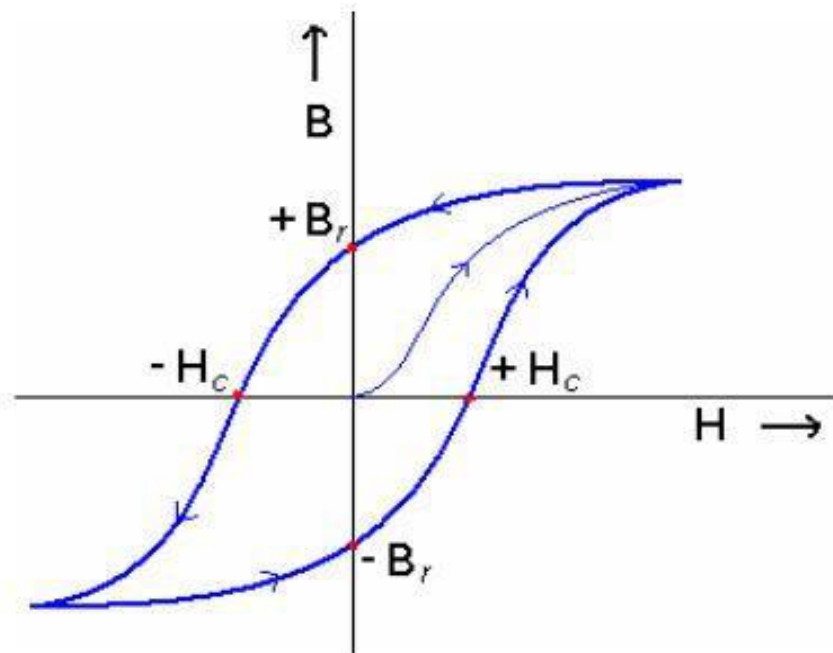

**Semi-hard magnets:**

- The area within the hysteresis loop represents the energy loss per unit volume of material for one cycle.
- The coercivity of the material is a micro-structure sensitive property. This dependence is known as magnetic shape anisotropy.
- The coercivity of recording materials needs to be smaller than that for others since data written onto a data storage medium should be erasable. On the other hand, the coercivity values should be higher since the data need to be retained. Thus such materials are called magnetically semi-hard.
- Ex.: Hard ferrites based on Ba, CrO<sub>2</sub>,  $\gamma$ -Fe<sub>2</sub>O<sub>3</sub>; alloys based on Co-Pt-Ta-Cr, Fe-Pt and Fe-Pd, etc.



**Soft magnets:**

1. Soft magnets are characterized by low coercive forces and high magnetic permeabilities; and are easily magnetized and de-magnetized.
2. They generally exhibit small hysteresis losses.
3. Application of soft magnets include: cores for electro-magnets, electric motors, transformers, generators, and other electrical equipment.
4. Ex.: ingot iron, low-carbon steel, Silicon iron, superalloy (80% Ni-5% Mo-Fe), 45 Permalloy (55%Fe-45%Ni), 2-79 Permalloy (79% Ni-4% Mo-Fe), MnZn ferrite / Ferroxcube A (48% MnFe<sub>2</sub>O<sub>4</sub>-52%ZnFe<sub>2</sub>O<sub>4</sub>), NiZn ferrite / Ferroxcube B (36% NiFe<sub>2</sub>O<sub>4</sub>-64% ZnFe<sub>2</sub>O<sub>4</sub>), etc.

**Hard magnets:**

1. Hard magnets are characterized by high remanent inductions and high coercivities. •These are also called permanent magnets or hard magnets.
2. These are found useful in many applications including fractional horse-power motors, automobiles, audio- and video- recorders, earphones, computer peripherals, and clocks.
3. They generally exhibit large hysteresis losses.
4. Ex.: Co-steel, Tungsten steel, SmCo<sub>5</sub>, Nd<sub>2</sub>Fe<sub>14</sub>B, ferrite Bao.6Fe<sub>2</sub>O<sub>3</sub>, Cunife (60% Cu 20% Ni-20% Fe), Alnico (alloy of Al, Ni, Co and Fe), etc

**TRANSFORMER:**

**Working principle of transformer:**

A Transformer is a static electrical device that transfers electrical energy between two or more circuits through electromagnetic induction. A varying current in one coil of the transformer produces a varying magnetic field, which in turn induces a varying electromotive force (e.m.f) or “voltage” in a second coil. Power can be transferred between the two coils through the magnetic field, without a metallic connection between the two circuits. Faraday’s law of induction discovered in 1831 described this effect. Transformers are used to increase or decrease the alternating voltages in electric power applications.

Since the invention of the first constant-potential transformer in 1885, transformers have become essential for the transmission, distribution, and utilization of alternating current electrical energy. A wide range of transformer design is encountered in electronic and electric power applications.



**E.M.F Equation of Transformer:**

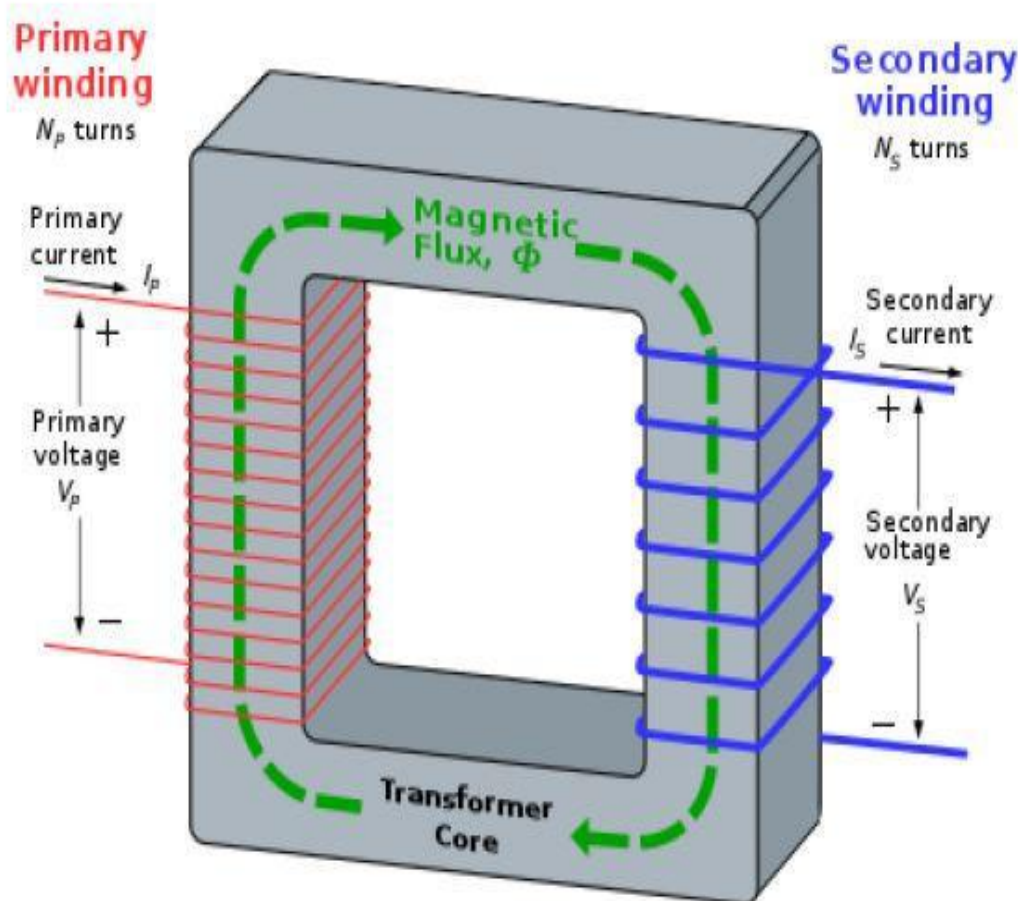

The primary winding draws a current when it is connected to an alternating voltage source this sinusoidal current produces a sinusoidal flux  $\Phi$  that can be expressed as:



$$\phi = \phi_m \sin \omega t \quad \dots\dots(1)$$

Instantaneous emf induced in the primary winding is:

$$e_1 = -N_1 \frac{d\phi}{dt} \quad \dots\dots(2)$$

Similarly, instantaneous emf induced in the secondary winding is:

$$e_2 = -N_2 \frac{d\phi}{dt} \quad \dots\dots(3)$$

Substituting eq.(1) in (2) yields ,

$$e_1 = -N_1 \frac{d}{dt} (\phi_m \sin \omega t) \quad \dots\dots(4)$$

$$e_1 = -N_1 \omega \phi_m \cos \omega t \quad \dots\dots(5)$$

$$e_1 = -N_1 \omega \phi_m \sin(\omega t - 90) \quad \dots\dots(6)$$

The maximum value of  $e_1$  is:

$$E_{m1} = N_1 \omega \phi_m \quad \dots\dots(7)$$

The rms value of the primary emf is:

$$E_1 = \frac{E_{m1}}{\sqrt{2}} \quad \dots\dots(8)$$

Substituting eq.(7) into eq.(8) yields,

$$E_1 = \frac{N_1 2\pi f \phi_m}{\sqrt{2}} \quad \dots\dots(9)$$

$$E_1 = 4.44 \phi_m N_1 \quad \dots\dots(10)$$

---





Similarly the expression of the secondary emf is:

$$E_2 = 4.44\phi_m N_2 \quad \dots\dots(11)$$

The primary and secondary voltage can be determined from eq. (10) and (11) if other parameters are known.

**Turns ratio of transformer:**

Turns ratio is an important parameters for drawing an equivalent circuit of a transformer. The turn ratio is used to identify the step-up and step-down transformers. According to Faraday’s law, the induced emf in the primary (e1) and the secondary (e2) winding are:

$$e_1 = -N_1 \frac{d\phi}{dt} \quad \dots\dots(12)$$

$$e_2 = -N_2 \frac{d\phi}{dt} \quad \dots\dots(13)$$

Dividing eq.(12) by eq.(11)

$$\frac{e_1}{e_2} = \frac{N_1}{N_2} \quad \dots\dots(14)$$

$$\frac{e_1}{e_2} = \frac{N_1}{N_2} = a \quad \dots\dots(15)$$

Similarly, dividing eq.(10) by eq.(11) yields,

$$\frac{E_1}{E_2} = \frac{N_1}{N_2} = a \quad \dots\dots(16)$$

Where a is the turns ratio of a transformer.

In case of  $N_2 > N_1$  , The transformer is called a step-up transformer, whereas for  $N_1 > N_2$ , the transformer is called a step-down transformer. The losses are zero in an ideal transformer. In this case, the input power of the transformer is equal to output power and this yields,

$$V_1 I_1 = V_2 I_2 \quad \dots\dots(17)$$

Eq.(17) can be rearranged as :

$$\frac{V_1}{V_2} = \frac{I_2}{I_1} = a \quad \dots\dots(18)$$

The ratio of primary current to the secondary current is:

$$\frac{I_1}{I_2} = \frac{1}{a} \quad \dots\dots(19)$$



Again , the magneto motive force produced by the primary current will be equal to the magneto motive force produced by the secondary current and it can be expressed as:

$$N_1 I_1 = N_2 I_2 \quad \dots\dots\dots(21)$$

$$\frac{I_1}{I_2} = \frac{N_2}{N_1} = \frac{1}{a} \quad \dots\dots\dots(22)$$

From eq.(22) it is concluded that the ratio of primary to secondary current is inversely proportional to the turns ratio of the transformer.

The input and output power of an ideal transformer is:

$$P_{in} = V_1 I_1 \cos \phi_1 \quad \dots\dots\dots(23)$$

$$P_{out} = V_2 I_2 \cos \phi_2 \quad \dots\dots\dots(24)$$

For an ideal condition, the angle  $\phi_1$  is equal to the angle  $\phi_2$  and output power can be re-arranged as,

$$P_{out} = \frac{V_1}{a} a I_1 \cos \phi_1 \quad \dots\dots\dots(25)$$

$$P_{out} = V_1 I_1 \cos \phi_1 = P_{in} \quad \dots\dots\dots(26)$$

From eq.(26), it is seen that the input and output power are the same in case of an ideal transformer , similarly the input and the output reactive power are:

$$Q_{out} = V_2 I_2 \sin \phi_2 = V_1 I_1 \sin \phi_1 = Q_{in} \quad \dots\dots\dots(27)$$

From eq.(26) and eq.(27), the input and output power and reactive power can be calculated if other parameter are known .

**Ideal transformer and it's characteristics:**

An ideal transformer is an imaginary transformer which has

- no copper losses (no winding resistance)
- no iron loss in core
- no leakage flux

In other words, an ideal transformer gives output power exactly equal to the input power. The efficiency of an idea transformer is 100%. Actually, it is impossible to have such a transformer in practice, but ideal transformer model makes problems easier.

**Characteristics of ideal transformer:**

- **Zero winding resistance:** It is assumed that, resistance of primary as well as secondary winding of an ideal transformer is zero. That is, both the coils are purely inductive in nature.
- **Infinite permeability of the core:** Higher the permeability, lesser the mmf required for flux establishment. That means, if permeability is high, less magnetizing current is required to magnetize the transformer core.



- **No leakage flux:** Leakage flux is a part of magnetic flux which does not get linked with secondary winding. In an ideal transformer, it is assumed that entire amount of flux get linked with secondary winding (that is, no leakage flux).
- **100% efficiency:** An ideal transformer does not have any losses like hysteresis loss, eddy current loss etc. So, the output power of an ideal transformer is exactly equal to the input power. Hence, 100% efficiency.

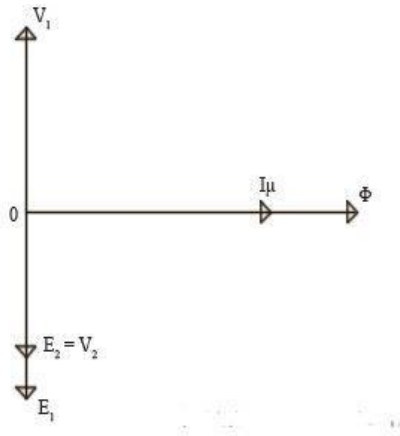

Fig. Transformer is unloaded.

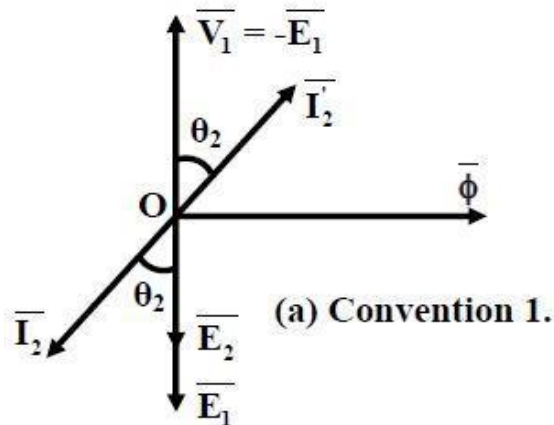

Fig. Transformer is loaded.

Now, if an alternating voltage  $V_1$  is applied to the primary winding of an ideal transformer, counter emf  $E_1$  will be induced in the primary winding. As windings are purely inductive, this induced emf  $E_1$  will be exactly equal to the apply voltage but in 180 degree phase opposition. Current drawn from the source produces required magnetic flux. Due to primary winding being purely inductive, this current lags  $90^\circ$  behind induced emf  $E_1$ . This current is called magnetizing current of the transformer  $I_\mu$ . This magnetizing current  $I_\mu$  produces alternating magnetic flux  $\Phi$ . This flux  $\Phi$  gets linked with the secondary winding and emf  $E_2$  gets induced by mutual induction. This mutually induced emf  $E_2$  is in phase with  $E_1$ . If closed circuit is provided at secondary winding,  $E_2$  causes current  $I_2$  to flow in the circuit.

$$\text{For an ideal transformer, } E_1 I_1 = E_2 I_2$$



**Transformer with resistance and leakage reactance:**

**Magnetic leakage**

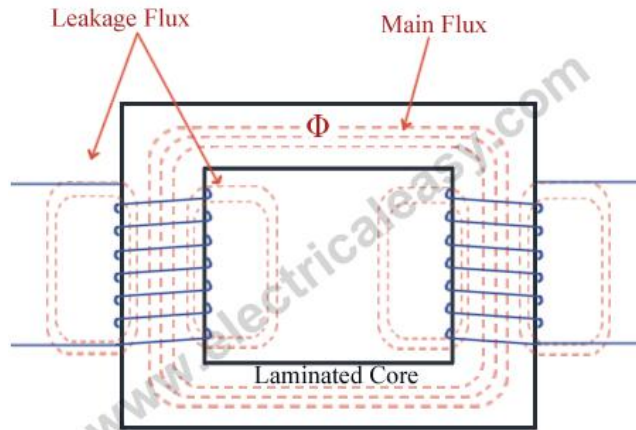

In a transformer it is observed that, all the flux linked with primary winding does not get linked with secondary winding. A small part of the flux completes its path through air rather than through the core (as shown in the fig at right), and this small part of flux is called as leakage flux or magnetic leakage in transformers. This leakage flux does not link with both the windings, and hence it does not contribute to transfer of energy from primary winding to secondary winding. But, it produces self induced emf in each winding. Hence, leakage flux produces an effect equivalent to an inductive coil in series with each winding. And due to this there will be leakage reactance.

(To minimize this leakage reactance, primary and secondary windings are not placed on separate legs, refer the diagram of core type and shell type transformer from construction of transformer.)

**Practical Transformer with resistance and leakage reactance**

In the following figure, leakage reactance and resistance of the primary winding as well as secondary winding are taken out, representing a practical transformer.

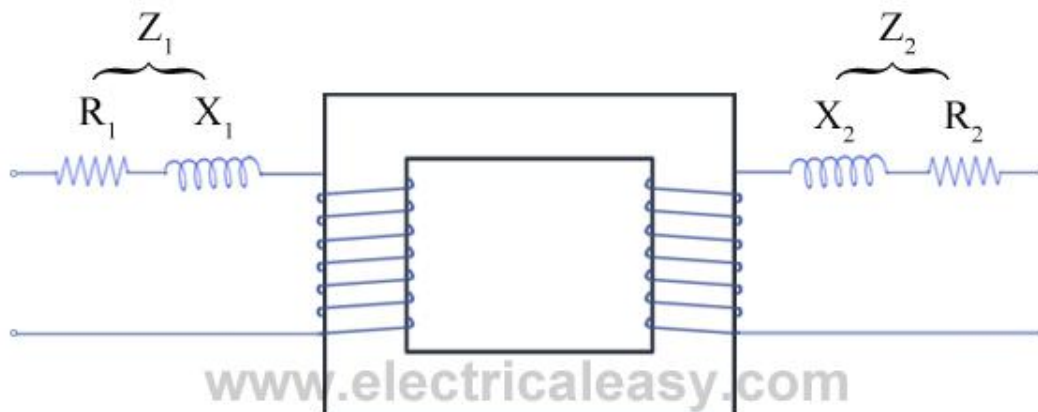



Where,  $R_1$  and  $R_2$  = resistance of primary and secondary winding respectively.

$X_1$  and  $X_2$  = leakage reactance of primary and secondary winding resp.

$Z_1$  and  $Z_2$  = Primary impedance and secondary impedance resp.

$Z_1 = R_1 + jX_1$  ...and  $Z_2 = R_2 + jX_2$  .

The impedance in each winding lead to some voltage drop in each winding. Considering this voltage drop the voltage equation of transformer can be given as -

$V_1 = E_1 + I_1(R_1 + jX_1)$  -----primary side

$V_2 = E_2 - I_2(R_2 + jX_2)$  -----secondary side

where,  $V_1$  = supply voltage of primary winding

$V_2$  = terminal voltage of secondary winding

$E_1$  and  $E_2$  = induced emf in primary and secondary winding respectively. (EMF equation of a transformer.)

**Equivalent circuit of transformer:**

In a practical transformer –

(a) Some leakage flux is present at both primary and secondary sides. This leakage gives rise to leakage reactances at both sides, which are denoted as  $X_1$  and  $X_2$  respectively.

(b) Both the primary and secondary winding possesses resistance, denoted as  $R_1$  and  $R_2$  respectively. These resistances causes voltage drop as,  $I_1R_1$  and  $I_2R_2$  and also copper loss  $I_1^2R_1$  and  $I_2^2R_2$ .

(c) Permeability of the core can not be infinite, hence some magnetizing current is needed. Mutual flux also causes core loss in iron parts of the transformer.

We need to consider all the above things to derive equivalent circuit of a transformer.

Resistances and reactances of transformer, which are described above, can be imagined separately from the windings (as shown in the figure below). Hence, the function of windings, thereafter, will only be the transforming the voltage.

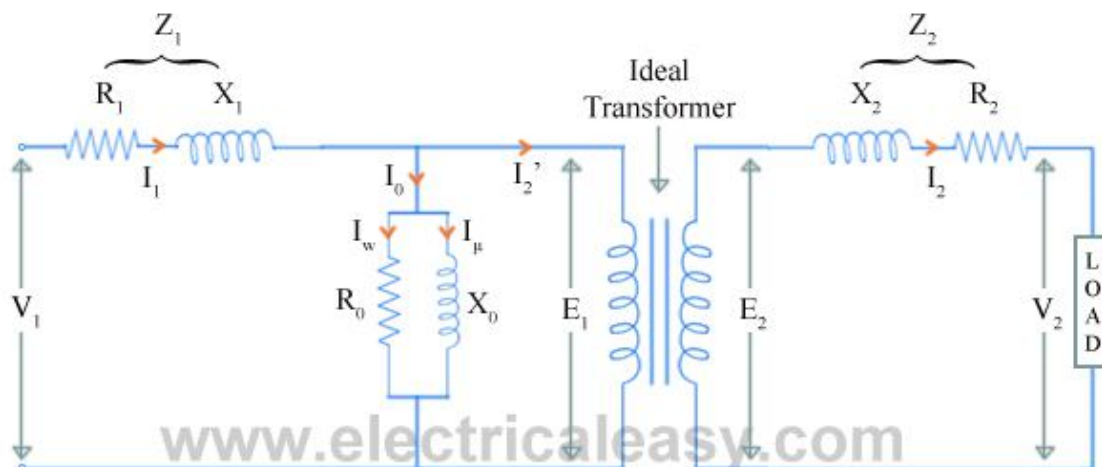



The no load current  $I_0$  is divided into, pure inductance  $X_0$  (taking magnetizing components  $I_\mu$ ) and non inductive resistance  $R_0$  (taking working component  $I_w$ ) which are connected into parallel across the primary. The value of  $E_1$  can be obtained by subtracting  $I_1 Z_1$  from  $V_1$ . The value of  $R_0$  and  $X_0$  can be calculated as,  $R_0 = E_1 / I_w$  and  $X_0 = E_1 / I_\mu$ .

But, using this equivalent circuit does not simplify the calculations. To make calculations simpler, it is preferable to transfer current, voltage and impedance either to primary side or to the secondary side. In that case, we would have to work with only one winding which is more convenient.

From the voltage transformation ratio, it is clear that,

$$E_1 / E_2 = N_1 / N_2 = K$$

Now, let's refer the parameters of secondary side to primary.

$Z_2$  can be referred to primary as  $Z_2'$

where,  $Z_2' = (N_1/N_2)^2 Z_2 = K^2 Z_2$ . .....where  $K = N_1/N_2$ .

that is,  $R_2' + jX_2' = K^2(R_2 + jX_2)$

equating real and imaginary parts,

$$R_2' = K^2 R_2 \text{ and } X_2' = K^2 X_2 .$$

$$\text{And } V_2' = K V_2$$

The following figure shows the **equivalent circuit of transformer with secondary parameters referred to the primary.**

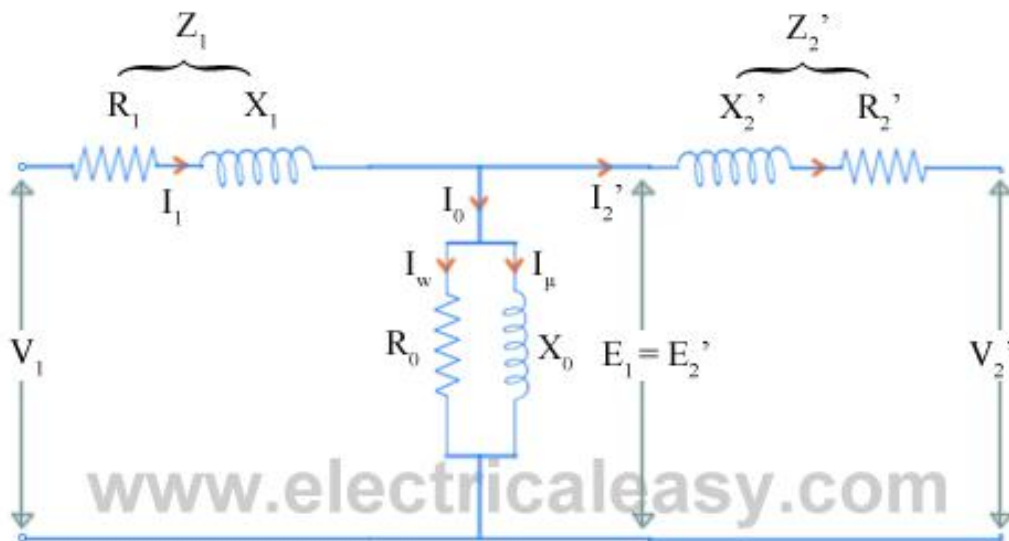

Now, as the values of winding resistance and leakage reactance are so small that,  $V_1$  and  $E_1$  can be assumed to be equal. Therefore, the exciting current drawn by the parallel combination of  $R_0$  and  $X_0$  would not affect significantly, if we move it to the input terminals as shown in the figure below.

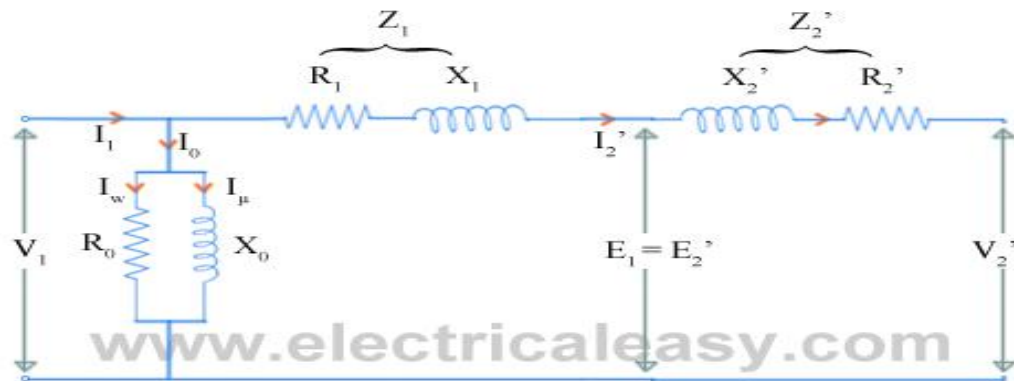

Now, let  $R_1 + R_2' = R'_{eq}$  and  $X_1 + X_2' = X'_{eq}$

Then the **equivalent circuit of transformer** becomes as shown in the figure below

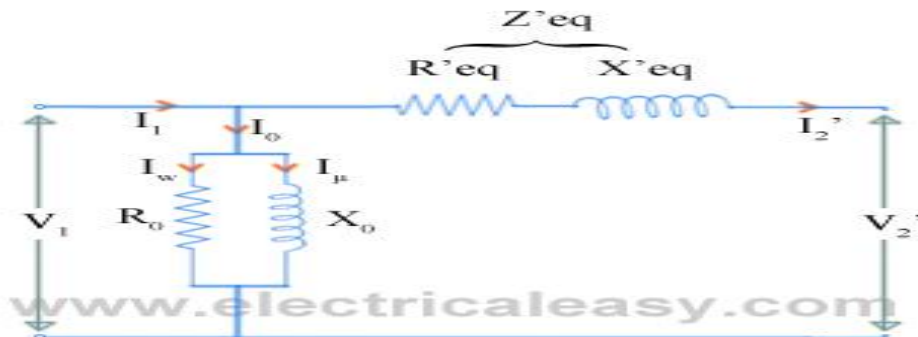

**Approximate equivalent circuit of transformer:**

If only voltage regulation is to be calculated, then even the whole excitation branch (parallel combination of  $R_0$  and  $X_0$ ) can be neglected. Then the equivalent circuit becomes as shown in the figure below.

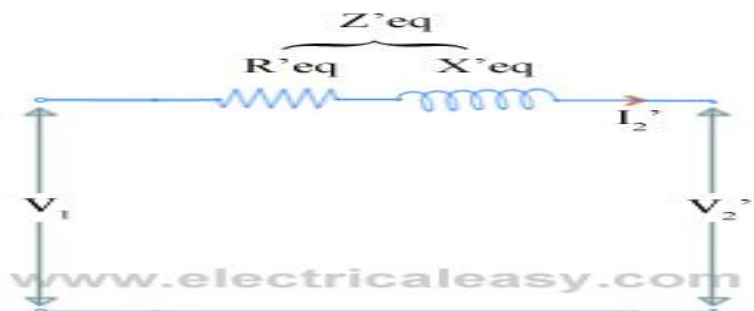

**Transformer - Losses and Efficiency:**

**Losses in transformer:**

In any electrical machine, 'loss' can be defined as the difference between input power and output power. An electrical transformer is a static device, hence mechanical losses (like windage or friction losses) are absent in it. A transformer only consists of electrical losses (iron losses



and copper losses). Transformer losses are similar to losses in a DC machine, except that transformers do not have mechanical losses.

### (i) Core losses or Iron losses:

Eddy current loss and hysteresis loss depend upon the magnetic properties of the material used for the construction of core. Hence these losses are also known as **core losses** or **iron losses**.

- **Hysteresis loss in transformer:** Hysteresis loss is due to reversal of magnetization in the transformer core. This loss depends upon the volume and grade of the iron, frequency of magnetic reversals and value of flux density. It can be given by, Steinmetz formula:  
$$W_h = \eta B_{\max}^{1.6} fV \text{ (watts)}$$
where,  $\eta$  = Steinmetz hysteresis constant  
 $V$  = volume of the core in  $m^3$
- **Eddy current loss in transformer:** In transformer, AC current is supplied to the primary winding which sets up alternating magnetizing flux. When this flux links with secondary winding, it produces induced emf in it. But some part of this flux also gets linked with other conducting parts like steel core or iron body or the transformer, which will result in induced emf in those parts, causing small circulating current in them. This current is called as eddy current. Due to these eddy currents, some energy will be dissipated in the form of heat.

### (ii) Copper loss in transformer

Copper loss is due to ohmic resistance of the transformer windings. Copper loss for the primary winding is  $I_1^2 R_1$  and for secondary winding is  $I_2^2 R_2$ . Where,  $I_1$  and  $I_2$  are current in primary and secondary winding respectively,  $R_1$  and  $R_2$  are the resistances of primary and secondary winding respectively. It is clear that Cu loss is proportional to square of the current, and current depends on the load. Hence copper loss in transformer varies with the load.

#### Efficiency of Transformer

Just like any other electrical machine, **efficiency of a transformer** can be defined as the output power divided by the input power. That is efficiency = output / input .

Transformers are the most highly efficient electrical devices. Most of the transformers have full load efficiency between 95% to 98.5% . As a transformer being highly efficient, output and input are having nearly same value, and hence it is impractical to measure the efficiency of transformer by using output / input. A better method to find efficiency of a transformer is using,

$$\text{efficiency} = (\text{input} - \text{losses}) / \text{input} = 1 - (\text{losses} / \text{input}).$$

#### Condition for maximum efficiency

Let,

$$\text{Copper loss} = I_1^2 R_1$$

$$\text{Iron loss} = W_i$$





$$\text{efficiency} = 1 - \frac{\text{losses}}{\text{input}} = 1 - \frac{I_1^2 R_1 + W_i}{V_1 I_1 \cos \Phi_1}$$

$$\eta = 1 - \frac{I_1 R_1}{V_1 \cos \Phi_1} - \frac{W_i}{V_1 I_1 \cos \Phi_1}$$

differentiating above equation with respect to  $I_1$

$$\frac{d\eta}{dI_1} = 0 - \frac{R_1}{V_1 \cos \Phi_1} + \frac{W_i}{V_1 I_1^2 \cos \Phi_1}$$

$$\eta \text{ will be maximum at } \frac{d\eta}{dI_1} = 0$$

Hence efficiency  $\eta$  will be maximum at

$$\frac{R_1}{V_1 \cos \Phi_1} = \frac{W_i}{V_1 I_1^2 \cos \Phi_1}$$

$$\frac{I_1^2 R_1}{V_1 I_1^2 \cos \Phi_1} = \frac{W_i}{V_1 I_1^2 \cos \Phi_1}$$

$$I_1^2 R_1 = W_i \quad \text{electricaleasy.com}$$

Hence, **efficiency of a transformer** will be maximum when copper loss and iron losses are equal.

That is Copper loss = Iron loss.

### **Voltage Regulation of Transformer:**

Voltage regulation is a measure of change in the voltage magnitude between the sending and receiving end of a component. It is commonly used in power engineering to describe the percentage voltage difference between no load and full load voltages distribution lines, transmission lines, and transformers.

**Explanation of Voltage Regulation of Transformer:** An electrical power transformer is open circuited, meaning that the load is not connected to the secondary terminals. In this situation, the secondary terminal voltage of the transformer will be its secondary induced emf  $E_2$ . Whenever a full load is connected to the secondary terminals of the transformer, rated current



$I_2$  flows through the secondary circuit and voltage drop comes into picture. At this situation, primary winding will also draw equivalent full load current from source. The voltage drop in the secondary is  $I_2 Z_2$  where  $Z_2$  is the secondary impedance of transformer. Now if at this loading condition, any one measures the voltage between secondary terminals, he or she will get voltage  $V_2$  across load terminals which is obviously less than no load secondary voltage  $E_2$  and this is because of  $I_2 Z_2$  voltage drop in the transformer.

## Expression of Voltage Regulation of Transformer

The equation for the **voltage regulation of transformer**, represented in percentage, is

$$\text{Voltage regulation}(\%) = \frac{E_2 - V_2}{V_2} \times 100\%$$

## Voltage Regulation of Transformer for Lagging Power Factor

$$\begin{aligned} \text{Voltage regulation} (\%) &= \frac{E_2 - V_2}{V_2} \times 100(\%) \\ &= \frac{I_2 R_2 \cos \theta_2 + I_2 X_2 \sin \theta_2}{V_2} \times 100(\%) \end{aligned}$$

## Voltage Regulation of Transformer for Leading Power Factor

$$\begin{aligned} \text{Voltage regulation} (\%) &= \frac{E_2 - V_2}{V_2} \times 100(\%) \\ &= \frac{I_2 R_2 \cos \theta_2 - I_2 X_2 \sin \theta_2}{V_2} \times 100(\%) \end{aligned}$$

## Zero Voltage Regulation of a Transformer

'Zero voltage regulation' indicates that there is no difference between its 'no-load voltage' and its 'full-load voltage'. This means that in the voltage regulation equation above, voltage regulation is equal to zero. This is not practical – and is only theoretically possible in the case for an ideal transformer.

## Auto transformer:

An **auto transformer** is an electrical transformer having only one winding. The winding has at least three terminals which is explained in the construction details below.

Some of the **advantages of auto-transformer** are that,

- they are smaller in size,
- cheap in cost,
- low leakage reactance,
- increased kVA rating,
- low exciting current etc.



An example of **application of auto transformer** is, using an US electrical equipment rated for 115 V supply (they use 115 V as standard) with higher Indian voltages. Another example could be in starting method of three phase induction motors.

### Construction of auto transformer

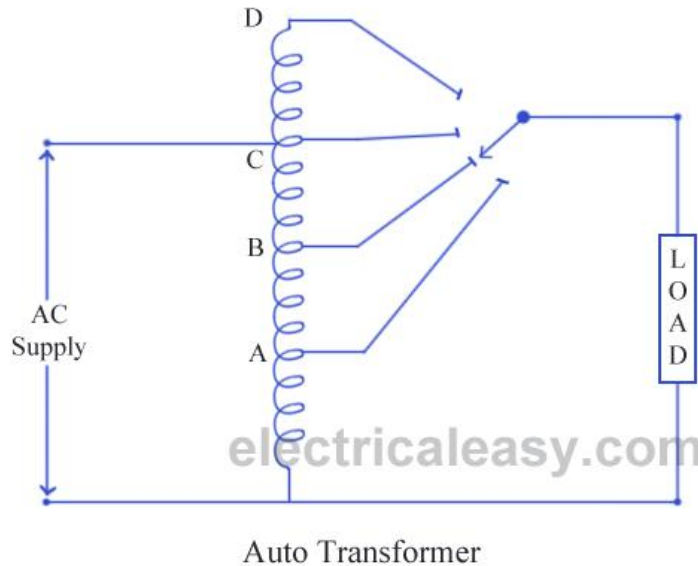

An auto transformer consists of a single copper wire, which is common in both primary as well as secondary circuit. The copper wire is wound a laminated silicon steel core, with at least three tappings taken out. Secondary and primary circuit share the same neutral point of the winding. The construction is well explained in the diagram. Variable turns ratio at secondary can be obtained by the tappings of the winding (as shown in the figure), or by providing a smooth sliding brush over the winding. Primary terminals are fixed. Thus, in an auto transformer, you may say, primary and secondary windings are connected magnetically as well as electrically.

### Working of auto transformer:

As I have described just above, an auto transformer has only one winding which is shared by both primary and secondary circuit, where number of turns shared by secondary are variable. EMF induced in the winding is proportional to the number of turns. Therefore, the secondary voltage can be varied by just varying secondary number of turns.

As winding is common in both circuits, most of the energy is transferred by means of electrical conduction and a small part is transferred through induction.

The considerable **disadvantages of an auto transformer** are,

- any undesirable condition at primary will affect the equipment at secondary (as windings are not electrically isolated),
- due to low impedance of auto transformer, secondary short circuit currents are very high,
- harmonics generated in the connected equipment will be passed to the supply.



### Three Phase Transformer Connections:

Three phase transformer connections In three phase system, the three phases can be connected in either star or delta configuration. In case you are not familiar with those configurations, study the following image which explains star and delta configuration. In any of these configurations, there will be a phase difference of  $120^\circ$  between any two phases.

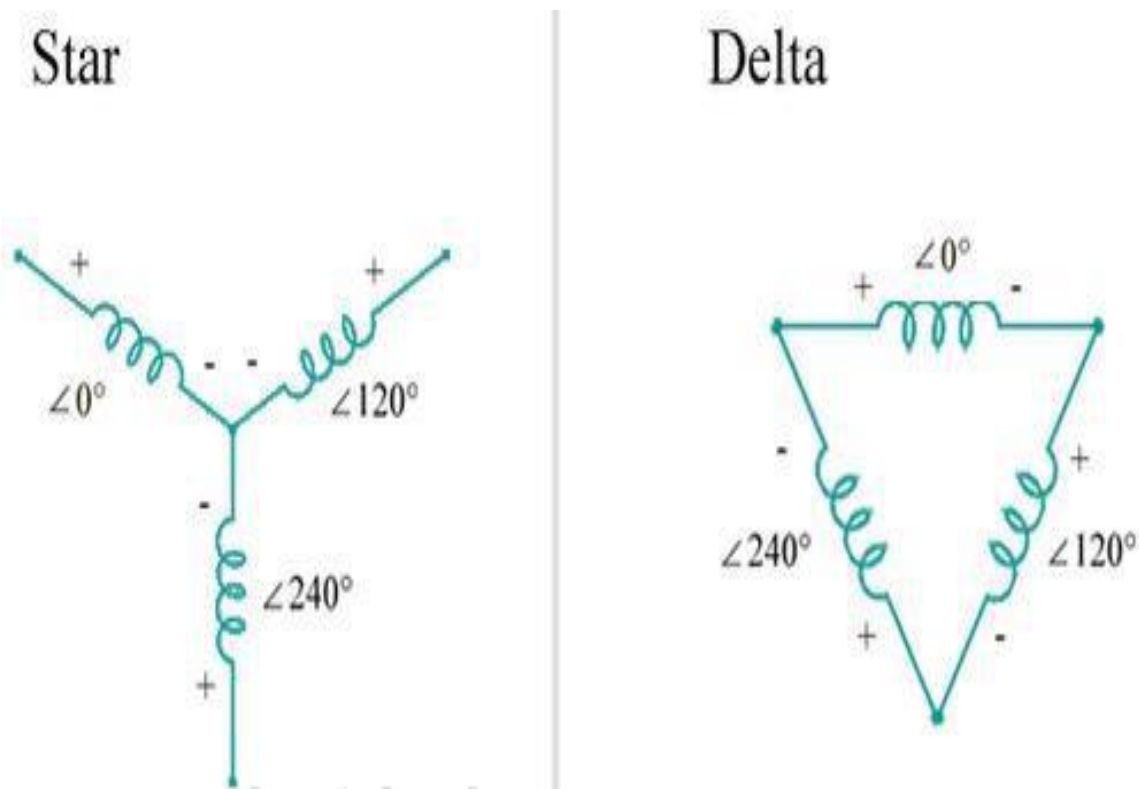

### Three phase transformer connections

Windings of a three phase transformer can be connected in various configurations as (i) star-star, (ii) delta-delta, (iii) star-delta, (iv) delta-star, These configurations are explained below.

#### Star-star (Y-Y)

- Star-star connection is generally used for small, high-voltage transformers. Because of star connection, number of required turns/phase is reduced (as phase voltage in star connection is  $1/\sqrt{3}$  times of line voltage only). Thus, the amount of insulation required is also reduced.
- The ratio of line voltages on the primary side and the secondary side is equal to the transformation ratio of the transformers.
- Line voltages on both sides are in phase with each other.



- This connection can be used only if the connected load is balanced.

#### **Delta-delta ( $\Delta$ - $\Delta$ )**

- This connection is generally used for large, low-voltage transformers. Number of required phase/turns is relatively greater than that for star-star connection.
- The ratio of line voltages on the primary and the secondary side is equal to the transformation ratio of the transformers.
- This connection can be used even for unbalanced loading.
- Another advantage of this type of connection is that even if one transformer is disabled, system can continue to operate in open delta connection but with reduced available capacity.

#### **Star-delta OR wye-delta ( $Y$ - $\Delta$ )**

- The primary winding is star star ( $Y$ ) connected with grounded neutral and the secondary winding is delta connected.
- This connection is mainly used in step down transformer at the substation end of the transmission line.
- The ratio of secondary to primary line voltage is  $1/\sqrt{3}$  times the transformation ratio.
- There is  $30^\circ$  shift between the primary and secondary line voltages.

#### **Delta-star OR delta-wye ( $\Delta$ - $Y$ )**

- The primary winding is connected in delta and the secondary winding is connected in star with neutral grounded. Thus it can be used to provide 3-phase 4-wire service.
- This type of connection is mainly used in step-up transformer at the beginning of transmission line.
- The ratio of secondary to primary line voltage is  $\sqrt{3}$  times the transformation ratio.
- There is  $30^\circ$  shift between the primary and secondary line voltages.

Above transformer connection configurations are shown in the following figure.

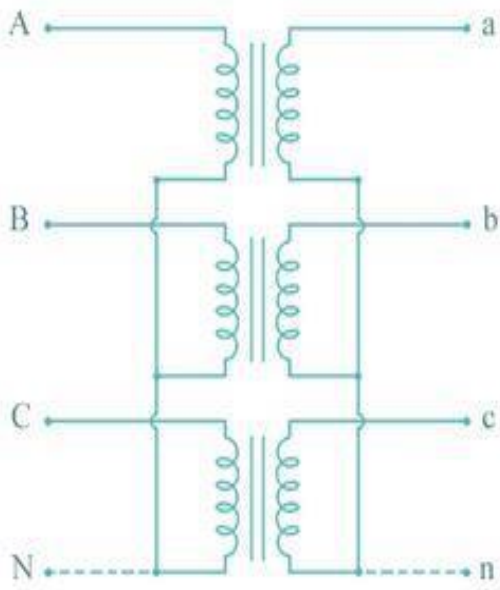

**Y - Y**

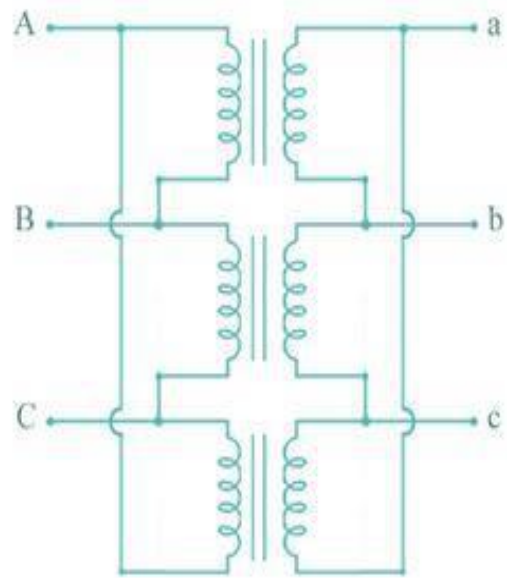

**Δ - Δ**

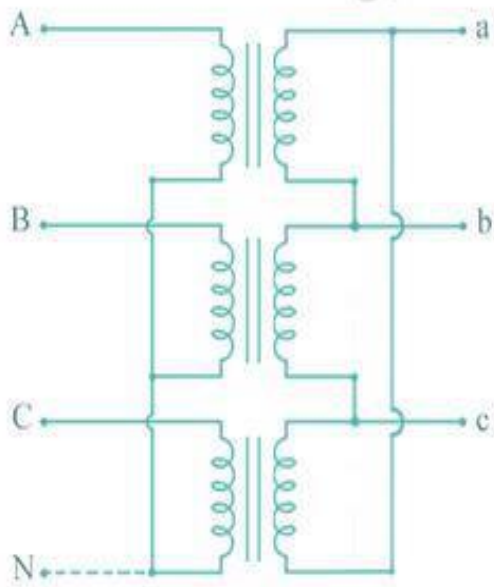

**Y - Δ**

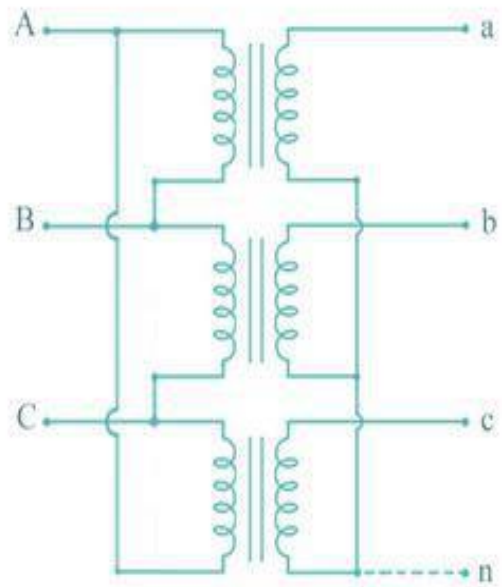

**Δ - Y**



## MODULE 4: Electrical Machines

**Contents:** DC machines: Principle & Construction, Types, EMF equation of generator and torque equation of motor, applications of DC motors (simple numerical problems) Three Phase Induction Motor: Principle & Construction, Types, Slip-torque characteristics, Applications (Numerical problems related to slip only) Single Phase Induction motor: Principle of operation and introduction to methods of starting, applications. Three Phase Synchronous Machines: Principle of operation of alternator and synchronous motor and their applications.

### Construction of DC Machine:-

DC Generator:- Electrical machine which converts mechanical energy into electrical energy.

DC Motor: - Electrical machine which converts electrical energy into mechanical energy.

A DC machine consists of two basic parts; stator and rotor. Basic constructional parts of a DC machine are described below.

Stator is the stationary part of the machine and rotor is the rotator part of the machine

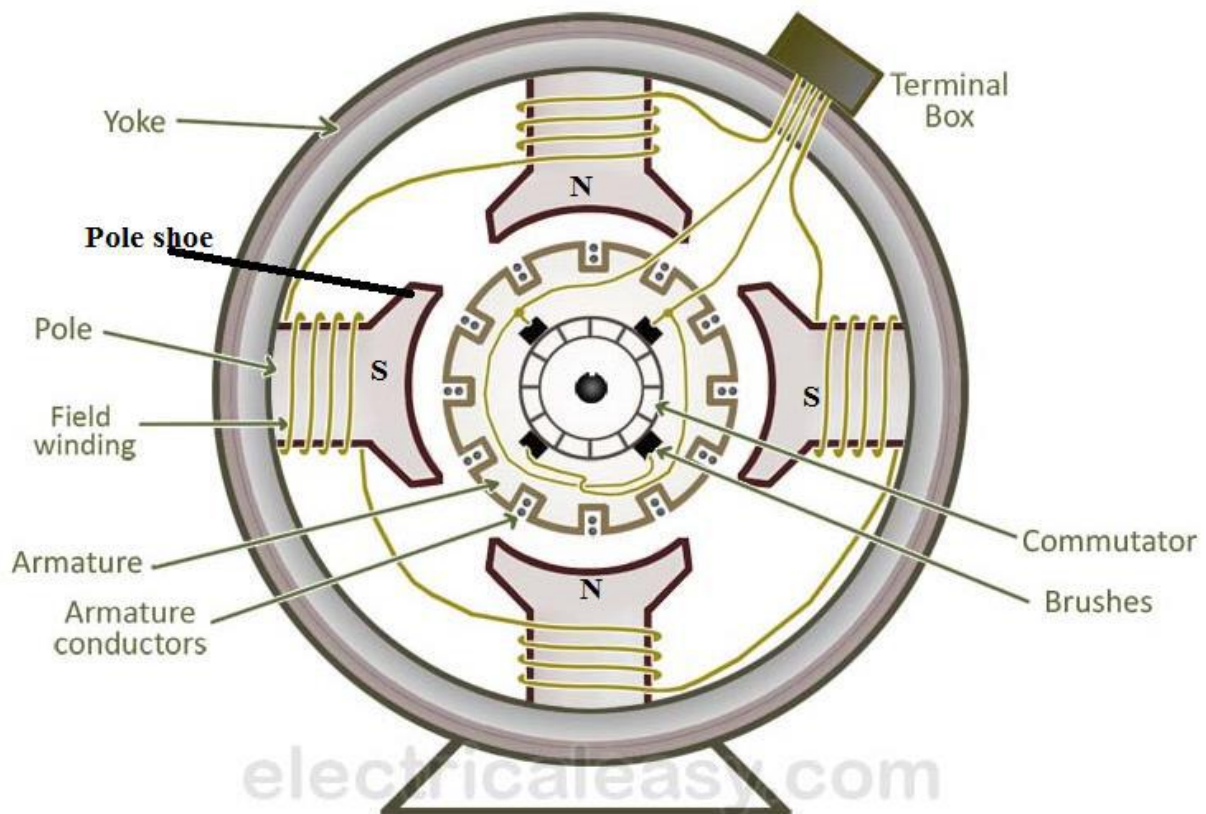

**Yoke or Magnetic frame:** The outer frame of a dc machine is called as yoke. It is made up of cast iron or steel. Yoke serve two purposes, firstly it provides mechanical protection to the outer parts of the machine secondly it provides low reluctance path for the magnetic flux.



**Poles and pole shoes:** The pole and pole shoe are fixed on the yoke by bolts.. They carry field winding and pole shoes are fastened to them. Pole shoes serve two purposes; (i) they support field coils and (ii) spread out the flux in air gap uniformly.

**Field winding:** They are usually made of copper. Field coils are former wound and placed on each pole and are connected in series. They are wound in such a way that, when energized, they form alternate North and South poles.

**Armature core:** Armature core is the rotor of a dc machine. It is cylindrical in shape with slots to carry armature winding. The armature is built up of thin laminated circular steel disks for reducing eddy current losses. It may be provided with air ducts for the axial air flow for cooling purposes. Armature is keyed to the shaft.

**Armature winding:** It is usually a former wound copper coil which rests in armature slots. The armature conductors are insulated from each other and also from the armature core. Armature winding can be wound by one of the two methods; lap winding or wave winding. Double layer lap or wave windings are generally used.

**Commutator :** Physical connection to the armature winding is made through a commutator-brush arrangement. The function of a commutator, in a dc machine

1. It provides link between rotating armature conductor and stationary electrical circuit by brushes.
2. It converts alternating current produced in armature conductors to a unidirectional current in the external load circuit.

A commutator consists of a set of copper segments which are insulated from each other. The number of segments is equal to the number of armature coils. Each segment is connected to an armature coil and the commutator is keyed to the shaft.

**Brushes:-** Brushes are usually made from carbon or graphite. They rest on commutator segments and slide on the segments when the commutator rotates keeping the physical contact to collect or supply the current.

### EMF EQUATION OF D.C. MACHINE :-

Let

$\phi$  = flux per pole

P = Total no. of poles





Z = Total number of active conductors on the armature

A = No. of parallel paths in the armature winding

For Lap Winding:-- A = P, Wave Winding: -- A = 2

N = speed of rotation of the armature in rpm(revolution per minute)

$\omega_m$  = speed in radians per second

When the rotor rotates in the field a voltage is developed in the armature.

The flux cut by one conductor in one rotation =  $P\phi$

Time taken to complete one revolution =  $\frac{N}{60}$

According to faraday's law of electromagnetic induction, emf induced is given by: -  $E = \frac{d\phi}{dt}$

Hence emf induced by one conductor is given by: -  $E = \frac{P\phi N}{60}$

Total Z no. of conductor connected in series with A parallel path =  $\frac{Z}{A}$

Total emf induced is given by :-  $E = \frac{P\phi ZN}{60A}$

$$E \propto \phi N \quad E = k\phi N \quad \text{Here } k = \frac{PZ}{60A}$$

### **Torque equation of dc machine:-**

Electrical input= Mechanical output

$$E.I_a = \omega.T$$

Here E=Input voltage,  $I_a$  =Armature current,

$\omega$ =Angular velocity( $\omega=2\pi n/60$ ), T=Torque

$$T = E.I_a / \omega \quad \text{-----(1)}$$

Because  $E = P\phi ZN / 60.a$  and  $\omega = 2\pi n / 60$

Put the value of E and  $\omega$  in equation (1), We get

$$T = \frac{\frac{P\phi ZN}{60.a} . I_a}{\frac{2\pi n}{60.a}} = \frac{P\phi Z I_a}{2\pi a}$$

$$\text{Here } K = \frac{PZ}{2\pi a}$$

$$T \propto \phi I_a$$



### Classification of DC generator:-

DC generators are classified based on their method of excitation. So on this basis there are two types of DC generators:-

1. Separately excited DC generator
2. Self-excited DC generator

Self-excited DC generator can again be classified as

- 1) DC Series generator
- 2) DC Shunt generator
- 3) DC Compound generator.

**1) Separately excited DC generator:** - Dc generator has a field magnet winding which is excited using a separate voltage source (like battery). You can see the representation in the below image. The output voltage depends on the speed of rotation of armature and field current. The higher the speed of rotation and current – the higher the output e.m.f.

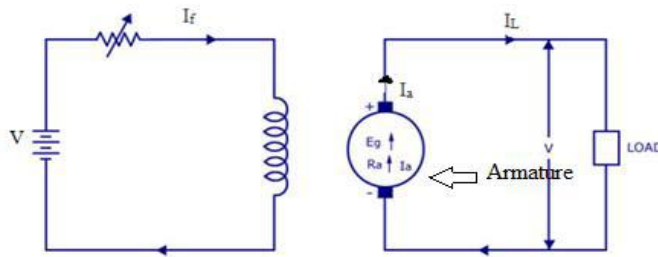

### 2. Self Excited DC Generator

These are generators in which the field winding is excited by the output of the generator itself. As described before – there are three types of self-excited dc generators – they are

- 1) Series
- 2) Shunt
- 3) Compound.

1. **Series DC Generator:-**A series DC generator is shown below in fig (a) – in which the armature winding is connected in series with the field winding so that the field current flows through the load as well as the field winding. The field winding is a low resistance, thick wire of few turns. Series generators are also rarely used.

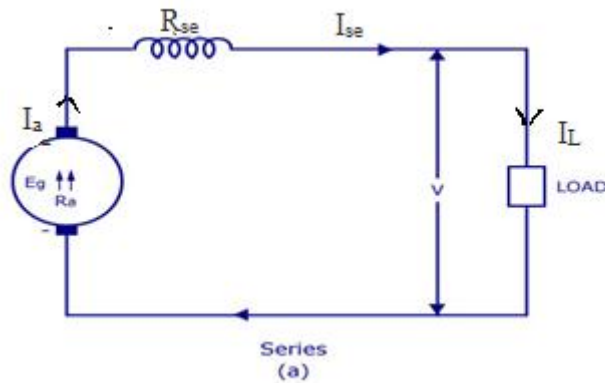

Here  $I_a = I_{se} = I_L$

The output voltage is given by:  $-V = E_g - I_a \cdot R_a - I_a \cdot R_{se}$

$$V = E_g - I_a \cdot (R_a + R_{se})$$

2. **Shunt DC Generator**:- A shunt DC generator is shown in figure (b), in which the field winding is wired parallel to armature winding so that the voltage across both are same. The field winding has high resistance and more number of turns so that only a part of armature current passes through field winding and the rest passes through load. It is also called as constant flux machine.

Here  $I_a = I_{sh} + I_L$

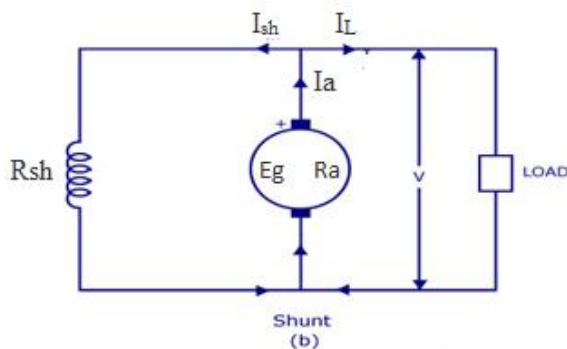

The output voltage is given by:  $-V = E_g - I_a \cdot R_a$  OR  $V = I_{sh} \cdot R_{sh}$

3. **Compound Generator** A compound generator is shown in figure below. It has two field windings namely  $R_{sh}$  and  $R_{se}$ . They are basically shunt winding ( $R_{sh}$ ) and series winding ( $R_{se}$ ). Compound generator is of two types – 1) Short shunt and 2) Long shunt



a) **Short shunt:-** Here the shunt field winding is wired parallel to armature and series field winding is connected in series to the load. It is shown in fig (a).

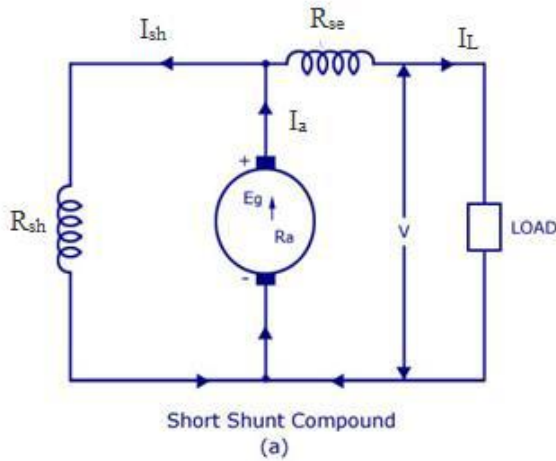

b) **Long shunt:-** Here the shunt field winding is parallel to both armature and series field winding ( $R_{se}$  is wired in series to the armature). It is shown in figure (b)

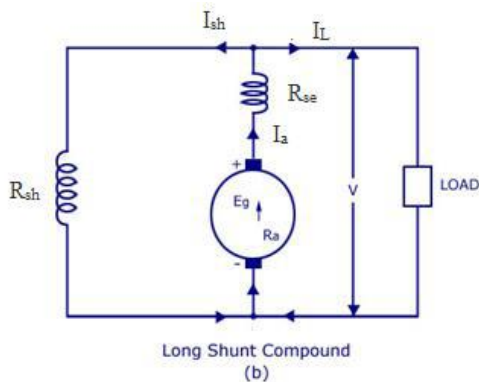

So you have got a basic idea about the types of DC generators! Now you may know that these generators are used only for special industrial purposes where there is huge demand for DC production. Otherwise, electrical energy is produced by AC generators and is transmitted from one place to other as AC itself. When a DC power is required, we usually convert AC to DC using rectifiers.

**Application:- Shunt Generators:**

- in electro plating ,for battery recharging , as exciters for AC generators.

**Series Generators :**



- As boosters , As lighting arc lamps

**Shunt Motor:**

- Blowers and fans, Centrifugal and reciprocating pumps, Lathe machines, Milling machines ,Drilling machines

**Series Motor:**

- Cranes, Hoists , Conveyors, Trolleys, Electric locomotives

**Cumulative compound Motor:**

- Rolling mills, Punches, Shears, Heavy planers, Elevators

## **Three Phase Induction Motor**

Three-phase induction motors are the most common machines used in industry.

- simple design, rugged, low-price, easy maintenance.
- wide range of power ratings: fractional horsepower to 10 MW
- run essentially as constant speed from zero to full load.
- not easy to have variable speed control

- ⊙ An induction motor has two main parts

1. **STATOR:** a stationary part of the motor is known as stator.

- It consist of a steel frame that supports a hollow, cylindrical core.
- The core, constructed from stacked laminations, having a number of slots, providing the space for the stator winding.

2. **ROTOR:** a revolving part of the motor is termed as rotor. It is composed of punched laminations, stacked to create a series of rotor slots, providing space for the rotor winding. there are two types of rotor windings used:

- a. Wound rotor: conventional 3-phase windings made of insulated wire, similar to the winding on the stator
- b. Squirrel cage rotor: An aluminum bus bars shorted together at the ends by two aluminum rings, forming a squirrel-cage shaped circuit.

- ⊙ Two basic design types depending on the rotor design
  - squirrel-cage
  - wound-rotor

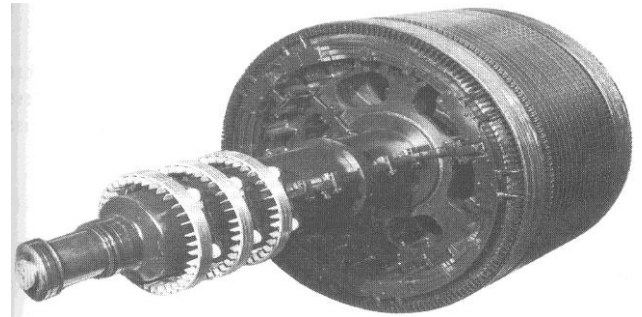
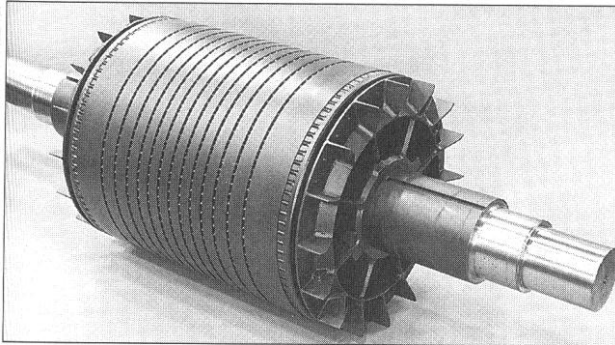

**Principle of operation:-**

When three phase ac supply is connected to 3 phase stator winding. A rotating magnetic field is produced in the air gap, rotating with a speed  $N_s = 120f/P$ . Where  $f$  is the supply frequency and  $P$  is the no. of poles and  $N_s$  is called the synchronous speed in *rpm*. This rotating magnetic field cuts the stationary rotor conductor and produces an induced voltage in the rotor windings

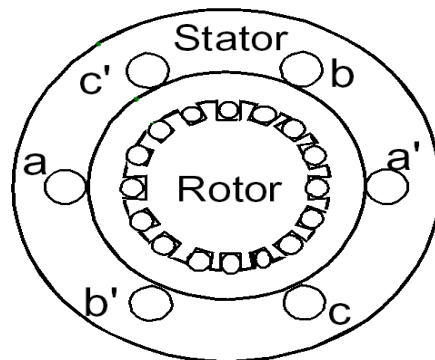

Due to the fact that the rotor windings are short circuited, so induced current flows in the rotor winding. According to Lenz's law this current tries to oppose the cause due to which it is produced, since the cause is relative motion between rotating magnetic field and stationary rotor conductor. So rotor starts rotating in same direction in which magnetic field rotate. The torque is produced as a result of the interaction of those two magnetic fields

Where  $\tau_{ind} = k B_R \times B_s$   
Where  $\tau_{ind}$  is the induced torque and  $B_R$  and  $B_s$  are the magnetic flux densities of the rotor and the stator respectively.

Q.Can the Induction motor runs at the synchronous speed, why?



No, Induction motor does not run at synchronous speed. If rotor runs at the synchronous speed, which is the same speed of the rotating magnetic field, then the rotor will appear stationary to the rotating magnetic field and the rotating magnetic field will not cut the rotor. So, no induced current will flow in the rotor and no rotor magnetic flux will be produced so no torque is generated and the rotor speed will fall below the synchronous speed. When the speed falls, the rotating magnetic field will cut the rotor windings and a torque is produced.

**Slip:-**

- ⦿ The Induction motor will always run at a speed lower than the synchronous speed
- ⦿ The difference between the motor speed and the synchronous speed is called the *Slip*. It is always expressed in percentage.

$$S = N_s - N_r$$

$$S = (N_s - N_r) / N_s ; \text{ Where } N_s = 120f/P$$

Where *S* = slip

*N<sub>s</sub>* = Synchronous speed or speed of the magnetic field

*N<sub>r</sub>* = speed of the motor.

The rotor current frequency or rotor frequency (*f<sub>r</sub>*) is given by

$$F_r = s.f \text{ Hz}$$

Notice that: if the rotor runs at synchronous speed *s* = 0 if the rotor is stationary *s* = 1

Note: the slip is a ratio and doesn't have units

**Torque-slip characteristics:-**

The torque slip curve for an induction motor gives us the information about the variation of torque with the slip.

$$T = \frac{k s R_2 E_{20}^2}{R_2^2 + (sX_{20})^2} \dots \dots \dots (1)$$

$$N_r = N_s(1 - s)$$



At starting,  $N_r = 0$  &  $s = 1$ . the starting torque will act on motor.

When  $N_r = N_s$  &  $s = 0$ , Torque act on motor will be zero.

Torque-slip characteristic curve can be divided into three regions

- ⊙ Low slip region ( $T \propto s$ )
- ⊙ Medium slip region
- ⊙ High slip region ( $T \propto 1/s$ )

The maximum torque is independent of the rotor resistance.

- ⊙ The motor will produce maximum torque, when slip  $s = R_2/X_{20}$ .

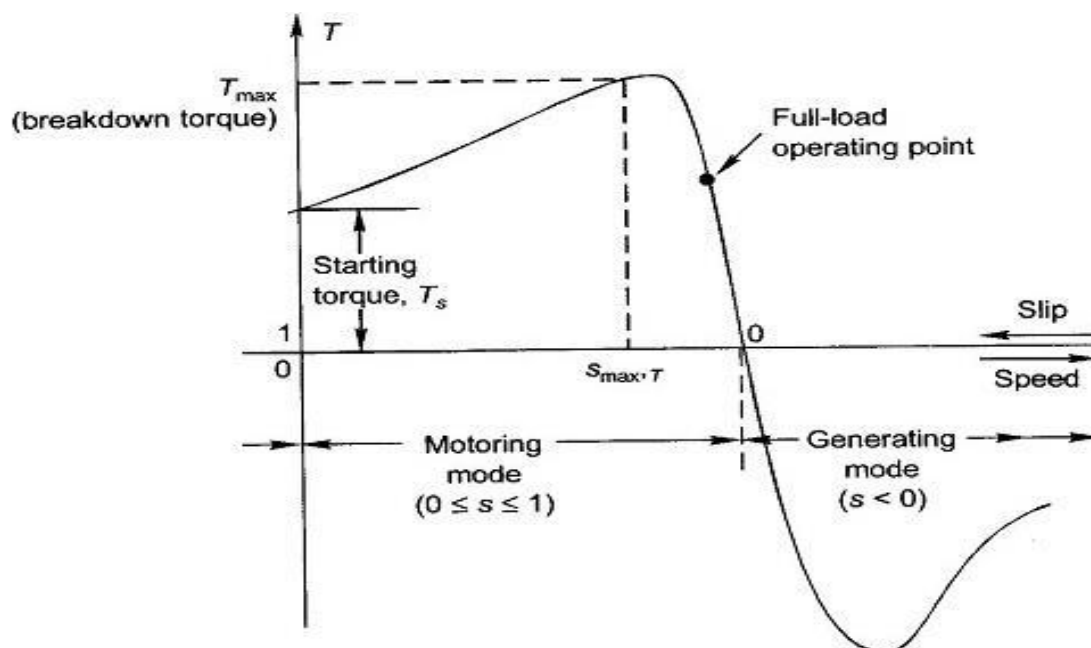

### ⊙ Motoring Mode

In this mode of operation, the motor always rotates below the synchronous speed. The slip varies from zero to one. It is zero at no load and one at standstill. From the curve it is seen that the torque is directly proportional to the slip i.e. more is the slip, more will be the torque produced and vice-versa.

### ⊙ Generating Mode

In this mode of operation induction motor runs above the synchronous speed. The torque and slip both are negative so the motor receives mechanical energy and delivers electrical energy.





## Single Phase Induction Motor

### Principle:-

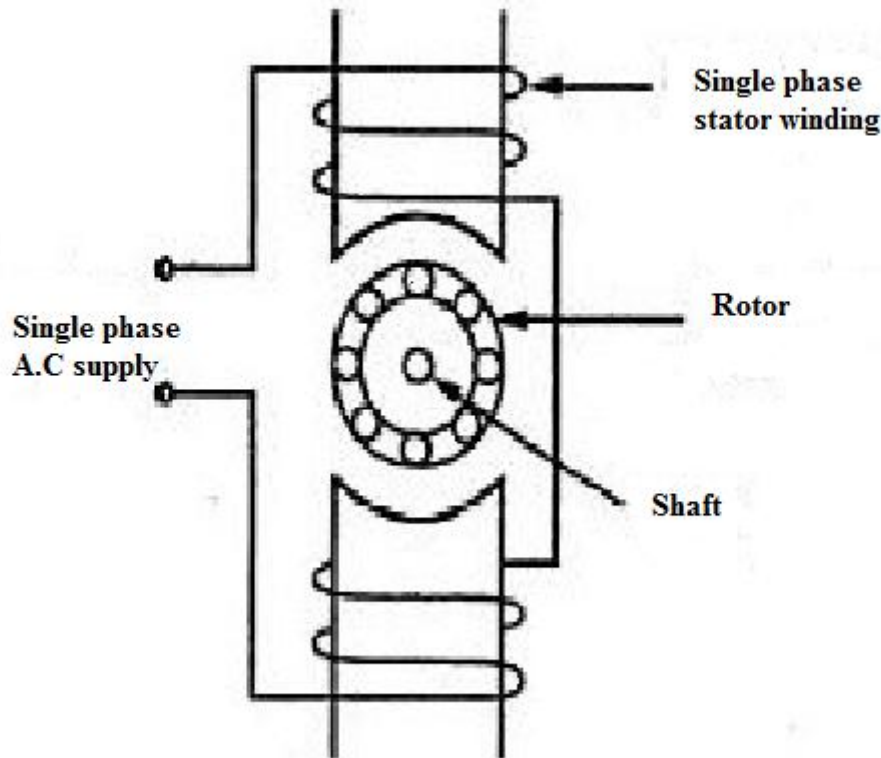

When we apply a single phase AC supply to the stator winding of single phase induction motor, the alternating current starts flowing through the stator or main winding. This alternating current produces an alternating flux called main flux. This main flux also links with the rotor conductors and hence cut the rotor conductors.

According to the Faraday's law of electromagnetic induction, emf gets induced in the rotor. As the rotor circuit is closed one so, the current starts flowing in the rotor. This current is called the rotor current. This rotor current produces its flux called rotor flux. Since this flux is produced due to the transformer action in opposite direction as of stator flux. Thus stator flux ( $\Phi_s$ ) always opposes rotor flux ( $\Phi_r$ ) in the same axis.

The torque angle between stator flux ( $\Phi_s$ ) and rotor flux ( $\Phi_r$ ) is  $180^\circ$ , hence no starting torque is developed.



$$T = \Phi_s \cdot \Phi_r \cdot \sin(180^\circ)$$

Thus Single Phase Induction Motor is not Self Starting.

### **Double revolving field theory:-**

According to double field revolving theory, we can resolve any alternating quantity into two components. Each component has a magnitude equal to the half of the maximum magnitude of the alternating quantity, and both these components rotate in the opposite direction to each other. For example – a flux,  $\phi$  can be resolved into two components

$$\frac{\phi_m}{2} \text{ and } -\frac{\phi_m}{2}$$

Each of these components rotates in the opposite direction i.e. if one  $\Phi_m / 2$  is rotating in a clockwise direction then the other  $\Phi_m / 2$  rotates in an anticlockwise direction.

When we apply a single phase AC supply to the stator winding of single phase induction motor, it produces its flux of magnitude,  $\Phi_m$ . According to the double field revolving theory, this alternating flux,  $\Phi_m$  is divided into two components of magnitude  $\Phi_m / 2$ . Each of these components will rotate in the opposite direction, with the synchronous speed,  $N_s$ .

Let us call these two components of flux as forwarding component of flux,  $\Phi_f$  and the backward component of flux,  $\Phi_b$ . The resultant of these two components of flux at any instant of time gives the value of instantaneous stator flux at that particular instant.

$$\text{i.e. } \phi_r = \frac{\phi_m}{2} + \frac{\phi_m}{2} \text{ or } \phi_r = \phi_f + \phi_b$$

Now at starting condition, both the forward and backward components of flux are exactly opposite to each other. Also, both of these components of flux are equal in magnitude. So, they cancel each other and hence the net torque experienced by the rotor at the starting condition is zero. So, the **single phase induction motors** are not self-starting motors.

### **Methods for Making Single Phase Induction as Self Starting Motor**

From the above topic, we can easily conclude that the single-phase induction motors are not self-starting because the produced stator flux is alternating in nature and at the starting, the two components of this flux cancel each other and hence there is no net torque. The solution to this problem is that if we make the stator flux rotating type, rather than alternating type, which rotates in one particular direction only. Then the induction motor will become self-starting.



Now for producing this rotating magnetic field, we require two alternating flux, having some phase difference angle between them. When these two fluxes interact with each other, they will produce a resultant flux. This resultant flux is rotating in nature and rotates in space in one particular direction only.

Once the motor starts running, we can remove the additional flux. The motor will continue to run under the influence of the main flux only. Depending upon the methods for making asynchronous motor as Self Starting Motor, there are mainly four **types of single phase induction motor** namely,

1. Split phase induction motor,
2. Capacitor start inductor motor,
3. Capacitor start capacitor run induction motor,
4. Shaded pole induction motor.
5. Permanent split capacitor motor or single value capacitor motor.

#### **Starting methods of single phase induction motor:-**

The single-phase induction motor is started by using some methods. Mechanical methods are not very practical methods that are why the motor is started temporarily by converting it into a two-phase motor. Single-phase induction motors are classified according to the auxiliary means used to start the motor. They are classified as follows:

1. Split-phase motor
2. Capacitor-start motor
3. Capacitor-start capacitor-run motor
4. Permanent-split capacitor (PSC) motor
5. Shaded-pole motor

#### **1. Split-phase induction motor:**

The split-phase induction motor is also known as a **resistance-start motor**. It consists of a single-cage rotor, and its stator has two windings, the main winding and a starting (also known as an auxiliary) winding. Both the windings are displaced by  $90^\circ$  in space like the windings in a two-phase induction motor. The main winding of the induction motor has very low resistance and high inductive reactance. Thus the current  $I_M$  in the main winding lags behind the supply voltage  $V$  by nearly  $90^\circ$ .

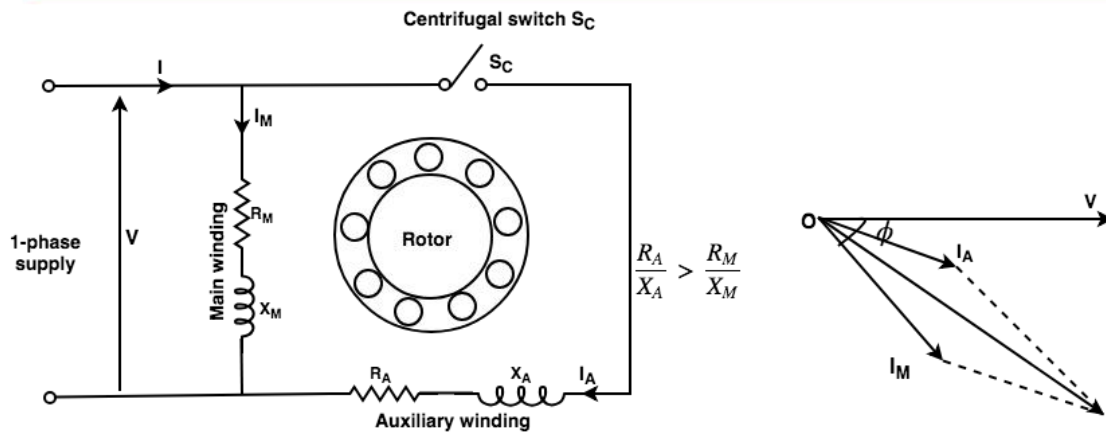

**Figure: Split-phase induction motor (a) Circuit diagram (b) Phasor diagram**

The starting winding has highly resistive and low inductive reactance. Thus  $I_A$  nearly in phase with supply voltage. Thus there is time difference between the currents in the two windings. This phase difference is enough for producing rotating magnetic field. As motor reaches 70-80 per cent of synchronous speed, starting winding disconnects from main winding using centrifugal switch.

### Applications:

Split-phase motors are most suitable for easily started loads where the frequency of starting is limited, and these are very cheap.

1. These motors are used in washing machines.
2. These are used in Air conditioning fans.
3. Used in food mixers, grinders, floor polishers, blowers, centrifugal pumps,
4. These are used in small drills, lathes, office machinery, etc.
5. Sometimes they are also used for drives requiring more than 1kW.

### Capacitor motors:

Capacitor motors are the motors that have a capacitor in the auxiliary winding circuit to produce a greater phase difference between the current in the main and auxiliary windings. There are three types of capacitor motors.

### 2. Capacitor-start motor:



In this motor capacitor is connected in series with starting winding. The capacitor-start motor develops a much higher starting torque, i.e. 3.0 to 4.5 times the full-load torque. To obtain a high starting torque, the value of the starting capacitor must be large, and the resistance of starting winding must be low. Because of the high VAR rating of the capacitor required, electrolytic capacitors of the order of 250  $\mu\text{F}$  are used. The capacitor  $C_s$  is short-time rated. As motor reaches 70-80 % of rated speed, starting winding with capacitor automatically disconnected. These motors are more costly than split-phase motors because of the additional cost of the capacitor.

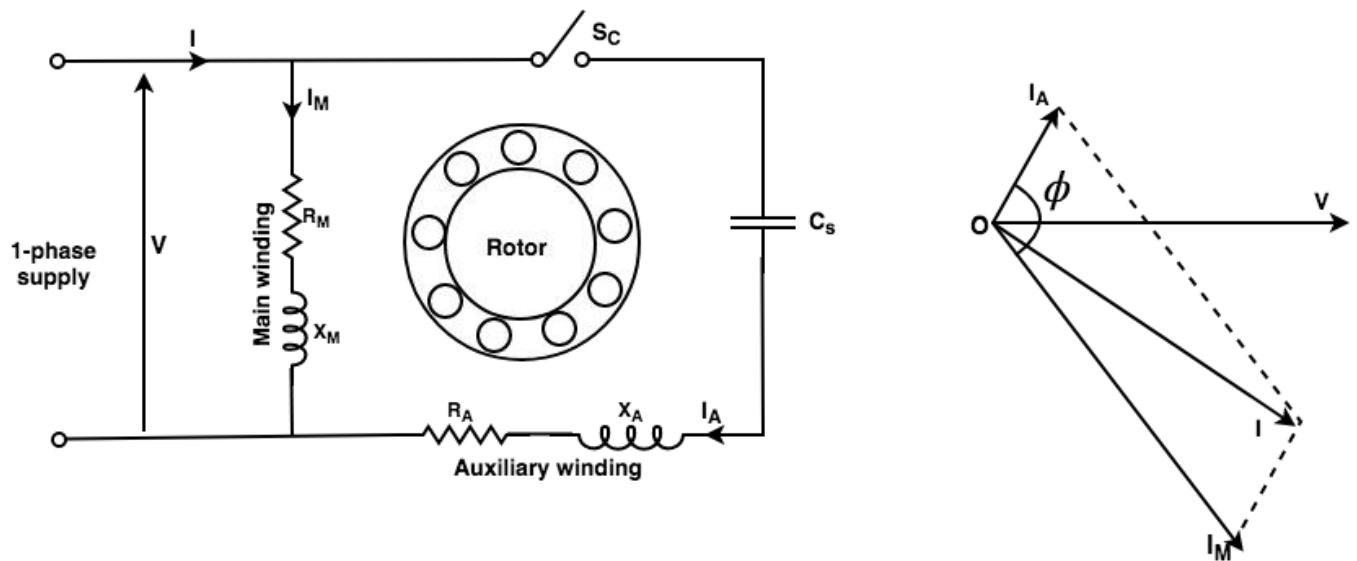

**Figure: Capacitor start motor (a) circuit diagram (b) Phasor diagram**

### Applications:

1. These motors are used for heavy loads where frequent start required.
2. These motors are used for pumps and compressors, so these are used as a compressor in the refrigerator and air conditioner.
3. They are also used for conveyors and some machine tools.

### 3. Capacitor Start Capacitor Run Motor:-

This motor has a cage rotor, and its stator has two windings namely the main winding and the auxiliary winding. The two windings are displaced 90 in space. The motor use two capacitors  $C_s$  and  $C_R$ . Capacitor  $C_s$  is called starting capacitor and it is high value capacitor. It disconnects after reaching rated speed.  $C_R$  is called running capacitor of low value and connected throughout the operation. In the initial stage, the two capacitors are connected in parallel.

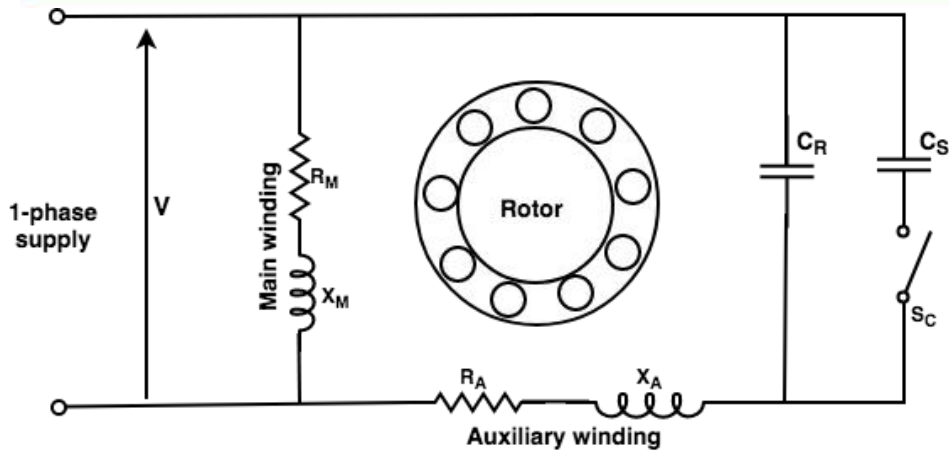

**Applications:**

1. Two value capacitor motors are used for loads of higher inertia that requires frequent start.
2. These are used in pumping equipment.
3. These are used in refrigeration, air compressors, etc.

**4. Permanent-split Capacitor (PSC) motor:**

These motors have a cage rotor, and its rotor consists of two windings namely, the main winding and the auxiliary winding. The single-phase induction motor has only one capacitor C which is connected in series with the starting winding. The capacitor C is permanently connected in series with the starting winding. The capacitor C is permanently connected in the circuit at starting and running conditions.

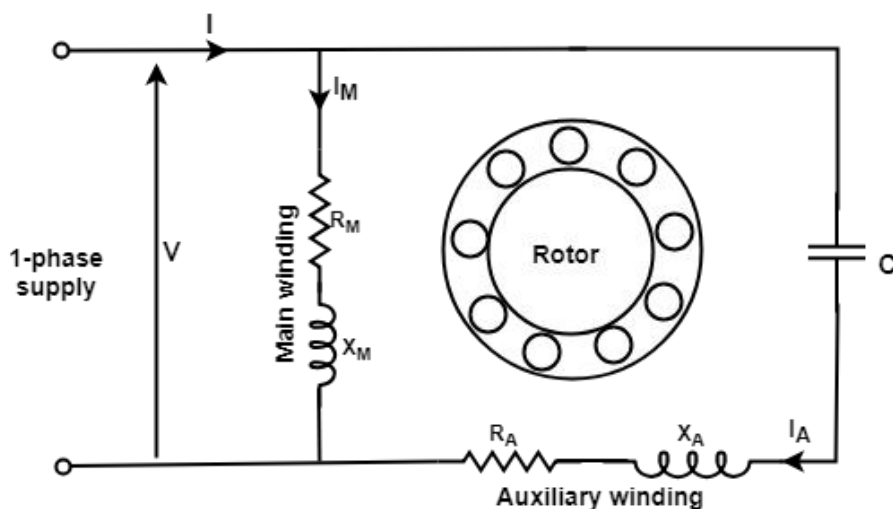

Figure: Permanent-split capacitor motor



**Advantages:** A single-value capacitor motor has the following advantages:

1. In this type of motor, no centrifugal switch is required.
2. This motor has higher efficiency.
3. It has higher power-factor because of a permanently-connected capacitor.
4. It has higher pull-out torque.

**Limitations of permanent-split capacitor motor:**

1. Electrolytic capacitors cannot be used for continuous running. Therefore, paper-spaced oil-filled type capacitors are to be used. Paper capacitors of the same rating are larger in size and more costly.
2. A single-value capacitor has a low starting torque usually less than full-load torque.

**Applications:**

1. These motors are used for fans and blowers in heaters.
2. It is used in air conditioners.
3. It is used to drive refrigerator compressors.
4. It is also used to operate office machinery.

### **5. Shaded pole motor:**

A shaded-pole motor is a simple type of self-starting single-phase induction motor. It consists of a stator and a cage-type rotor. The stator is made up of salient poles. Each pole is slotted on the side, and a copper ring is fitted on the smaller part. This part is called the shaded pole. The ring is usually a single-turn coil and is known as shading coil.

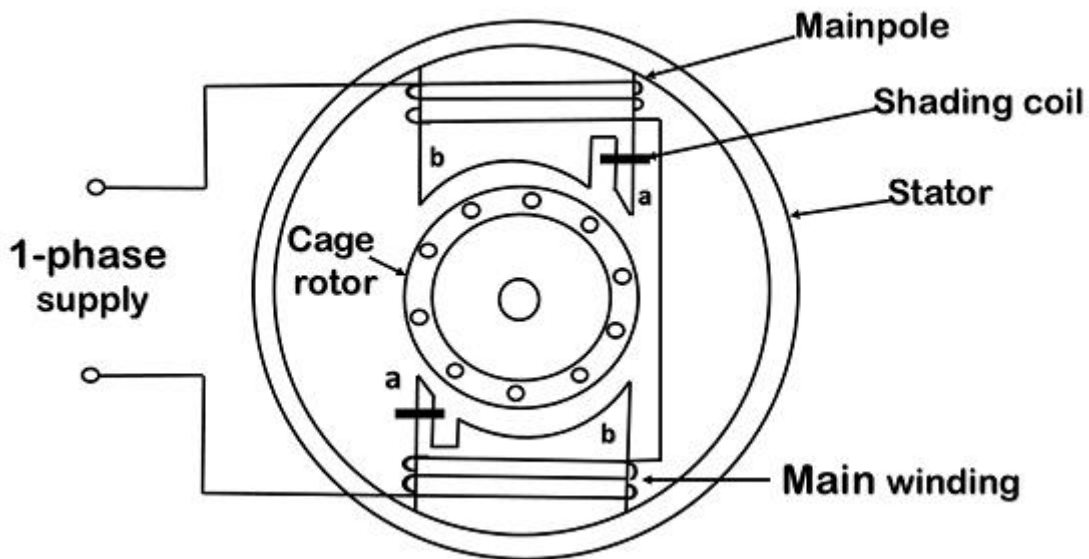

**Figure: Shaded-pole motor with two stator poles.**

**Applications:**

1. Shaded-pole motors are used to drive devices which require low starting torque.
2. These motors are very suitable for small devices like relays, fans of all kinds, etc. because of their low initial cost and easy starting.
3. The most common application of these motors is in table fans, exhaust fans, hair dryers, fans for refrigeration and air-conditioning equipment, electronic equipment, cooling fans, etc.





## Synchronous machine

Synchronous motor is doubly excited machine. The stator winding is excited with 3 phase A.C supply and rotor winding with D.C supply respectively. When a three-phase supply is given to the stator of a three-phase wound synchronous motor, a rotating field is set up in the air gap which rotates at synchronous speed ( $N_s = 120f/p$ ). This is represented by the imaginary stator poles.

The synchronous motor works on the principle of magnetic locking. The operating principle can be explained with the help of a 2-Pole synchronous machine with the following steps.

Let us consider a two-pole synchronous motor as shown in Figure. The three-phase supply is provided to the stator which induces two poles i.e North pole and the South pole on Stator. Since the supply in the stator is alternating in nature, therefore, its polarity changes in every half cycle, thus the poles of stator also changes after every half cycle.

The synchronous motor rotor is energized by the DC current. The field current (D.C Current) of the motor produces a steady-state magnetic field. Since the polarity of D.C current is fixed therefore the poles of rotor don't vary.

Therefore, there are two magnetic fields present in the machine. **Stator poles changes in every half-cycle whereas rotor poles remain the same.**

**Step 1.** When a three-phase supply is given to the stator winding, a rotating magnetic field is produced in the stator.

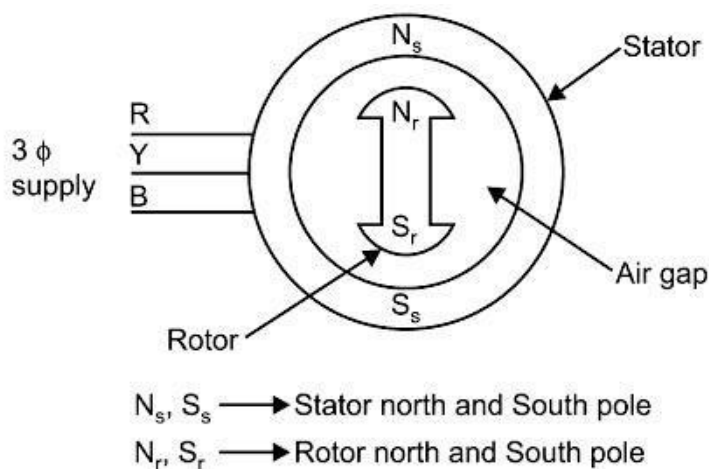



**Step 2.**

- Due to the Rotating Magnetic field, let the stator poles i.e North poles ( $N_s$ ) and South Poles ( $S_s$ ) rotate with synchronous speed.
- At a particular time stator pole,  $N_s$  coincides with the rotor poles  $N_r$  and  $S_s$  coincides with  $S_r$  i.e like poles of the stator and rotor coincide with each other.
- As we know, like poles experience a repulsive force. So rotor poles experience a repulsive force  $F_r$ . Let us assume that the rotor tends to rotate in the anti-clockwise direction as shown in Fig. (i).

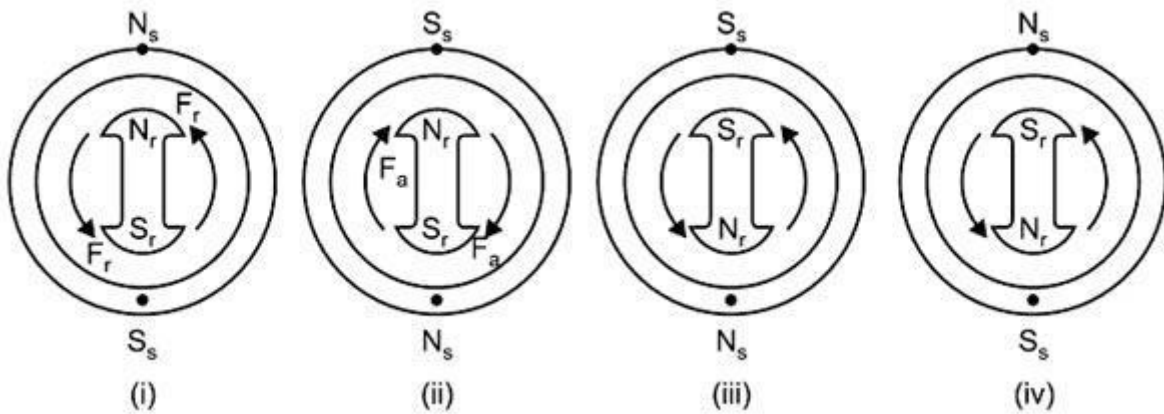

**Step-3.**

- After half cycle, the polarity of the stator pole is reversed, whereas the rotor poles cannot change their polarity as shown in Fig. (ii).
- Now unlike poles of rotor and Stator coincide with each other and rotor experiences the attractive force  $f_a$  and the rotor tends to rotate in the clockwise direction.
- In brief, we can say, with the rotation of stator poles the rotor tends to drive in the clockwise and anti-clockwise direction in every half cycle.
- Hence, to and fro motion is excited on the rotor and as a result, the rotor does not rotate. As a result, the average torque on the rotor is zero. **Hence the 3-phase synchronous motor is not a self-starting motor.**

**Application:-**

1. For constant speed application.
2. For improving power factor of substation.



## MODULE 5: Electrical Installations

**Contents:** Components of LT Switchgear: Switch Fuse Unit (SFU), MCB, ELCB, MCCB, Types of Wires and Cables, Importance of earthing. Types of Batteries, Important characteristics for Batteries. Elementary calculations for energy consumption and savings, battery backup.

### Components of LT Switchgear: Switch Fuse Unit (SFU), MCB, ELCB, MCCB:

**Switchgear:** The apparatus used for switching, controlling and protecting the electrical circuits and equipment is known as switchgear.

The term 'switchgear' is a generic term encompassing a wide range of products like circuit breakers, switches, switch fuse units, off-load isolators, HRC fuses, contactors, earth leakage circuit breaker, etc...

#### Classification of Switchgear:

Switchgear can be classified on the basis of voltage level into the following:

1. Low voltage (LV) Switchgear: upto 1KV
2. Medium voltage (MV) Switchgear: 3 KV to 33 KV
3. High voltage (HV) Switchgear: Above 33 KV

#### Components of LT Switchgear:

The term LT Switchgear includes low voltage Circuit Breakers, Switches, off load electrical isolators, HRC fuses, Earth Leakage Circuit Breaker, Miniature Circuit Breakers (MCB) and Molded Case Circuit Breakers (MCCB) etc i.e. all the accessories required to protect the LV system.

The most common use of LV switchgear is in LV distribution board.

#### FUSE:

Fuse is perhaps the simplest and cheapest device used for interrupting an electrical circuit under short circuit, or excessive overload, current magnitudes. The action of a fuse is based upon the heating effect of the electric circuit. The fuse has inverse time-current characteristics as shown in the next slide. The part which actually melts and opens the circuit is known as the fuse element.

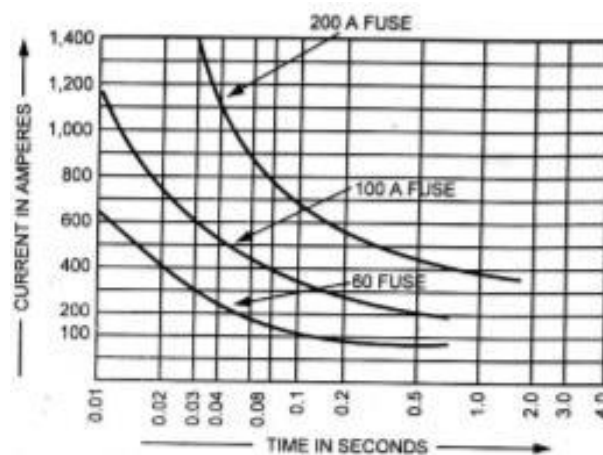

*Time-Current Characteristics*

Fuses have following advantages and disadvantages:

#### Advantages:



1. It is cheapest form of protection available.
2. It needs no maintenance.
3. Its operation is inherently completely automatic unlike a circuit breaker which requires an elaborate equipment for automatic action.
4. It interrupts enormous short circuit currents without noise, flame, gas or smoke.

**Disadvantages:**

1. Considerable time is lost in rewiring or replacing a fuse after operation.
2. On heavy short circuits, discrimination between fuses in series cannot be obtained unless there is considerable differences in the relative sizes of the fuse concerned.
3. The current-time characteristics of a fuse cannot always be correlated with that of the protected device.

**FUSE:** *Fuse is provided only in phase or live pole, never on neutral pole.*

**FUSE UNITS:** The various types of fuse units, most commonly available are:

1. Round type fuse unit.
  2. Kit-kat type fuse unit.
  3. Cartridge type fuse unit.
  4. HRC (High Rupturing Capacity) fuse units and
  5. Semiconductor fuse units.
- 1. Round type fuse unit:** This type of fuse unit consists of a porcelain or bakelite box and two separated wire terminals for holding the fuse wire between them. This type of fuse is not common use on account of its following disadvantages:
- One of the terminals remain always energized and, therefore, for replacement of fuse either the worker will have to touch the live mains or open the main switch.
  - Appreciable arcing takes place at the instant of blowing off fuse and thus damage the terminals. After two or three arcing the fuse unit becomes unusable.
- 2. Rewirable or Kit-kat Type Fuses:** The most commonly used fuse in “house wiring” and small current circuits is the semi-enclosed or rewirable fuse (also sometimes known as kit-kat type fuse). It consists of a porcelain base carrying the fixed contacts to which the incoming and outgoing live or phase wires are connected and a porcelain fuse carrier holding the fuse element, consisting of one or more strands of fuse wire, stretched between its terminals.

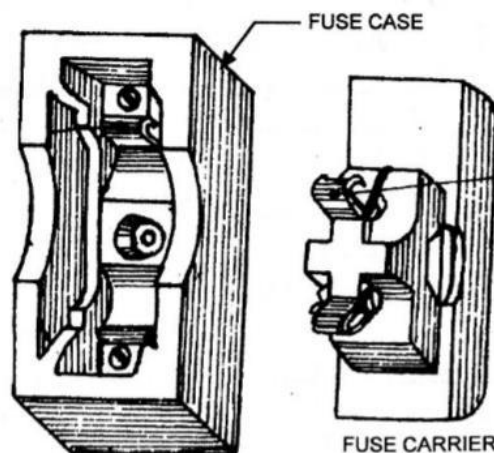

The fuse wire may be of lead, tinned copper, aluminium or an alloy of tin-lead. The actual fusing current will be about twice the rated current.



The specifications for rewirable fuses are covered by IS: 2086-1963. Standard ratings are 6, 16, 32, 63 and 100A. A fuse wire of any rating not exceeding the rating of the fuse may be used in it i.e. a 80A fuse wire can be used in a 100A fuse, but not in the 63A fuse.

**Disadvantages of Rewirable or Kit-kat Type Fuses:**

- Unreliable operation.
- Lack of discrimination.
- Small time lag.
- Low rupturing capacity.
- No current limiting feature.
- Slow speed of operation.

**3. Cartridge Type Fuses:** This is a totally enclosed type fuse unit. It essentially consists of an insulating container of bulb or tube shape and sealed at its ends with metallic cap known as cartridge enclosing the fuse element and filled with powder or granular material known as filler.

There are various types of materials used as filler like sand, calcium carbonate, quartz etc. This type of fuse is available upto 660V and the current rating upto 800 A.

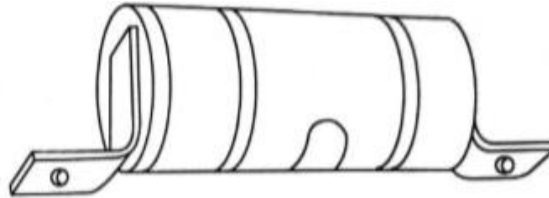

**4. High Rupturing Capacity (HRC) Fuses:** With a very heavy generating capacities of the modern power stations, extremely heavy currents would flow into the fault and fuse clearing the fault would be required to withstand extremely high stresses in this process. HRC fuses developed and designed after intensive research for use in medium and high voltage installations. Their rupturing capacity is as high as 500MVA up to 66 KV and above. There are basically two types of HRC fuses are used.

1. Cartridge Type HRC Fuse.
2. Tetra Chloride Type HRC Fuse.

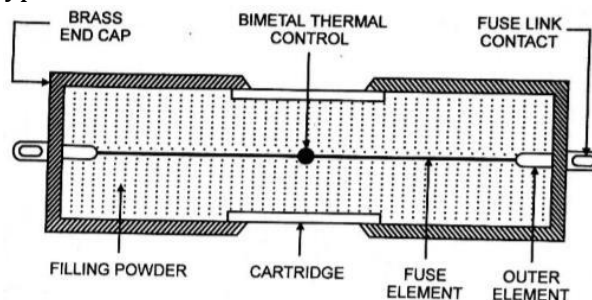

**5. Semiconductor Fuses:** These are very fast acting fuses for protection of thyristor and other electronic circuits.

**Switch Fuse Unit (SFU):**

Switch fuse is a combined unit and is known as an iron clad switch, being made of iron. It may be double pole for controlling single phase two-wire circuits or triple pole for controlling three-phase, 3-wire circuits or triple pole with neutral link for controlling 3-phase, 4-wire circuits. The respective switches are known as double pole iron clad (DPIC), triple pole iron clad (TPIC), and triple pole with neutral link iron clad (TPNIC) switches.

**1. For Two-wire DC Circuits or Single Phase AC Circuits:** 240V, 16A, DPIC switch fuse



2. **For Three-Wire DC Circuits:** 500V, 32A (63/100/150 or higher amperes), IS approved TPIC switch fuse.

3. **For Three-Phase Balanced Load Circuits:** 415V, 32A (63/100/150 or higher amperes), IS approved TPIC switch fuse.

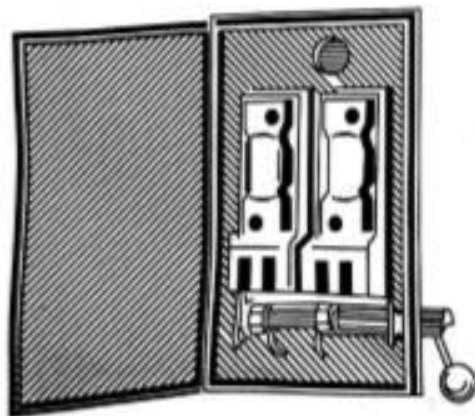
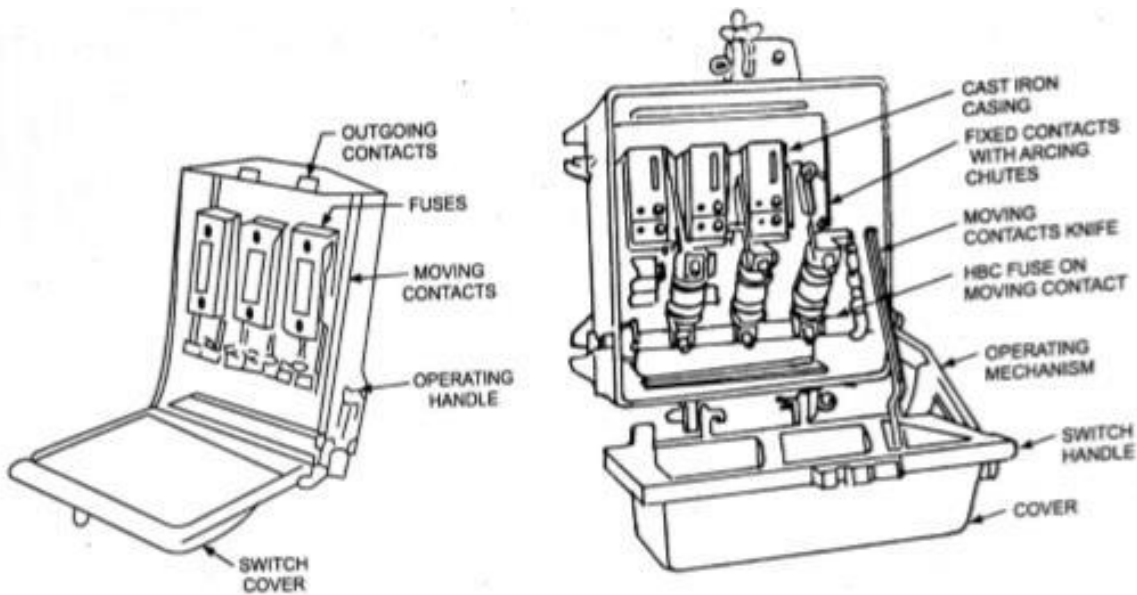
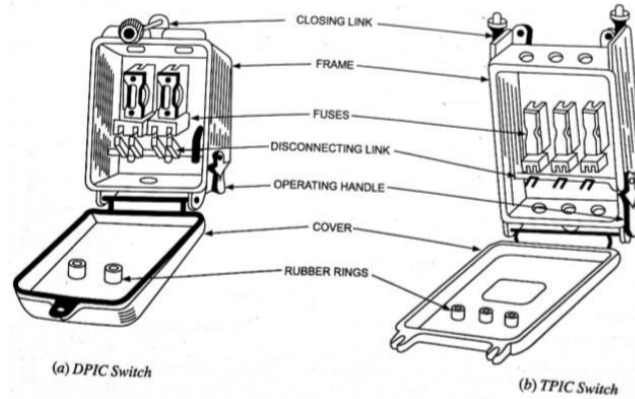

(a) Double Pole Iron Clad Switch

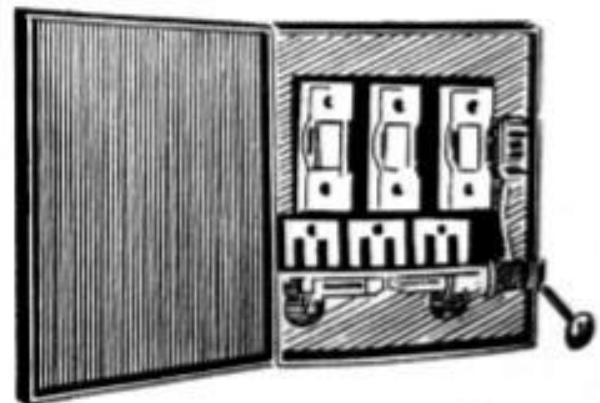

(b) Triple Pole, Iron Clad Switch

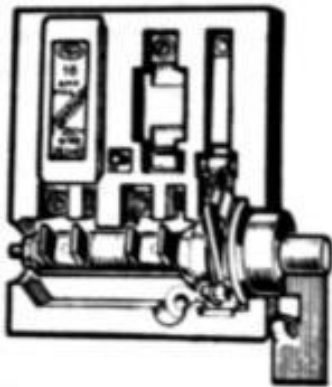

*(c) 16-Amp. All insulated Main Switch*



*(d) All insulated Switch With Moulded Cover and Base For Circuits Up to 16 Amperes Capacity*

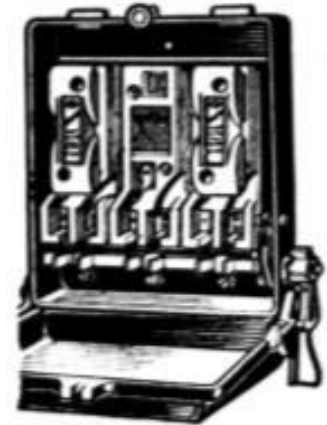

*(e) Three-Phase Iron Clad Main Switch For Power Use*

### **Miniature Circuit Breaker (MCB):**

A device which provides definite protection to the wiring installations and sophisticated equipment against over-currents and short-circuit faults. Thermal operation (overload protection) is achieved with a bimetallic strip, which deflects when heated by any over-currents flowing through it. In doing so, releases the latch mechanism and causes the contacts to open. Inverse-time current characteristics result. i.e. greater the overload or excessive current, shorter the time required to operate the MCB. On occurrence of short circuit, the rising current energizes the solenoid, operating the plunger to strike the trip lever causing immediate release of the latch mechanism. Rapidity of the magnetic solenoid operation causes instantaneous opening of contacts.

MCBs are available with different current ratings of 0.5, 1.2, 2.5, 3, 4, 5, 6, 7.5, 10, 16, 20, 25, 32, 35, 40, 63, 100, 125, 160 A and voltage rating of 240/415 V AC and up to 220 V DC. Operating time is very short (less than 5 ms).

They are suitable for the protection of important and sophisticated equipment, such as air-conditioners, refrigerators, computers etc.

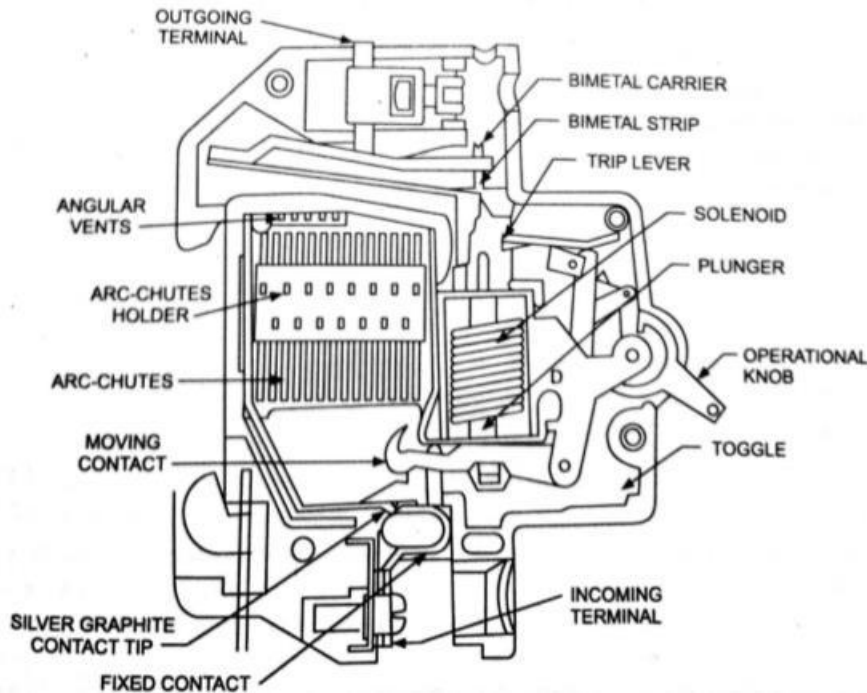

### **Earth Leakage Circuit Breaker (ELCB):**

It is a device that provides protection against earth leakage. These are of two types.

1. **Current operated earth leakage circuit breaker:**
2. **Voltage operated earth leakage circuit breaker.**

**1. Current operated earth leakage circuit breaker:** It is used when the product of the operating current in amperes and the earth-loop impedance in ohms does not exceed 40. such circuit breakers is used where consumer's earthing terminal is connected to a suitable earth electrode. A current-operated earth leakage circuit breaker is applied to a 3-phase, 3-wire circuit.

In normal condition when there is no earth leakage, the algebraic sum of the currents in the three coils of the current transformers is zero, and no current flows through the trip coil. In case of any earth leakage, the currents are unbalanced and the trip coil is energized and thus the circuit breaker is tripped.

**2. Voltage operated earth leakage circuit breaker:** It is suitable for use when the earth-loop impedance exceeds the values applicable to fuses or excess-current circuit breaker or to current operated earth leakage circuit breaker. When the voltage between the earth continuity conductor (ECC) and earth electrode rises to sufficient value, the trip coil will carry the required current to trip the circuit breaker. With such a circuit breaker the earthing lead between the trip coil and the earth electrode must be insulated; in addition, the earth electrode must be placed outside the resistance area of any other parallel earths which may exist.

In both the above types of ELCB the tripping operation may be tested by means of a finger-operated test button which passes a predetermined current from the line wire through a high resistance to trip the coil and thus to earth. This test operation should be performed regularly.



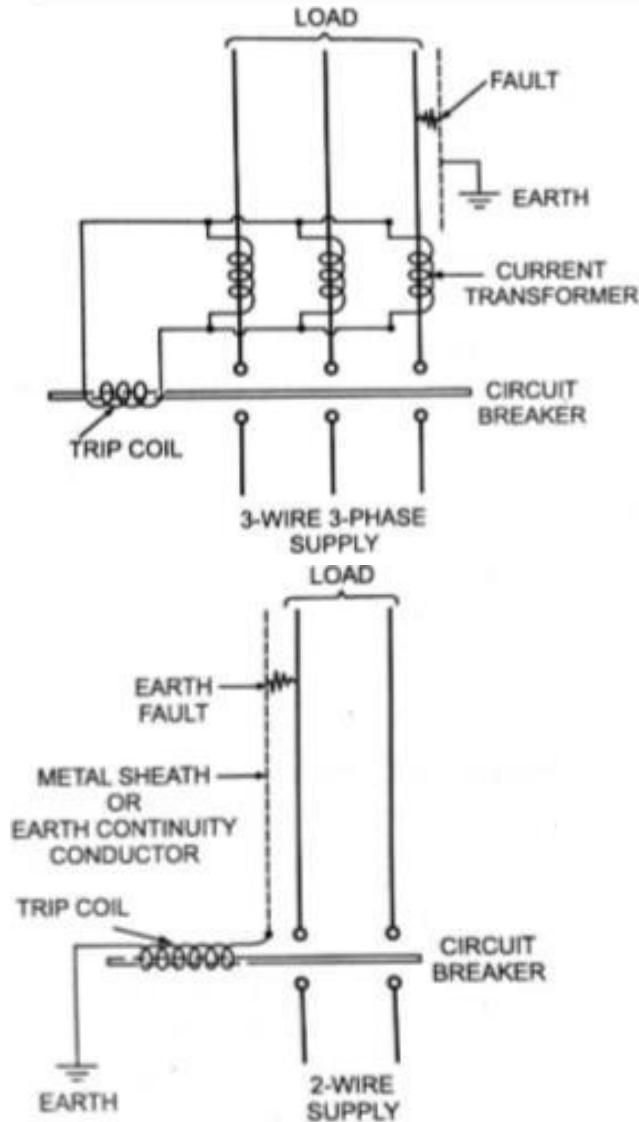

Fig: Current Operated ELCB

Fig: Voltage Operated ELCB

### **Molded Case Circuit Breaker (MCCB) :**

It is a type of electrical protection device that can be used for a wide range of voltages, and frequencies of both 50 Hz and 60 Hz, the main distinctions between molded case and miniature circuit breaker are that MCCB can have current rating up to 2500 amperes, and its trip setting are normally adjustable. MCCBs are much larger than MCBs. An MCCB has three main functions:

- **Protection against overload.**
- **Protection against electrical faults.**
- **Switching a circuit ON and OFF.** This is a less common function of circuit breakers, but they can be used for that purpose if there is not an adequate manual switch.

The wide range of current ratings available from molded-case circuit breakers allows them to be used in a wide variety of applications. MCCBs are available with current ratings that range from low values such as 15 amperes, to industrial ratings such as 2500 amperes. This allows them to be used in both low power and high power applications.

**Operating Mechanism:** At its core, the protection mechanism employed by MCCBs is based on the same physical principles used by all types of thermal-magnetic circuit breakers.



- Overload protection is accomplished by means of a thermal mechanism. MCCBs have a bimetallic contact that expands and contracts in response to changes in temperature. Under normal operating conditions, the contact allows electric current through the MCCB. However, as soon as the current exceeds the adjusted trip value, the contact will start to heat and expand until the circuit is interrupted.
- The thermal protection against overload is designed with a time delay to allow short duration overcurrent, which is a normal part of operation for many devices. However any over current conditions, that lasts more than what is normally expected represent an overload, and the MCCB is tripped to protect the equipment and personnel. On the other hand, fault protection is accomplished with electromagnetic induction, and the response is instant. Fault currents should be interrupted immediately, no matter if their duration is short or long. Whenever a fault occurs, the extremely high current induces a magnetic field in a solenoid coil located inside the breaker-this magnetic induction trips a contact and current is interrupted. As a complement to the magnetic protection mechanism, MCCBs have internal arc dissipation measures to facilitate interruption.

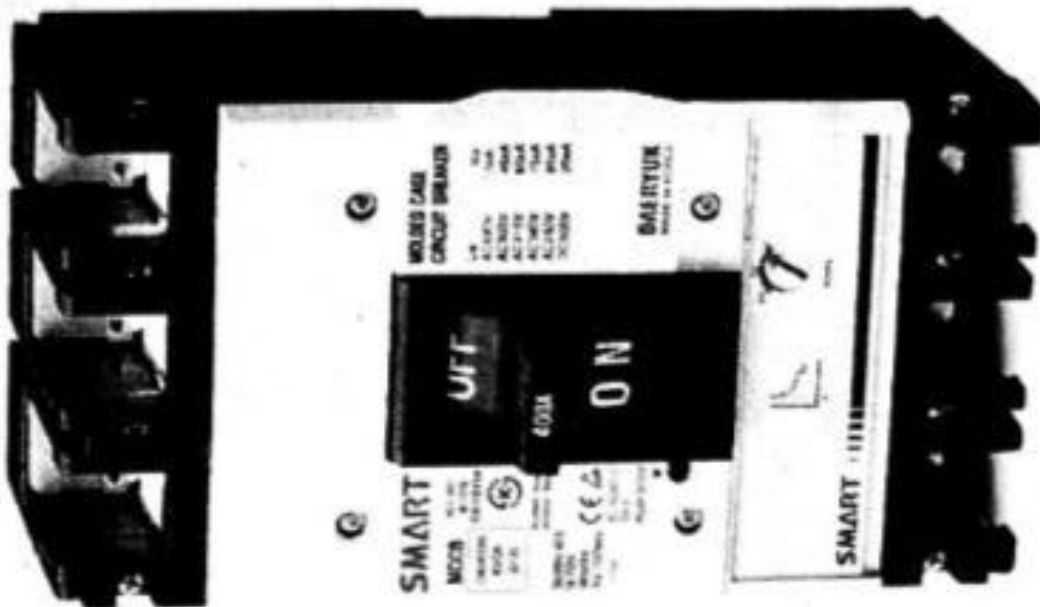

## Types of Wires and Cables:

For internal wiring of any building, wires and cables may be categorized into following groups:



1. Conductor Used: According to conductor material used in the cables, these may be divided into two classes known as copper conductor cables and aluminium conductor cables.
  2. Number of Cores Used: It may be divided into different classes known as: single core cables, twin core cables, three core cables, two core with ECC (Earth Continuity Conductor) cables etc.
  3. Voltage Grading: According to voltage grading the cables may be divided into two classes (i) 250/440 Volt cables and (ii) 650/1100 volt cables
  4. Types of Insulation Used: According to type of insulation the cables are of following types:
    - Vulcanized Indian Rubber (VIR) insulated cables
    - Tough Rubber Sheathed (TRS) or Cab Tyre Sheathed (CTS) cables.
    - Lead Sheathed Cables.
    - Polyvinyl Chloride (PVC) Cables.
    - Weatherproof cables.
    - Flexible cords and cables.
    - XLPE cables.
    - Multi-strand cables.
- **Vulcanized Indian Rubber (VIR) insulated cables:** VIR cables are available in 240/415 volts as well as in 650/1100 volt grades. VIR cables consists of either Tinned copper conductor Covered with a layer of VIR insulation. Over the rubber Insulation cotton tape sheathed Covering is provided with Moisture resistant compound bitumen wax or some other insulating material for making the cables moisture proof.

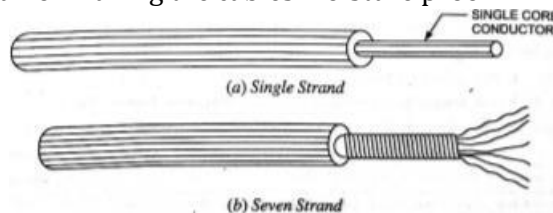
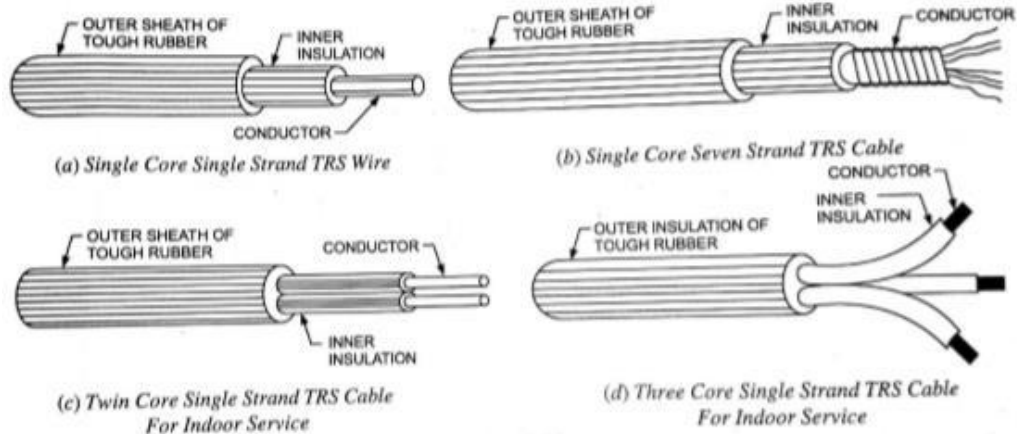
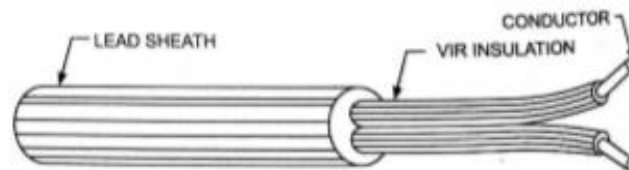

Figure: Single Core VIR Cables

- **Tough Rubber Sheathed (TRS) or Cab Tyre Sheathed (CTS) cables:** These cables are available in 250/440 volt and 650/1100 volt grades and used in CTS (or TRS) wiring. TRS cable is nothing but a VIR conductor with an outer protective covering of tough rubber, which provides additional insulation and protection against wear and tear. These cables are waterproof, hence can be used in wet conditions. These cables are available as single core, circular twin core, circular three core, flat three core, twin or three core with an earth continuity conductor. The core are insulated from each other and covered with a common sheathing.
- These cables are cheaper in cost and lighter in weight than lead alloy sheathed cables and have the alloy sheathed cables and have the properties similar to those of lead sheathed cables and thus provide cheaper substitute to lead sheathed cables.



- **Lead Sheathed Cables:** These cables are available in 240/415 volt grade. The lead sheathed cable is a vulcanized rubber insulated conductor covered with a continuous sheath of lead. The lead sheath provides very good protection against the absorption of moisture and sufficient protection against mechanical injury and so can be used without casing or conduit system. It is available as a single core, flat twin core, flat three core and flat twin or three core with an earth continuity conductor. Two-core lead sheathed cable is shown in the given figure.



- **Polyvinyl Chloride Insulated Cables:** These cables are available in 250/440 volt and 650/1100 volt grades and are used in casing-capping, batten and conduit wiring system. In this type of cable, conductor is insulated with PVC insulation. Since PVC is harder than rubber, PVC cable does not require cotton taping and braiding over it for mechanical and moisture protection. PVC insulation is preferred over VIR insulation because of the following reasons:
- PVC insulation has better insulating qualities.
  - PVC insulation provides better flexibility.
  - PVC insulation has no chemical effect on metal of the wire.
  - Thin layer of PVC insulation will provide the desired insulation level.
  - PVC coated wire gives smaller diameter of cable and, therefore, more no. of wires can be accommodated in the conduit of a given size in comparison to VIR or CTS wires.
- PVC cables are most widely used for internal wiring these days. Though the insulation resistance of PVC is lower than that of VIR but its effect is negligible for low and medium voltages, below 600 V.
- **Weather Proof Cables:** These cables are used for outdoor wiring and for power supply or industrial supply. These cables are either PVC insulated or vulcanized rubber insulated conductors being suitably taped braided and then compounded with weather resisting material. These cables are available in 240/415 volt and 650/1100 volt grades. These cables are not affected by heat or sun or rain. Weather proof cables are shown in the given figure:

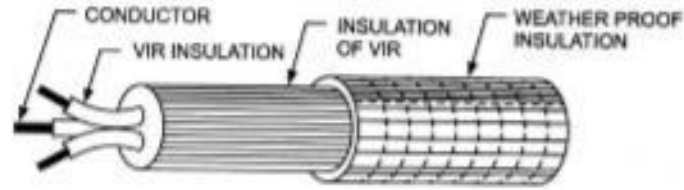

- **Flexible Cords and Cables:** The flexible cords consist of wires silk/cotton/plastic covered. Plastic cover is popular as it is available in different pleasing colours. Flexible cords have tinned copper conductors. Flexibility and strength is obtained by using conductors having large no. of strands. These wires or cables are used as connecting wires for such purposes as from ceiling rose to lamp holder, socket outlet to portable apparatus such as radios, fans, lamps, heaters etc. These must not be used for fixed wiring.

The flexible cords used for household appliances are available in various sizes and in various thickness of coating as very thin/thin/medium/thick/very thick/extra thick etc.

- **XLPE Cables:** PVC and XLPE cables are built of insulation made of polymers. Polymers are substances consisting of long macromolecules built up of small molecules or group of molecules as repeated units. These are divided into homopolymers and copolymers. Homopolymers are built by reactions of identical monomers. Copolymers are built up of at least two different kinds of monomers.

The mechanical properties of the polymers e.g. tensile strength, elongation elasticity, and resistance against cold depend upon chemical structure. Their resistance against external chemical influences, acids, bases or oils together with their electrical and thermal characteristics are the decisive factors for the usefulness of cables insulated and sheathed with these materials.

- **Multi-Stranded Cables:** Multi-stranded cables have got the following advantages with respect to the single solid conductor and hence preferred.
  - The multi-stranded cables are more flexible and durable and, therefore, can be handled conveniently.
  - The surface area of multi-strand cable is more as compared to the surface area of equivalent single solid conductor, so heat radiating capacity being proportional to the surface area is more.
  - Skin effect is better as the conductors are tubular, especially in the case of high frequency.

### Importance of earthing:

An electrical equipment or appliance is said to be earthed, if its outer frame and its other parts not carrying any current are connected to the earth so as to attain as nearly zero potential as possible. In practice, all equipments and machinery, as well as electric poles, towers, neutral wires, etc, are earthed. The purpose of earthing is to ensure that all parts of the system other than live parts are maintained at the earth potential at all times.

### Objective of Earthing:

1. The main objective of earthing is to provide safety of operation.
2. Another objective of the earthing, though not widely used nowadays, is to save conducting material.



3. It also helps in protecting high-rise buildings from atmospheric lightening. A fork metal rod or thick wire, called the lightening conductor, sticks out from the top of the building, chimney, tower, etc. its other end buried deep into the ground. Whenever lightening occurs, the electricity passes directly from the top of lightening conductor to the earth, thereby protecting the building from any damage.

**Methods of Earthing:** Earthing should be done in a way so that on a short circuit, the earth loop impedance is low enough to pass 3 times the current if fuses are used, and 1.5 times the current if MCBs are used. The metal work should be solidly earthed without using any switch or fuse in the circuit.

For effective earthing, the resistance offered by the earth electrode along with the soil in which electrode is embedded should be quite low.

Galvanised Iron (GI) or copper is used to make an earth electrode.

There are different types of earthing methods are used:

1. Strip or Wire Earthing.
2. Rod Earthing.
3. Pipe Earthing.
4. Plate Earthing.

Pipe and Plate Earthings are commonly used.

1. **Strip or Wire Earthing:** In this system of earthing, strip electrodes of cross section not less than 25 mm X 1.6 MM if of copper and 25 mm X 4 mm if of galvanized iron or steel are buried in horizontal trenches of minimum depth 0.5 metre. If round conductors are used, their cross-sectional area shall not be smaller than 3.0 mm<sup>2</sup> if of copper and 6 mm<sup>2</sup> if of galvanized iron or steel. The length of buried conductor shall be sufficient to give the required earth resistance. It shall, however, be not less than 1.5 metres.

This type of earthing is used at places which have rocky soil earth bed because at such places excavation work of plate earthing is difficult.

2. **Rod Earthing:** In this type of earthing, 12.5 mm diameter solid rods of copper or 16 mm diameter solid rods of galvanized iron or steel or hollow section 25 mm GI pipes of length not less than 2.5 metres are driven vertically into the earth either manually or by pneumatic hammer. In order to increase the embedded length of electrodes under the ground, which is sometimes necessary to reduce the earth resistance to desired value, more than one rod sections are hammered one above the other.

This system of earthing is suitable for areas which are sandy in character. This system of earthing is very cheap as no excavation work is involved.

3. **Pipe Earthing:** In the given figure, a GI pipe with a few holes at its lower end is buried to a depth not less than 2 m and atleast 0.6 m away from the foundation of any building. Normally, the size of pipe is either 2m long and 38 mm diameter or 1.37 m long and 51 mm diameter. However, for dry and rocky soil, we use longer pipes. Alternate layers of common salt and charcoal have thickness of 30 mm and 80 mm, respectively.

To maintain good conductivity of the soil, an arrangement is made for pouring water into the earth pit surrounding the earth electrode. This is especially needed during summer. As the pipe has much larger contact area with soil, it can handle larger leakage currents than the plate earthing of same electrode size. The earth wire (made of copper) is tightly fastened to the earth electrode by means of nut and bolt.

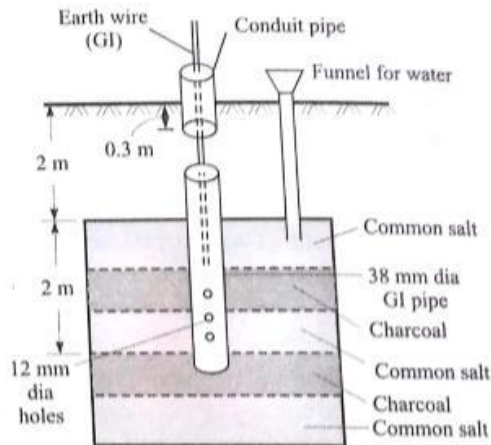

(b) Pipe earthing.

- 4. Plate Earthing:** This is another common system of earthing. In plate earthing an earthing plate either of copper of dimensions 60cm X 60cm X 3mm or of GI of dimensions 60cm X 60cm 6mm is buried into the ground with its face vertical at a depth of not less than 3 metres from ground level. The earth plate is embedded in alternate layers of coke and salt for a minimum thickness of 15cm. The earth wire (GI wire for GI plate earthing and copper wire for copper plate earthing) is securely bolted to an earth plate with the help of a bolt, nut and washer made of material of that of earth plate. A small masonry brick wall enclosure with a cast iron cover on top or an RCC pipe round the earth plate is provided to facilitate its identification and for carrying out periodical inspection and tests. The copper plate and copper wire are usually not employed for grounding because of their higher cost.

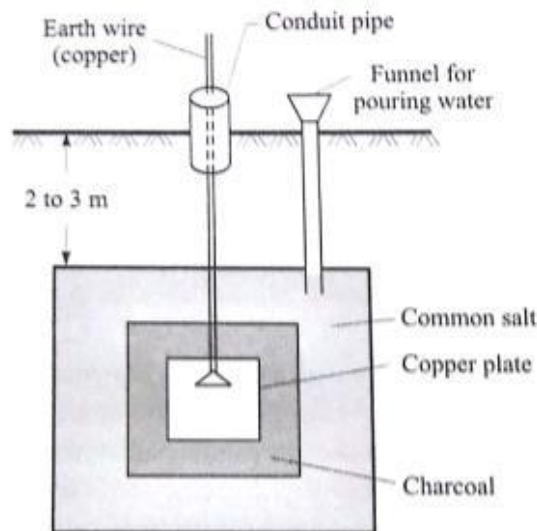

(a) Plate earthing.

**Double Earthing:** For providing better safety, it is advisable to provide two separate earth wires, from two separate earth electrodes, connected to same metallic body of the equipment at two different points. This is known as double earthing. Double earthing is essential, as per Indian Electricity Rule, for metallic bodies of large rating equipment such as transformer, motors etc. working at 400 V and above.

Advantages of Double Earthing:



1. Surety of safety, because if at any time one earthing is ineffective, then another will provide earth path to fault.
2. As the two earth wires are in parallel so the effective resistance from equipment to earth electrode is reduced.

## Types of Batteries, Important characteristics for Batteries:

**Types of Batteries:** There are two types of batteries which are given below:

1. **Primary Battery:** Primary batteries can be used only once because the chemical reactions that supply the current are irreversible. Primary batteries are the most common batteries available today because of their low cost and simplicity in use. Carbon-zinc dry cells and alkaline cells dominate portable consumer battery applications where currents are low and usage is sporadic. Other primary batteries such as those using mercury or lithium-based chemistries, may be used in applications when high energy densities, small sizes, or long shelf life are especially important. In general, primary batteries have dominated two areas: consumer products where the initial cost of the battery is very important and electronic products (such as watches, hearing aids and pacemakers) where drains are low or recharging is not feasible.
  2. **Secondary Battery:** Secondary batteries, sometimes called *storage batteries or accumulators*, can be used, recharged and reused. In these batteries, the chemical reactions that provide current from the battery are readily reserved when current is supplied to the battery. The process of inducing or storing energy in an accumulator is called the charging, and the process of giving out energy in the form of an electric current, the discharging. Accumulators or storage batteries owe their name “secondary” due to the fact that they can supply electrical energy only after they have been charged. Secondary batteries, which are rechargeable, have traditionally been most widely used in industrial and automotive applications. Only two rechargeable battery chemistries, lead acid and nickel-cadmium, have to-date, achieved significant commercial success. There are several types of secondary batteries are given below:
    - **Lead Acid Batteries:** Lead acid batteries, according to service rendered by them, are classified into *automotive, motive power and stationary batteries*.
    - **Nickel-Iron (OR Edison) Batteries:** These batteries are going to become more and more popular as there is a possibility of their development into high energy density batteries for electric vehicles.
    - **Nickel-Cadmium Accumulators:**
    - **Nickel-Metal Hydride Cells:**
1. **Lead Acid Batteries:**

**Charging and Discharging Curves:** Typical charge and discharge curves (variation in terminal voltage) of a lead-acid accumulator are as follows:  
When the cell is charged, the voltage of the Cell increases from 1.8V to 2.2V during first two hours, then increases very slowly, rather remains almost constant for Sufficient time and finally rises to 2.5 to 2.7V.



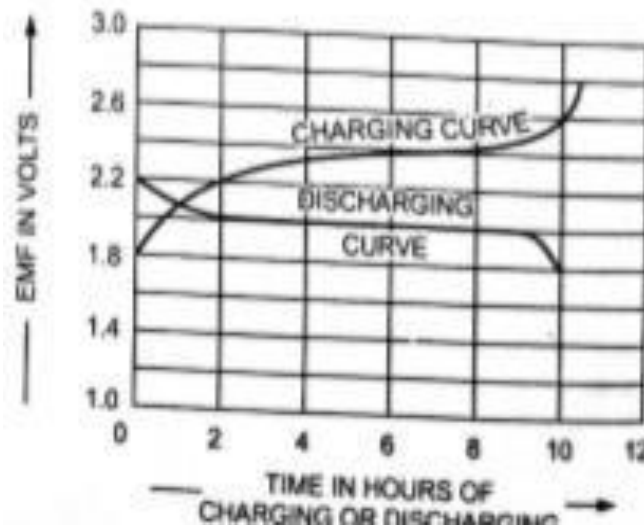

**Caution:** The cell should never be allowed to discharge beyond 1.75V otherwise lead sulphate will be formed on the electrodes which is hard, insoluble and increases the internal resistance of the cell. The conversion of active material into lead sulphate is termed sulphatization.

**2. Nickel-Iron (OR Edison) Batteries:**

**Charge and Discharge Curve:** The given figure shows how the voltage of a nickel-iron cell varies during charging and discharging. The emf, when fully charged, is about 1.4V, decreases to 1.3V rapidly and then slowly to 1.1 or 1.0V of discharge. An average discharge voltage is about 1.2V. The average charging voltage is about 1.7V per cell. The voltage characteristics are similar to those of a lead-acid cell. There is no lower limit to the voltage of the Edison cell because in it there is nothing like sulphation, but discharge is not continued below a useful lower limit. The emf of the cell or battery increases slightly with the temperature. Due to comparatively high internal Resistance, the efficiency of the Edison batteries are lower than those of the lead-acid batteries.

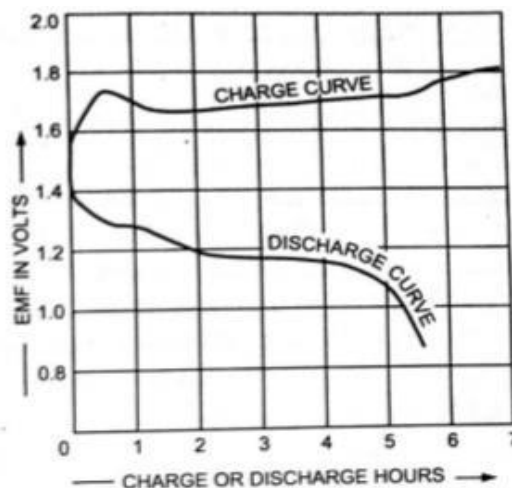

The ampere-hour and watt-hour efficiencies of the Edison batteries are about 80 per cent and 60 per cent respectively. Average energy density is about 50Wh per kg of cell. When assembling batteries for the same voltage, the number of nickel-iron cells required are more than that of lead-acid cells. For example, a 12V lead-acid battery will need  $12/2$  i.e. 6 series-connected cells, whereas the nickel-iron battery will require  $12/1.2$  i.e. 10 series-connected cells to give the same voltage i.e. 12V.



**Application:** These batteries are used for the propulsion of industrial trucks, and mine locomotives and for railway car lighting and air-conditioning because of their rugged construction and other advantages.

## Important characteristics for Batteries:

### Electrical Characteristics:

There are three important characteristics of an accumulator (or storage battery) namely,

- Voltage
- Capacity and
- Efficiency

**1. Voltage:** Average emf of cell is approximately 2.0 volts. The value of emf of a cell does not remain constant but varies with the change in specific gravity of electrolyte, temperature and the length of time since it was last charged. The emf of the cell increases with the increase in specific gravity of the electrolyte and vice versa but increase in specific gravity of the electrolyte also causes increase in internal resistance of the cell, therefore, its value should not go beyond 1.22. Best results are obtained with the electrolyte of specific gravity 1.21.

The emf of the cell, though, not much, but slightly increases with the increase in temperature.

The terminal voltage of battery is higher during charge than that during discharge.

**2. Capacity:** The quantity of electricity which a battery can deliver during single discharge until its terminal voltage falls to 1.8 V/cell is called the capacity of a battery. The capacity of cell is, therefore, expressed in *ampere-hours (A-H)* and is equal to the product of the specific discharge current in amperes multiplied by the number of hours before the cell discharges to the specific extent.

If  $I_d$ =Discharging Current in Ampere and

$T_d$ =Discharging Time of cell or battery in hours

$$\text{Capacity of Battery or Cell} = I_d T_d$$

**3. Efficiency:** The efficiency of the cell can be given in two ways:

**1. The Quantity or Ampere - Hour (A-H) Efficiency:** The ratio of output ampere-hour during discharging to the input ampere-hour during charging of the battery is called **quantity or ampere-hour** efficiency of the battery.

$$\eta_{AH} = \frac{I_d T_d}{I_c T_c}$$

Where  $I_d$ =Discharging Current in Ampere

$I_c$ =Charging Current in Ampere

$T_d$ = Discharging Time of cell or battery in hours

$T_c$ = Charging Time of cell or battery in hours

**2. Energy or Watt - Hour (W-H) Efficiency:** The ratio of output watt-hour during discharging to the input watt-hour during charging of the battery is called **energy or watt-hour** efficiency of the battery.

$$\eta_{WH} = \frac{V_d I_d T_d}{V_c I_c T_c}$$

Where  $V_d$ = Average Terminal Voltage during Discharging

$V_c$ =Average Terminal Voltage during Charging

$I_d$ =Discharging Current in Ampere

$I_c$ =Charging Current in Ampere



$T_d$  = Discharging Time of cell or battery in hours

$T_c$  = Charging Time of cell or battery in hours

### **Elementary calculations for energy consumption and savings:**

Electrical energy is supplied to a consumer by the supplier. To charge the electrical energy consumed by a consumer, an energy meter is installed to its quantity. The reading of the energy meter is taken every month. The difference between the fresh reading and the previous reading tell about the consumption of electrical energy in that month. This quantity of energy is multiplied by the rate (tariff) fixed by the supplier to prepare an electricity bill. However, some other charges such as meter rent, GST, other taxes applicable etc. are also added in the bill.

### **Battery Back-up:**

The time (in hrs) for which a battery can deliver the desired current is called battery back-up of the bank.